

Questions about finding Inductance

These questions touch on many subjects you need to know for quiz 1. They are combinations of things you need to know for questions 2, 3 and 4. You may see some overlap of subjects like these on quiz 1.

Fall 2004

2) Inductance Measurement (19 points)

The RLC circuit below consists of an inductor, a capacitor and a resistor. The input is measured at point A and the output at point B.

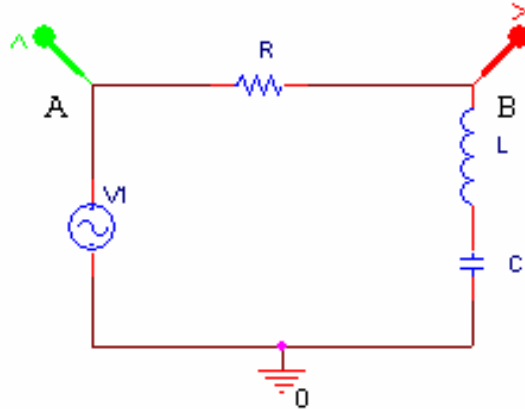

a) Find the transfer function, $H(j\omega)$, at point B. Determine the value of the function, the magnitude and the phase at high and low frequencies.

(2 pts) $H(j\omega) =$

(1 pt) $H_{lo}(j\omega) =$

(1 pt) $H_{hi}(j\omega) =$

(1 pt) $|H_{lo}| =$

(1 pt) $|H_{hi}| =$

(1 pt) $\angle H_{lo} =$

(1 pt) $\angle H_{hi} =$

b) Also calculate the value of $|H(j\omega)|$ at the resonant frequency, ω_0 . (2 points)

$|H_0| =$

c) Calculate the theoretical inductance if your coil has a coin shape. Note this coil has an air core with a diameter of 3 cm. It has 50 turns and is built from 28 gauge wire. The diameter of 28 gauge wire is 0.32 mm and $\mu_0 = 4\pi \times 10^{-7}$ H/m. (3 points)

d) If the measured value of your capacitor is 0.691 μ F and the measured value of your resistor is 1004 ohms, estimate the value of the resonant frequency for this circuit in Hertz. (3 points)

e) Based on your results from the previous parts of this question, sketch the AC sweep of the output of this circuit at point B from very low to very high frequencies. Clearly mark the resonant frequency in Hertz. (3 points)

Fall 2004 Solution

2) Inductance Measurement (19 points)

The RLC circuit below consists of an inductor, a capacitor and a resistor. The input is measured at point A and the output at point B.

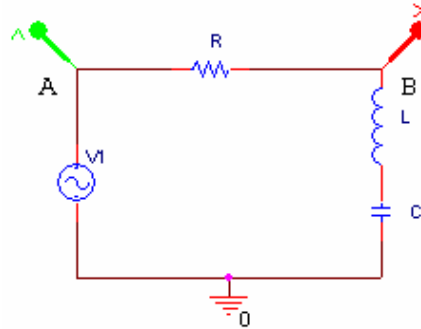

a) Find the transfer function, $H(j\omega)$, at point B. Determine the value of the function, the magnitude and the phase at high and low frequencies.

$$(2 \text{ pts}) H(j\omega) = \frac{[(1/j\omega LC) + j\omega L] / [R + (1/j\omega LC) + j\omega L]}{[1 - \omega^2 LC] / [j\omega RC + 1 - \omega^2 LC]}$$

$$(1 \text{ pt}) H_{lo}(j\omega) = 1$$

$$(1 \text{ pt}) H_{hi}(j\omega) = -\omega^2 LC / -\omega^2 LC = 1$$

$$(1 \text{ pt}) |H_{lo}| = 1$$

$$(1 \text{ pt}) |H_{hi}| = 1$$

$$(1 \text{ pt}) \angle H_{lo} = 0 \text{ rad}$$

$$(1 \text{ pt}) \angle H_{hi} = 0 \text{ rad}$$

b) Also calculate the value of $|H(j\omega)|$ at the resonant frequency, ω_0 . (2 points)

$$H_0 = \frac{[1 - (1/\sqrt{LC})^2 LC] / [j(1/\sqrt{LC}) RC + 1 - (1/\sqrt{LC})^2 LC]}{[0] / [j(RC / (\sqrt{LC}))]} = 0$$

$$|H_0| = 0$$

c) Calculate the theoretical inductance if your coil has a coin shape. Note this coil has an air core with a diameter of 3 cm. It has 50 turns and is built from 28 gauge wire. The diameter of 28 gauge wire is 0.32 mm and $\mu_0 = 4\pi \times 10^{-7}$ H/m. (3 points)

$$L = \mu_0 N^2 r_c [\ln(8r_c/r_w) - 2] \quad r_c = 1.5 \text{ cm} = 0.015 \text{ meters} \quad r_w = .16 \text{ mm} = 0.00016 \text{ meters}$$

$$L = (4\pi)(50)^2 (.015) [\ln(8(.015)/(.00016)) - 2] \times 10^{-7} = 2.18 \times 10^3 \times 10^{-7}$$

$$L = 2.18 \times 10^{-4} \text{ H} = 0.218 \text{ mH}$$

d) If the measured value of your capacitor is $0.691 \mu\text{F}$ and the measured value of your resistor is 1004 ohms , estimate the value of the resonant frequency for this circuit in Hertz. (3 points)

$$f_0 = 1/(2\pi\sqrt{LC}) = 1/(2\pi\sqrt{0.218\text{m} \cdot 691\mu}) = 12.967\text{K Hz} \approx 13\text{K Hz}$$

e) Based on your results from the previous parts of this question, sketch $|H|$ of this circuit at point B from very low to very high frequencies. Clearly mark the resonant frequency in Hertz. (3 points)

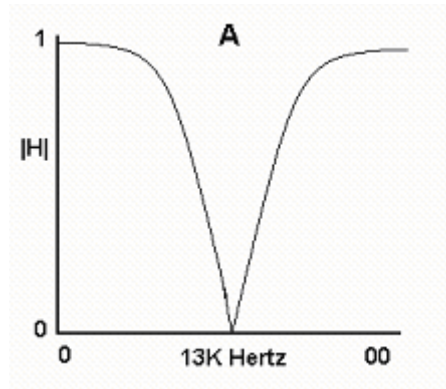

Spring 2004 Note: OP-AMPS (TRIANGLE SHAPED COMPONENT) WILL BE COVERED ON THE NEXT EXAM, HOWEVER THE CONTENT HERE (ASIDE FROM THE ACTUAL CIRCUIT) IS RELEVANT TO QUIZ 1.

1. Inductance/Transformers (25 points)

In a variation of the inductance measurement experiment we did recently, a student decides to combine the configuration with an op-amp to see if things work better. The following circuit is built:

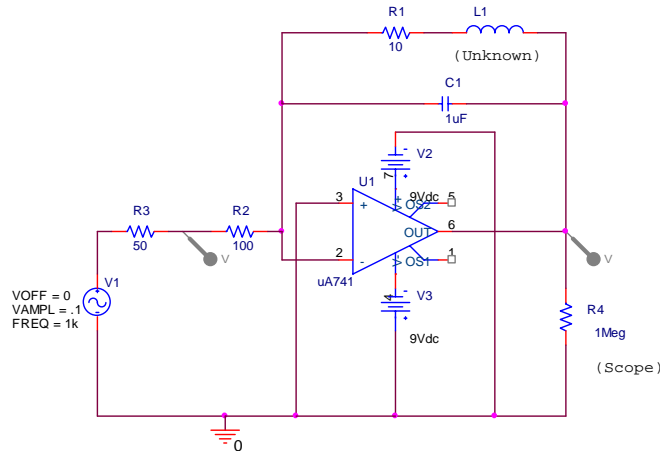

a. Capacitor C1 is varied until a distinctive response is obtained that can be used to find the unknown inductance. The four values of capacitance tried were 1uF, .1uF, .01uF, .001uF, producing the four plots that follow. Identify the value of capacitance used for each plot. (1 point each) and find the unknown inductance for each plot. (2 points each) Note: The bump on some of the plots is caused by the unusual decision to use an op amp in the circuit. The resonant frequency is at the leftmost bump on all plots. [Total=12 points]

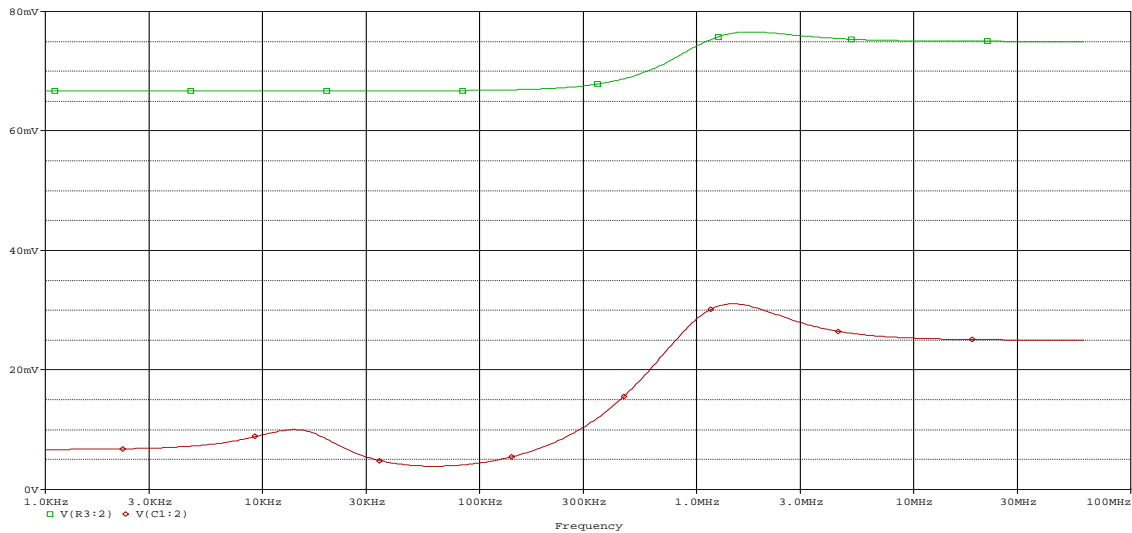

Capacitance:

Inductance:

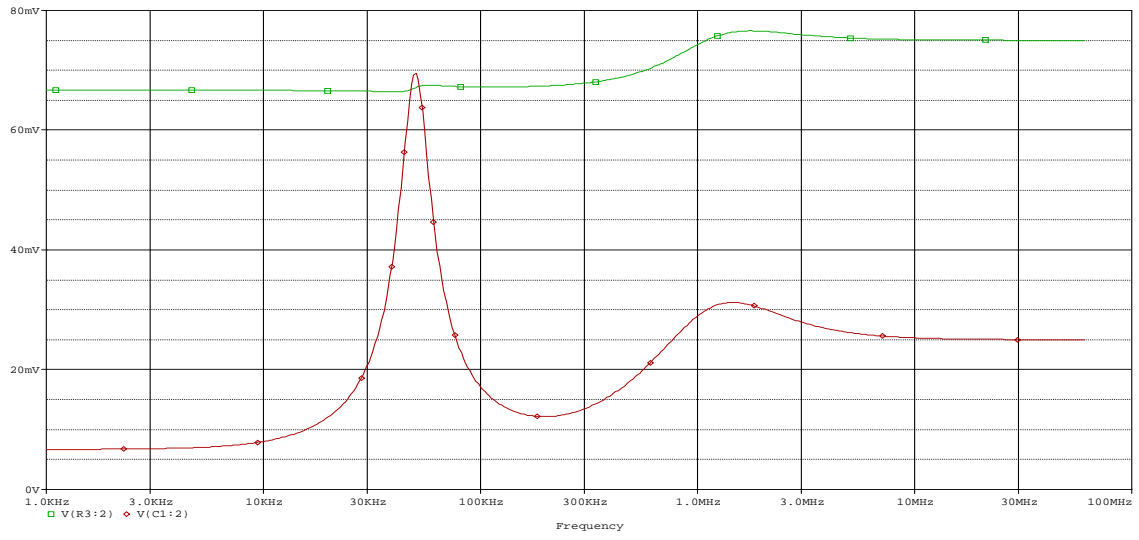

Capacitance:

Inductance:

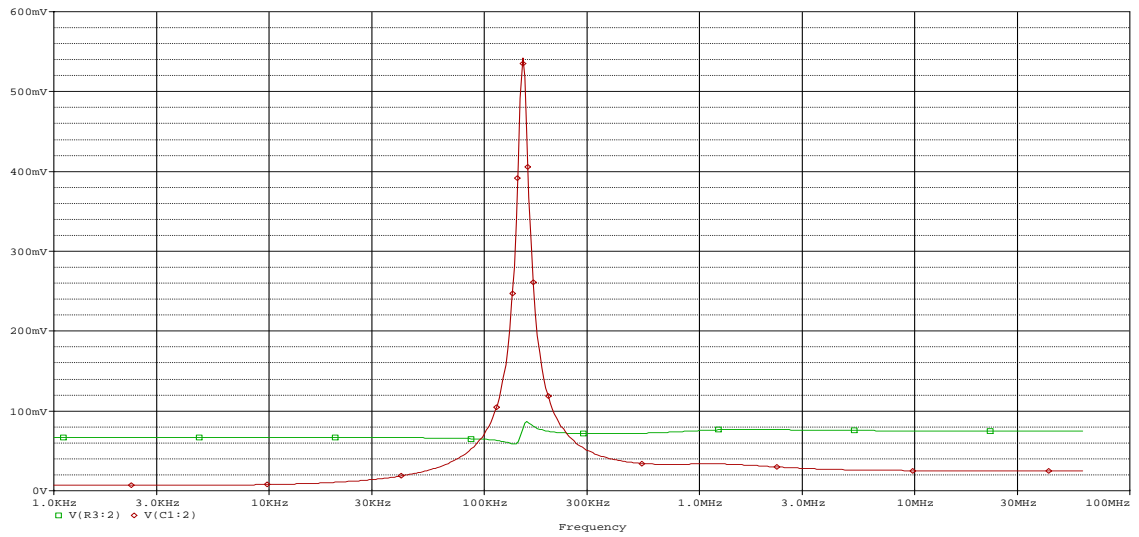

Capacitance:

Inductance:

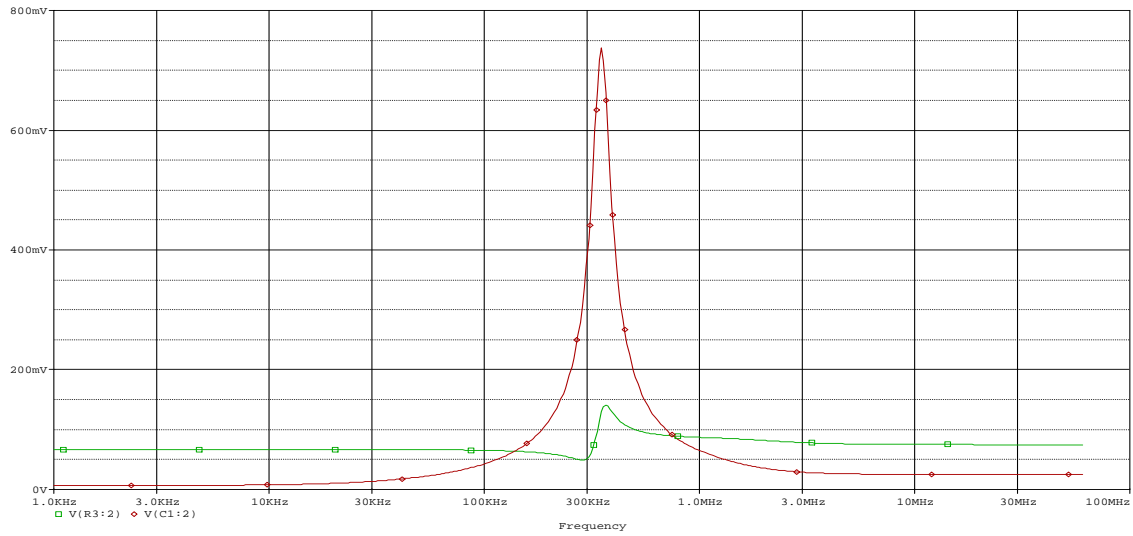

Capacitance:

Inductance:

b. The resistance shown in series with the inductor is the resistance of the inductor coil. Assuming the student works in our classroom, how would he or she have measured this resistance? (3 points)

c. If the particular application where the inductor is to be used requires a smaller resistance, a new inductor would have to be found or made. If you were to make an inductor with nearly identical inductance, but with much less resistance, how would you do it? Explain your reasoning. (3 points)

Spring 2004 solution Note: OP-AMPS (TRIANGLE SHAPED COMPONENT) WILL BE COVERED ON THE NEXT EXAM, HOWEVER THE CONTENT HERE (ASIDE FROM THE ACTUAL CIRCUIT) IS RELEVANT TO QUIZ 1.

1. Inductance/Transformers (25 points)

In a variation of the inductance measurement experiment we did recently, a student decides to combine the configuration with an op-amp to see if things work better. The following circuit is built:

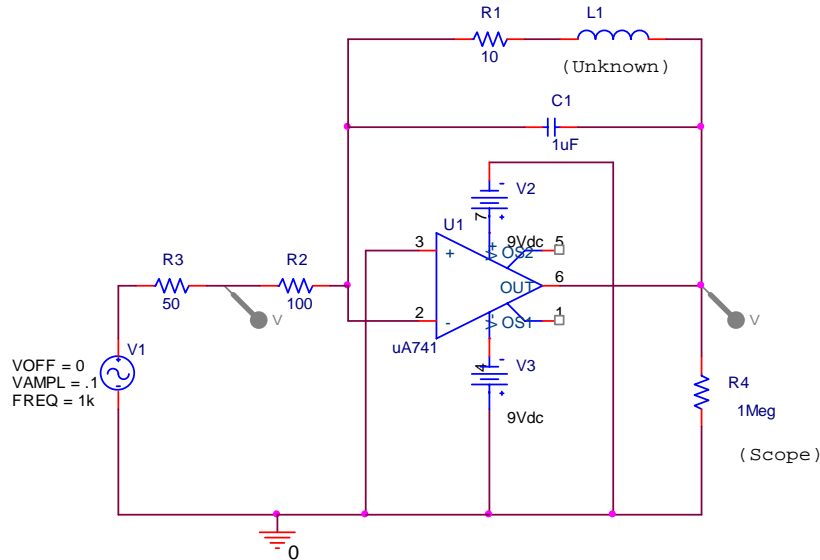

(Part a for Test A)

a. Capacitor C1 is varied until a distinctive response is obtained that can be used to find the unknown inductance. The four values of capacitance tried were 1uF, .1uF, .01uF, and .001uF, producing the four plots that follow. Identify the value of capacitance used for each plot. (1 point each) and find the unknown inductance for each plot. (2 points each) Note: The bump on some of the plots is caused by the unusual decision to use an op amp in the circuit. The resonant frequency is at the leftmost bump on all plots. [Total=12 points]

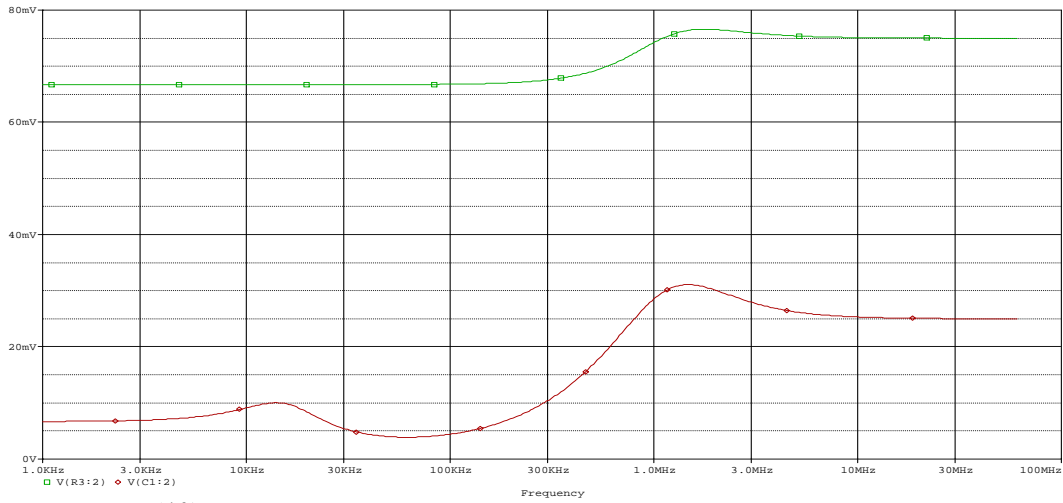

$$f_0 = 10^{(4.2)} = 15849 \text{ Hz} \quad \omega_0 = 2\pi f_0 = 99582 \text{ rad/sec}$$

Capacitance: **1 μ F** (lowest resonant frequency means highest capacitance)

Inductance: $L = 1/[(\omega_0^2)(C)] = 1/9916.5$ **L=0.1 mH** (for all cases)

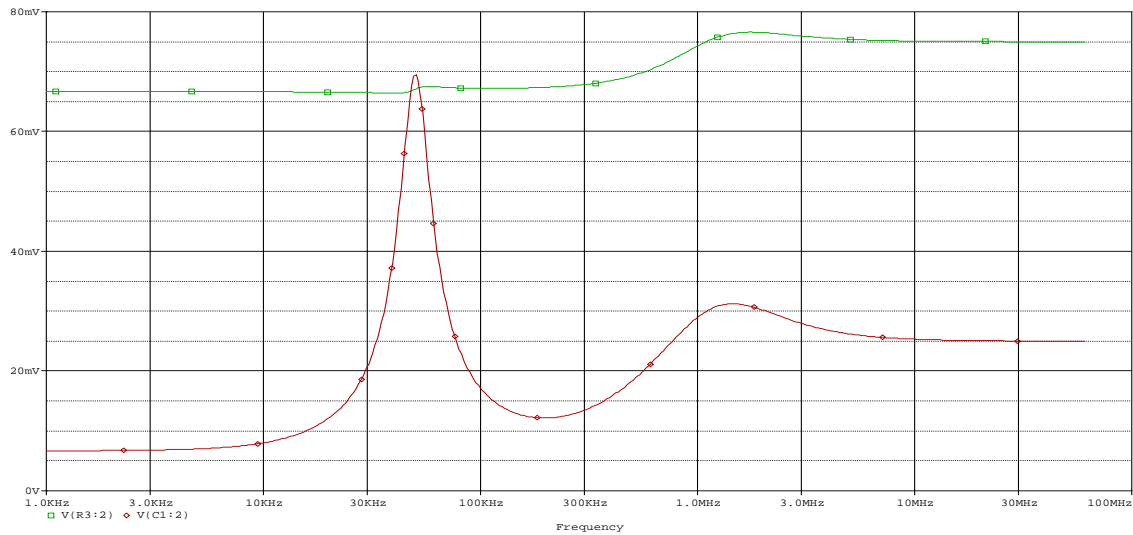

$$f_0 = 10^{(4.7)} = 50119 \text{ Hz} \quad \omega_0 = 2\pi f_0 = 314905 \text{ rad/sec}$$

Capacitance: **0.1 μ F**

Inductance: $L = 1/[(\omega_0^2)(C)] = 1/9916.5$ **L=0.1 mH** (for all cases)

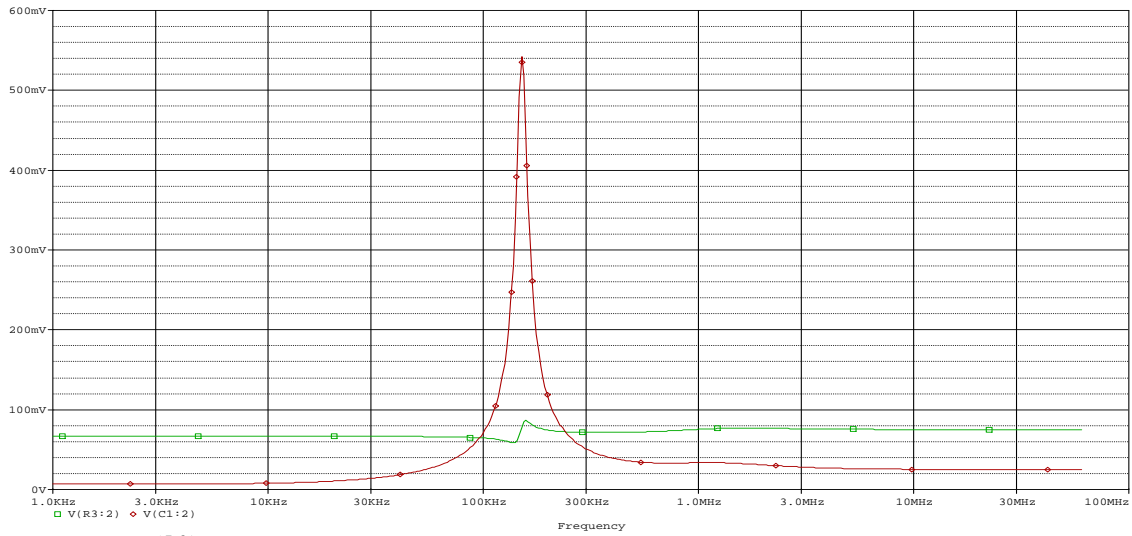

$$f_0 = 10^{(5.2)} = 158490 \text{ Hz} \quad \omega_0 = 2\pi f_0 = 995817 \text{ rad/sec}$$

Capacitance: **0.01uF**

Inductance: $L = 1/[(\omega_0^2)(C)] = 1/9916.5$ **L=0.1 mH (for all cases)**

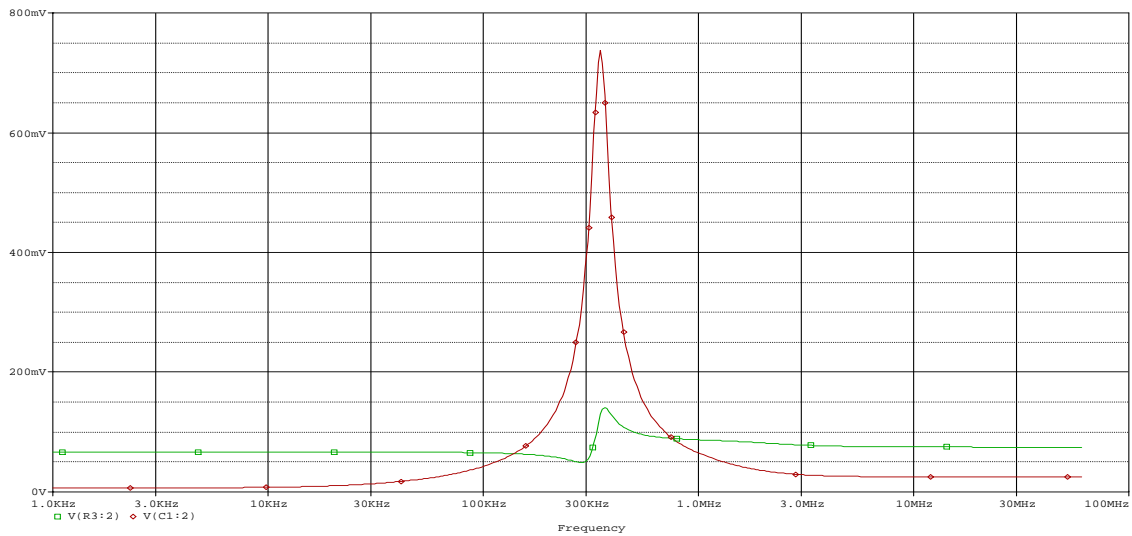

$$f_0 = 10^{(5.7)} = 501187 \text{ Hz} \quad \omega_0 = 2\pi f_0 = 3149052 \text{ rad/sec}$$

Capacitance: **0.001uF** (highest resonant frequency means lowest capacitance)

Inductance: $L = 1/[(\omega_0^2)(C)] = 1/9916.5$ **L=0.1 mH (for all cases)**

I interpreted these a bit creatively to get them to come out perfectly. If yours are within an order of magnitude, the answers are good. Remember that the inductance changes at different frequencies (especially high frequencies).

b. The resistance shown in series with the inductor is the resistance of the inductor coil. Assuming the student works in our classroom, how would he or she have measured this resistance? (3 points)

- 1) Turn on the digital multimeter
- 2) Plug a dual banana connector between low and high for resistance
- 3) Connect a BNC cable to the dual banana connector
- 4) Connect a mini-grabber to the BNC cable
- 5) Connect the red and black leads of the mini-grabber cable together to measure the resistance of the wires. (Let this be R_w).
- 6) Disconnect the two leads and connect one lead to each end of the inductor.
- 7) Measure the resistance of the inductor and cable. (Let this be R_{w+L} .)
- 8) Subtract the wire resistance from the measured resistance to get the resistance of the inductor itself, R_L . ($R_L = R_{w+L} - R_w$)

(Answers may vary)

c. If the particular application where the inductor is to be used requires a smaller resistance, a new inductor would have to be found or made. If you were to make an inductor with nearly identical inductance, but with much less resistance, how would you do it? Explain your reasoning. (3 points)

The equation for inductance is $L = \frac{\mu N^2 \pi r_c^2}{d}$, where μ is a constant, N is the number of turns, r_c is the coil radius and d is the coil diameter. My resistance equation tells me that $R = \frac{l}{\sigma A} = \frac{l}{\sigma(\pi r_w^2)}$, where σ is a constant, and r_w is the radius of the wire. Since the inductance does not depend upon the radius of the wire itself and increasing this radius decreases the resistance, I could easily create another coil of similar inductance and less resistance by winding a thicker wire (with greater radius and lower resistance) of the same material around the same core with the same length and the same number of turns.

Fall 2003

Question 2 – Measuring Inductance (20 points)

Given the following circuit and its AC sweep below:

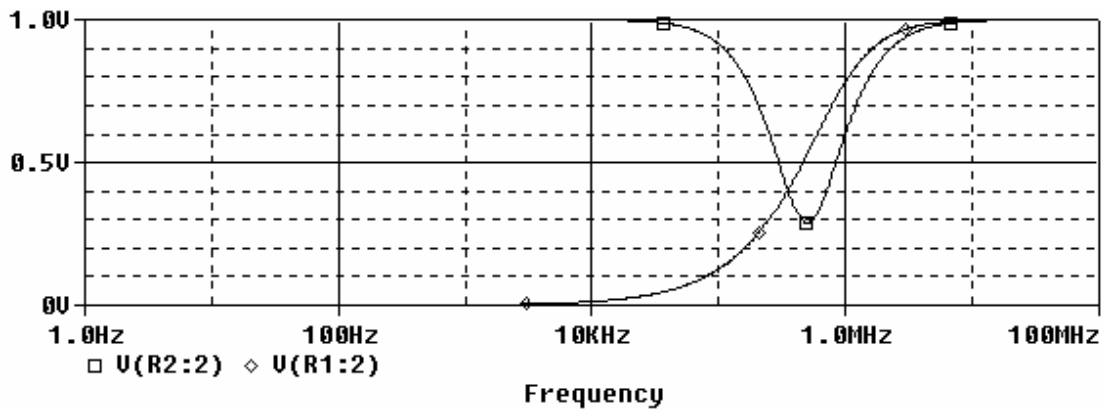
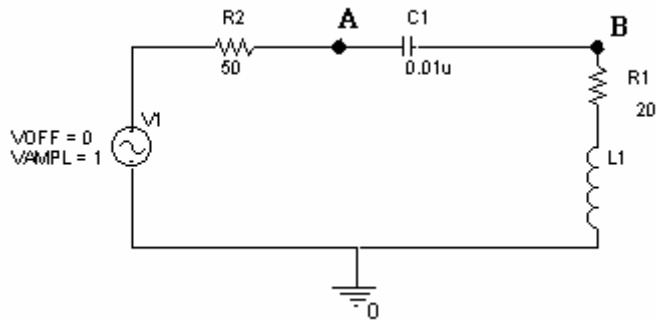

a) Find the transfer function, $H(j\omega)$, at point B. Determine the function and the magnitude and the phase at high and low frequencies. (8 points)

(2 pts) $H(j\omega) =$

(1 pt) $H_{lo}(j\omega) =$

(1 pt) $H_{hi}(j\omega) =$

(1 pt) $|H_{lo}| =$

(1 pt) $|H_{hi}| =$

(1 pt) $\angle H_{lo} =$

(1 pt) $\angle H_{hi} =$

b) Based on your results from part a), indicate on the plot the trace for the magnitude of the voltage at point B (2 points).

c) Find the resonant frequency f_0 from the plot. Notice that the x-axis has logarithmic scale. (ie. $10^{0.5} = 3.16$) (3 points)

d) Solve for the unknown inductance. (5 points)

e) Both of the resistances in this circuit are not physical resistors. They represent the resistance of something else in the circuit. Assuming that these do not represent wire resistance, what do they represent? (2 points)

Fall 2003 Solution

Question 2 – Measuring Inductance (20 points)

Given the following circuit and its AC sweep below:

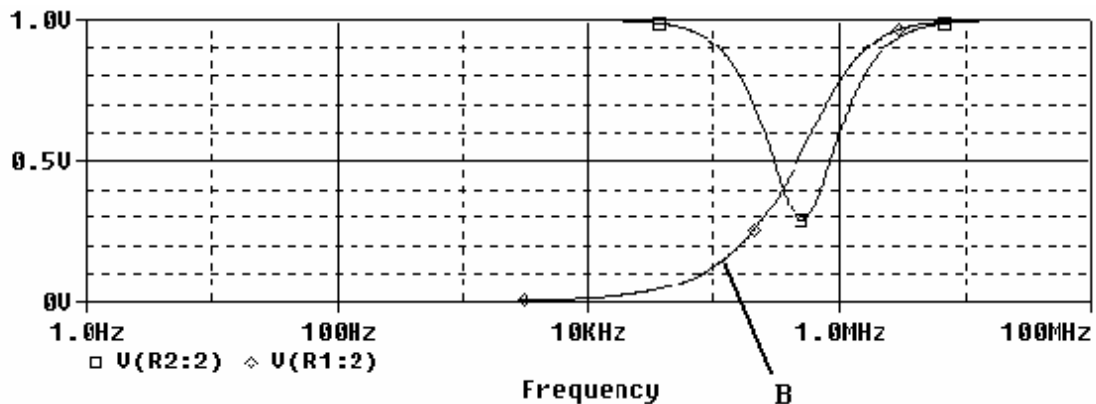
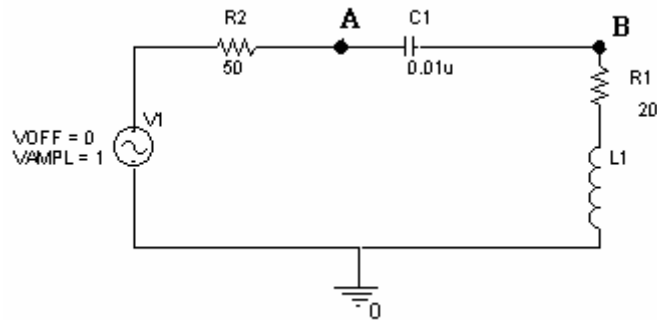

a) Find the transfer function, $H(j\omega)$, at point B. Determine the function and the magnitude and the phase at high and low frequencies. (8 points)

(2 pts) $H(j\omega) =$

method 1: excluding R2

$$H(j\omega) = \frac{R1 + j\omega L1}{R1 + j\omega L1 + 1/j\omega C1}$$

$$H(j\omega) = \frac{j\omega R1 C1 - \omega^2 L1 C1}{j\omega R1 C1 - \omega^2 L1 C1 + 1}$$

method 2: including R2

$$H(j\omega) = \frac{R1 + j\omega L1}{R2 + R1 + j\omega L1 + 1/j\omega C1}$$

$$H(j\omega) = \frac{j\omega R1 C1 - \omega^2 L1 C1}{j\omega (R1 + R2) C1 - \omega^2 L1 C1 + 1}$$

either is ok

(1 pt) $H_{lo}(j\omega) = j\omega R1 C1$

(1 pt) $H_{hi}(j\omega) = 1$

(1 pt) $|H_{lo}| = 0$

(1 pt) $|H_{hi}| = 1$

(1 pt) $\angle H_{lo} = \pi/2$

(1 pt) $\angle H_{hi} = 0$

b) Based on your results from part a), indicate on the plot the trace for the magnitude of the voltage at point B (2 points).

c) Find the resonant frequency f_0 from the plot. Notice that the x-axis has logarithmic scale. (ie. $10^{0.5} = 3.16$) (3 points)

$$f_0 = 10 \text{EE}(5.7) = 501,187 \quad f_0 = 500 \text{K Hz} \quad (\text{answers may vary})$$

d) Solve for the unknown inductance. (5 points)

$$f_0 = 1/[2\pi \text{sqrt}(L1C1)] \quad L1 = 1/[C1(2\pi f_0)^2]$$
$$L1 = 1/(0.01 \text{EE}-6)(\pi \text{EE}+6)^2 = 1/[0.0987 \text{EE}+6] = 10.1 \text{EE}-6$$
$$L1 = 10 \text{ uF} \quad (\text{answers may vary})$$

e) Both of the resistances in this circuit are not physical resistors. They represent the resistance of something else in the circuit. Assuming that these do not represent wire resistance, what do they represent? (2 points)

The resistor R2 is the 50 ohm impedance of the function generator.
The resistor R1 is the resistance in the wire of the inductor, L1.

Spring 2003

2) Inductance Calculation and Measurement (30 points)

You have found an inductor and wish to determine its inductance. Here is a picture:



You find that it has a wire gauge diameter of 0.51 mm (24 gauge), a length of 14.5 mm, a core diameter of 5.0 mm and 27 turns. You assume that it has an air core ($\mu = 1.257 \times 10^{-6}$ Henries/meter).

a) Calculate the theoretical inductance of the inductor. (5 pts)

b) You wish to verify that the core is indeed air, so you place the inductor into the circuit you used in experiment 9.

[Note: $R_1 = 50$ ohms, $R_2 = 50$ ohms, $C_1 = 0.68\mu\text{F}$, and L_1 is your inductor.]

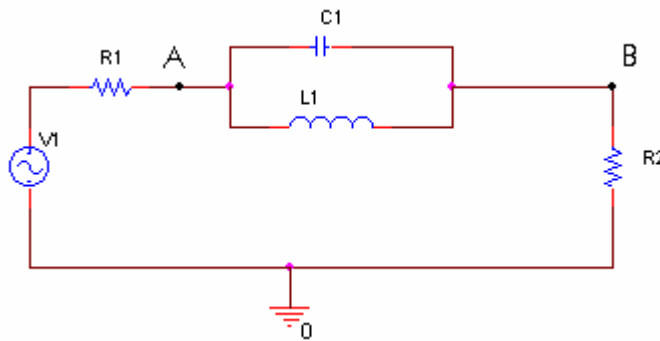

You generate the three plots on the following page.

i) Label the three circuits. Which one is at the resonance frequency? below the resonance frequency? above the resonance frequency? (6 pts)

ii) Label the input (point A) and the output (point B) on the plot at resonance on the following page. (4 pts)

Show work here:

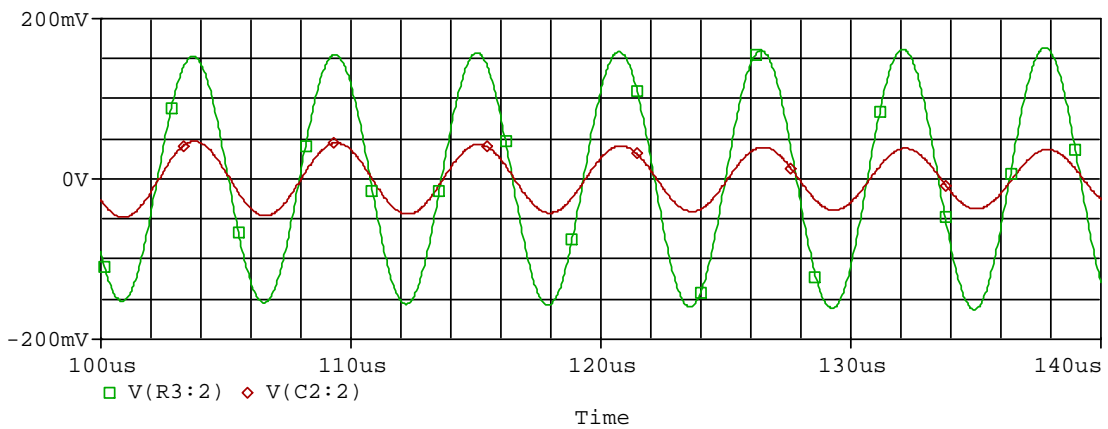
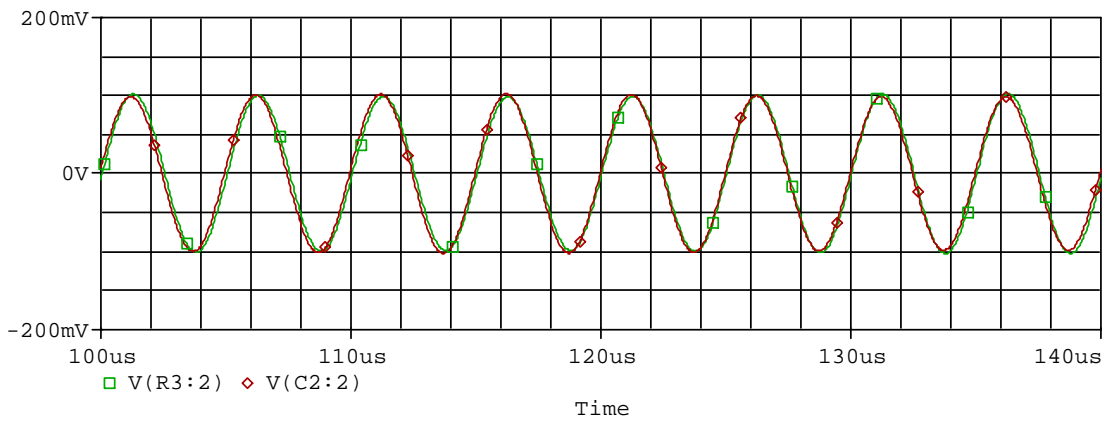
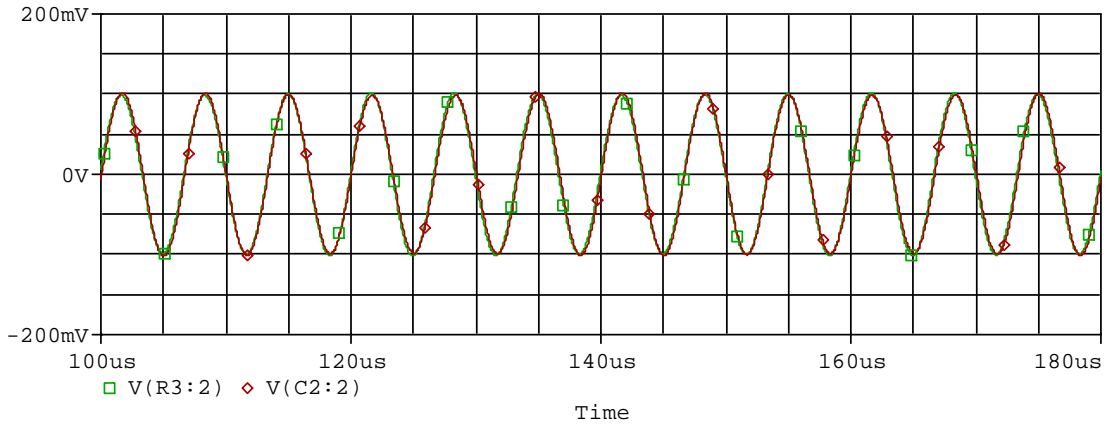

iii) Given the above plots, calculate the resonance frequency, ω_0 , of your circuit.(3 pts)

iv) According to the frequency in iii), what is your inductance? (3 pts)

iv) Given your calculations in part a), calculate the theoretical resonance frequency, ω_0 , of your circuit. (3 pts)

c) Does the inductance equation overestimate or underestimate inductance? Is your guess that the core is probably made of air correct? Why or why not? (6 pts)

Spring 2003 solution

2) Inductance Calculation and Measurement (30 points)

You have found an inductor and wish to determine its inductance. Here is a picture:



You find that it has a wire gauge diameter of 0.51 mm (24 gauge), a length of 14.5 mm, a core diameter of 5.0 mm and 27 turns. You assume that it has an air core ($\mu = 1.257 \times 10^{-6}$ Henries/meter).

a) Calculate the theoretical inductance of the inductor. (5 pts)

$$L = [\mu N^2 \pi r^2 / d] \quad d = 14.5 \times 10^{-3} \text{ m} \quad r = 2.5 \times 10^{-3} \text{ m}$$

$$L = [1.257 \times 10^{-6} \times 729 \times \pi \times 6.25 \times 10^{-6}] / (14.5 \times 10^{-3}) = 1.24 \times 10^{-6} \text{ H}$$

$$L = 1.24 \mu\text{H}$$

b) You wish to verify that the core is indeed air, so you place the inductor into the circuit you used in experiment 9.

[Note: $R_1 = 50$ ohms, $R_2 = 50$ ohms, $C_1 = 0.68 \mu\text{F}$, and L_1 is your inductor.]

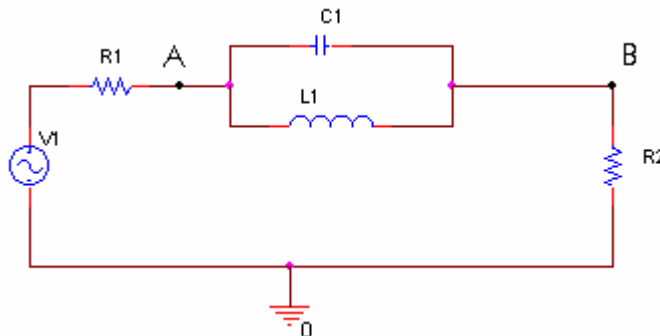

You generate the three plots on the following page.

i) Label the three circuits. Which one is at the resonance frequency? below the resonance frequency? above the resonance frequency? (6 pts)

ii) Label the input (point A) and the output (point B) on the plot at resonance on the following page. (4 pts)

Show work here:

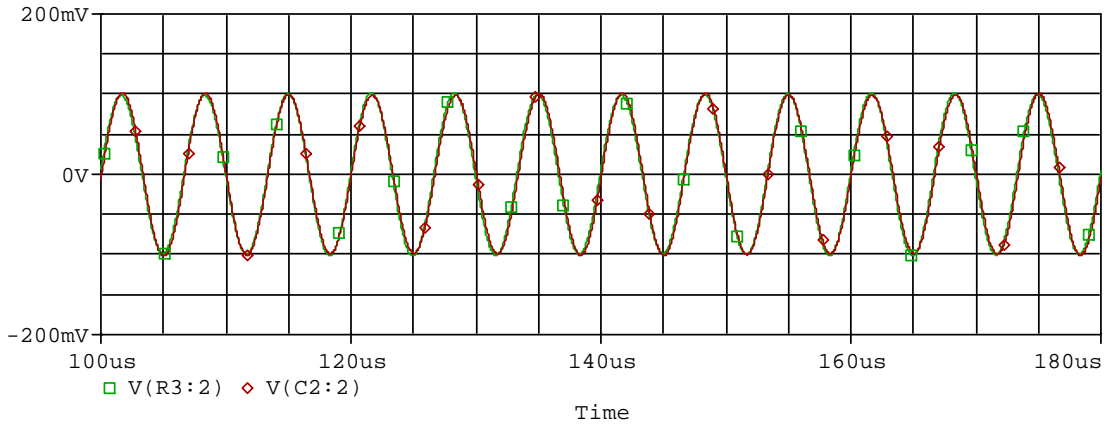

$$f = 12 \text{ cycles} / 80 \mu\text{s} = 0.15 \text{ Meg Hz} = 1500 \text{ K Hz} \quad \text{BELOW RESONANCE}$$

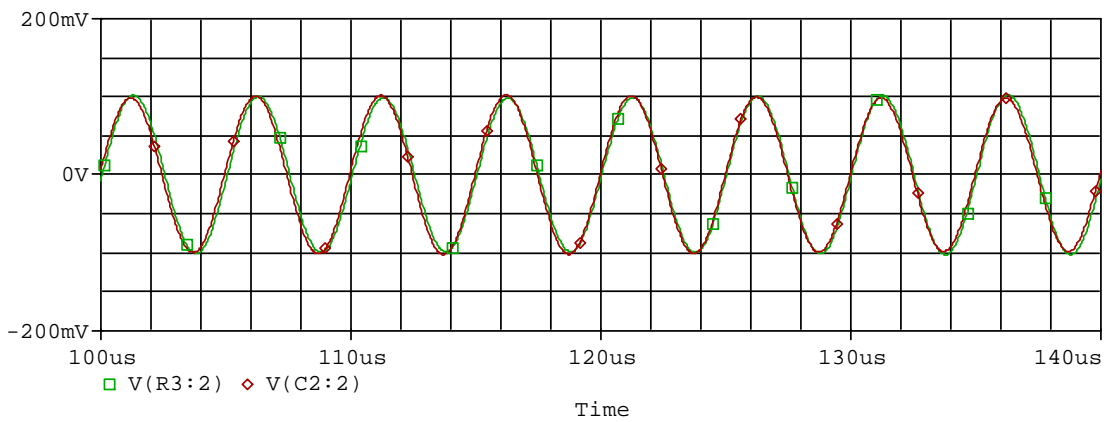

$$f = 8 \text{ cycles} / 40 \mu\text{s} = 0.2 \text{ Meg Hz} = 2000 \text{ K Hz} \quad \text{ABOVE RESONANCE}$$

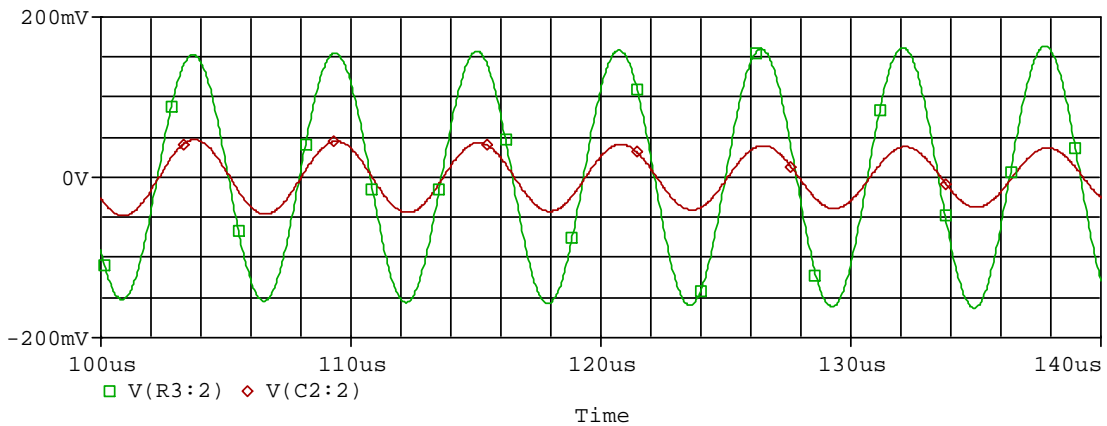

$$f = 5 \text{ cycles} / (136.3 - 108) \mu\text{s} = .1767 \text{ Meg Hz} = 1767 \text{ K Hz} \quad \text{AT RESONANCE}$$

iii) Given the above plots, calculate the resonance frequency, ω_0 , of your circuit. (3 pts)

$$\omega_0 = 2\pi f_0 = 2 \times \pi \times 1767 \text{ K} = 1110.1 \text{ K rad/sec} \quad \omega_0 = 1.11 \text{ Meg rad/sec}$$

iv) According to the frequency in iii), what is your inductance? (3 pts)

$$\omega = 1/\sqrt{LC} \quad L = 1/C(\omega)^2 = 1/(1110K)^2(0.68 \times 10^{-6}) = 1.193 \times 10^{-6} H$$

$$L = 1.193 \mu H$$

iv) Given your calculations in part a), calculate the theoretical resonance frequency, ω , of your circuit. (3 pts)

$$\omega = 1/\sqrt{LC} \quad \omega = 1/\sqrt{(1.24 \times 10^{-6}) \times (0.68 \times 10^{-6})} \quad \omega = 1.089 \text{ Meg rad/sec}$$

c) Does the inductance equation overestimate or underestimate inductance? Is your guess that the core is probably made of air correct? Why or why not? (6 pts)

The equation should overestimate the inductance, as stated in experiment 9. From the two inductances we found here, we have verified that this is true. $1.24 \mu H > 1.19 \mu H$

The values $1.24 \mu H$ and $1.19 \mu H$ are not exactly alike, but they are very close. The core must be air. If we had used something besides air (like iron, for example) they would be different by several orders of magnitude.

Fall 2002

2. Inductance Measurement (20 points)

In the circuit below, $V_{in} = 200\text{mV}$, $R1 = 300\Omega$, $C1 = 0.05\mu\text{F}$ and $L1$ is unknown.

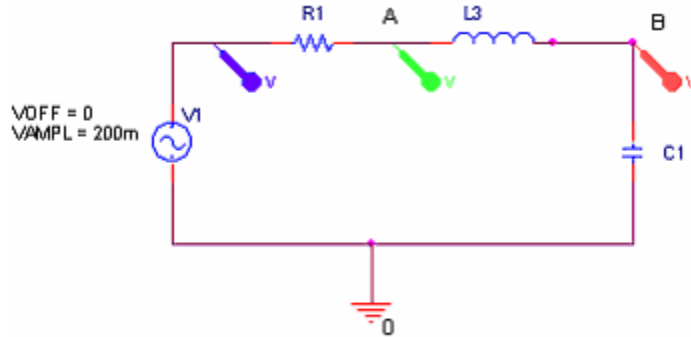

- a) If you perform AC Sweep of the voltages at points A and B, illustrate both traces in the space below where the resonance frequency f_0 is 40 kHz (please label the traces A and B, respectively). 6 points

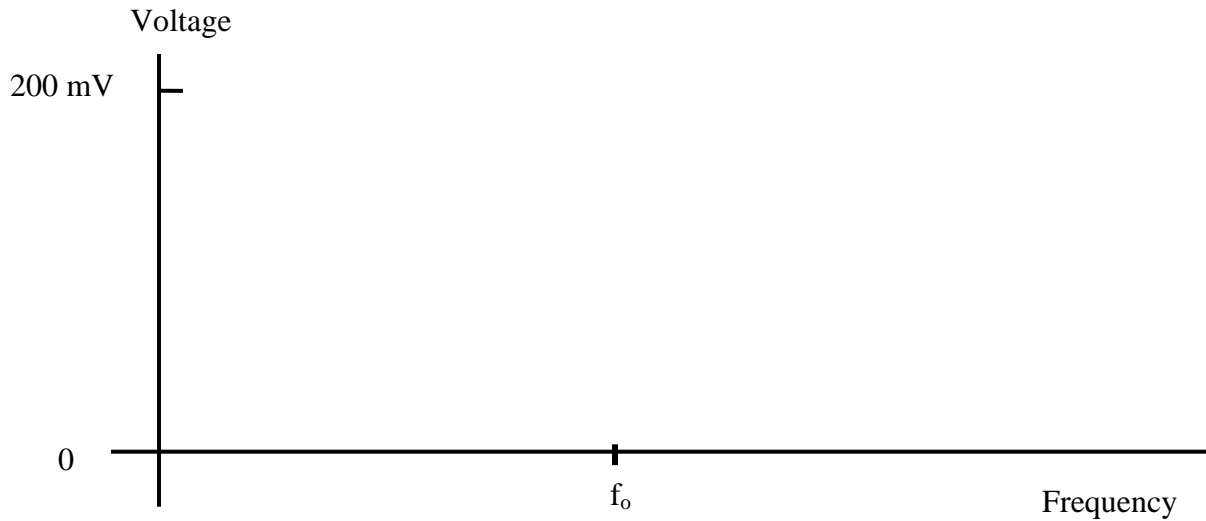

- b) Explain why the two traces behave at very low and very high frequencies the way you illustrated above, respectively. You can explain in details using either transfer function of the circuit or open/short approximation for capacitor and inductance. (6 points)

c) Solve for the unknown inductance from information obtained from the figure above. (6 points)

d) Discuss how the figure would be different if the locations of the capacitor and inductor in the circuit are switched. (2 points)

Fall 2002 Solution

(none available)

Spring 2002

2) Inductance Measurement (20 points)

In the circuit below, $V_{in} = 200\text{mV}$, $R_2 = 300\Omega$, $C_1 = 0.05\mu\text{F}$ and L_1 is unknown.

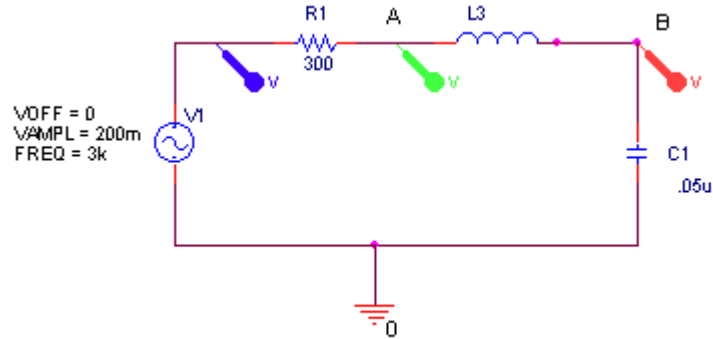

Plot I: Displays an AC sweep of the voltage at points A and B.

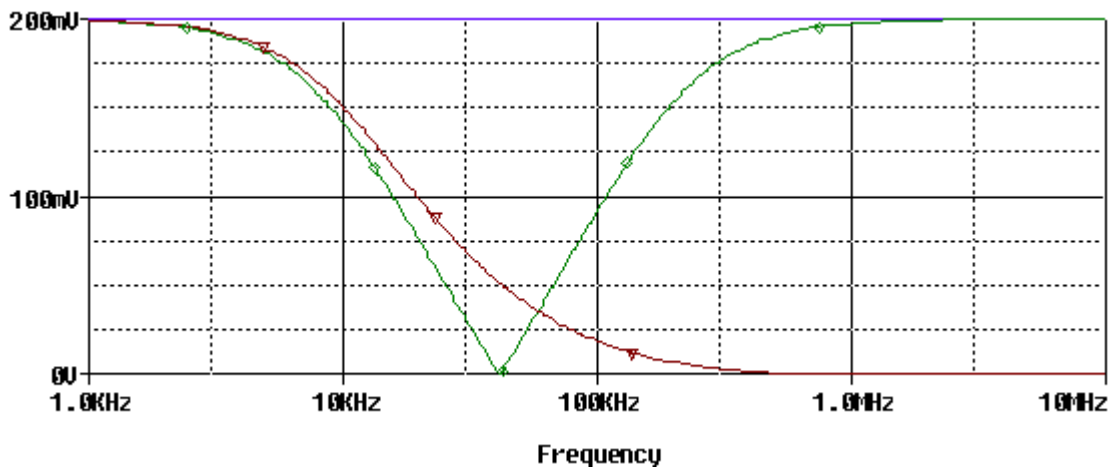

Plot II: Displays an AC sweep of the phase at points A and B.

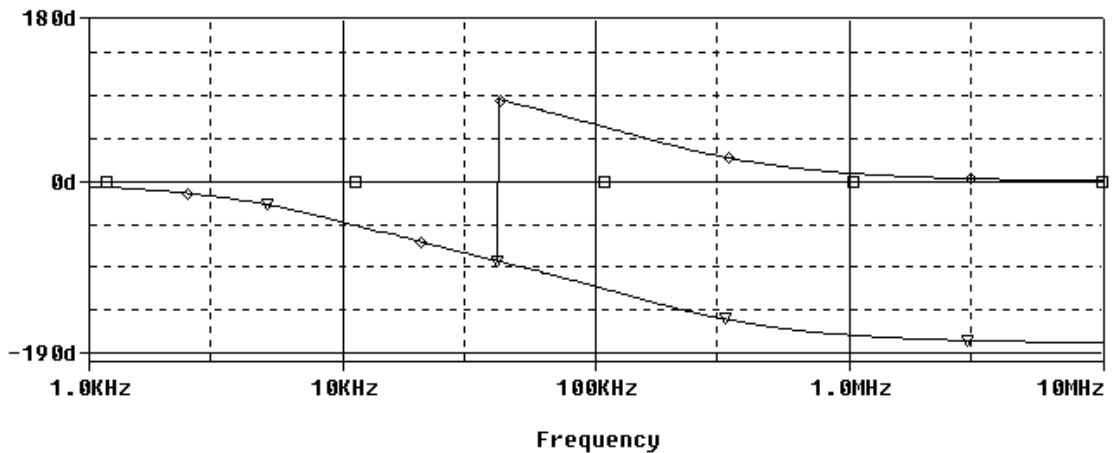

a) Find the transfer function, $H(j\omega)$, at point B. Determine the value of the function, the magnitude and the phase at hi and low frequencies.

(2 pts) $H(j\omega) =$

(1 pt) $H_{lo}(j\omega) =$

(1 pt) $H_{hi}(j\omega) =$

(1 pt) $|H_{lo}| =$

(1 pt) $|H_{hi}| =$

(1 pt) $\angle H_{lo} =$

(1 pt) $\angle H_{hi} =$

b) Based on your results from part a), indicate on plot I the trace for the magnitude of the voltage at point B (2 pts).

c) Based on your results from part a), indicate on plot II the trace for the phase at point B (2 pts).

d) Find the resonance frequency f_0 from the plot. Notice that the x-axis has logarithmic scale. (ie. $10^{0.5} = 3.16$) (2 pts)

e) Solve for the unknown inductance. (6 pts)

Spring 2002 solution

2) Inductance Measurement (20 points)

a) Find the transfer function, $H(j\omega)$, at point B. Determine the value of the function, the magnitude and the phase at hi and low frequencies.

$$(2 \text{ pts}) H(j\omega) = [1/j\omega C1] / [R1 + j\omega L3 + 1/j\omega C1]$$
$$H(j\omega) = 1 / [j\omega R1 C1 + 1 - \omega^2 L3 C1]$$

$$(1 \text{ pt}) H_{lo}(j\omega) = 1$$

$$(1 \text{ pt}) H_{hi}(j\omega) = -1/\omega^2 L3 C1$$

$$(1 \text{ pt}) |H_{lo}| = 1$$

$$(1 \text{ pt}) |H_{hi}| = 0$$

$$(1 \text{ pt}) \angle H_{lo} = 0$$

(positive real)

$$(1 \text{ pt}) \angle H_{hi} = \pi \text{ (negative real)}$$

b) Based on your results from part a), indicate on plot I the trace for the magnitude of the voltage at point B (2 pts).

The trace should be high at low frequencies and 0 at high frequencies.

The red upside down triangle trace from +200mV at 1KHz to 0 at 10MHz

c) Based on your results from part a), indicate on plot II the trace for the phase at point B (2 pts).

The trace should be 0 at low frequencies and 180 (or -180) at high frequencies.

The upside down triangle trace from 0d at 1KHz to -180d at 10MHz.

d) Find the resonance frequency f_0 from the plot. Notice that the x-axis has logarithmic scale. (ie. $10^{0.5} = 3.16$) (2 pts)

Look at the place on plot I where the resonance goes to zero.

Note: 10KHz = 10×10^4 and 100KHz = 10×10^5

(Note: the middle (dotted) line is at about 3.16×10^4 Hz)

The resonance is about 60% between 10×10^4 and 10×10^5

This means the resonance is at $10^{(0.60)} \times 10^4$ or at 3.98×10^4 Hz

$f_0 = 40\text{KHz}$ (Note that I rounded here because my ability to read the graph is limited and so I figure it is about here.)

e) Solve for the unknown inductance. (6 pts)

$$\omega_0 = 2\pi f_0 = 1/\text{sqrt}(L3C1) \rightarrow L3 = 1/[C1*(2\pi f_0)^2]$$

$$0.5\mu*[2(3.14)(40K)]^2 = 1/L3$$

$$L3 = 32\mu \text{ Henries}$$

Fall 2001 Solution

EI TEST 3A Fall 2001

Name _____ Sect _____

Please show all work on all questions for full credit, some explanation of your answer is required.

2. Inductance Measurement (20 points)

In the circuit below, $V_{in} = 1\text{V}$, $R_s = 50\Omega$, $R_1 = 1\text{k}\Omega$, $C_1 = 0.1\mu\text{F}$ and L_1 is unknown.

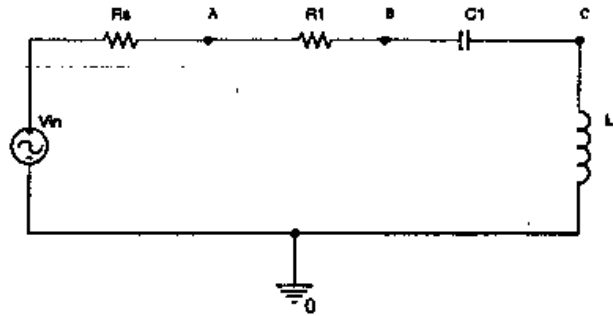

The following plot displays the voltages at points A, B and C.

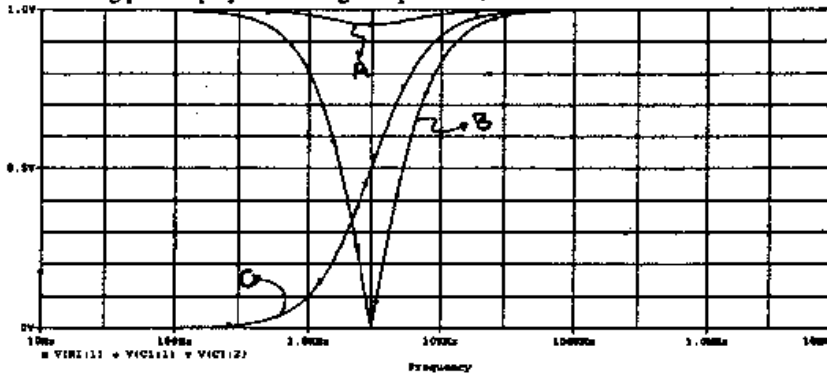

a) Determine which plot goes with which point. (6 points)

b) Find the resonance frequency f_0 from the plot. Notice that the x-axis has logarithmic scale. (6 points)

$$f_0 = 3 \text{ kHz}$$

c) Solve for the unknown inductance. (8 points)

$$\omega_0 = 2\pi f_0 = \frac{1}{\sqrt{LC}} \Rightarrow L = \frac{1}{(2\pi f_0)^2 C} = \frac{1}{(2\pi \times 3000)^2 \times 0.1 \times 10^{-6}}$$

$$\Rightarrow L = 28 \text{ mH}$$

Handwritten scribbles:
~~7/2/01~~
~~2/2/01~~
~~12/2/01~~

Fall 2000

2. Inductance Measurement

The following circuit is constructed using an unknown inductor, a known capacitor, a known resistor and a function generator.

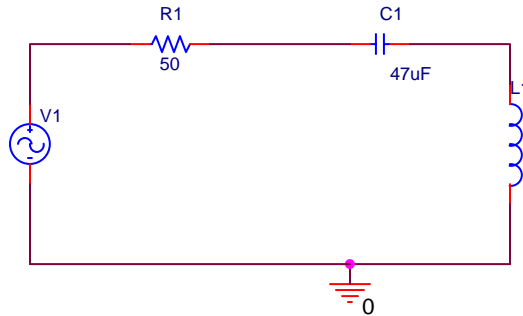

The following plot is obtained for the voltages at the indicated points in the circuit.

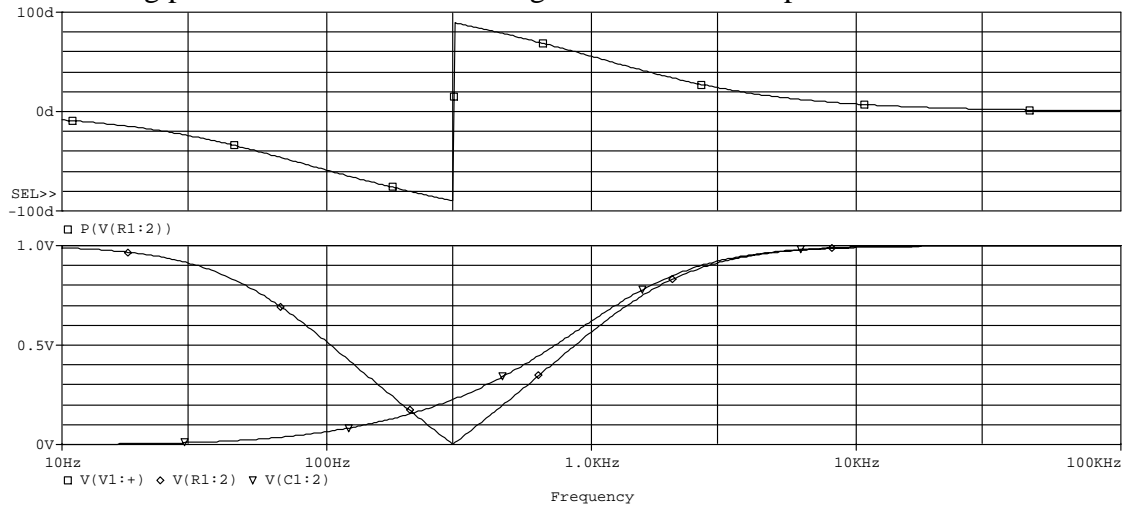

Determine the value of the unknown inductance.

The top trace shows a shift in phase at $f = 300\text{Hz}$ for the voltage between the resistor and the inductor. Why does this happen?

Fall 2000 Solution
(none available)