

ENGR-2300

Electronic Instrumentation

Quiz 3

Fall 2014

Name _____

Section ____

Question I (25 Points) _____

Question II (25 Points) _____

Question III (25 Points) _____

Question IV (25 Points) _____

Total (100 Points) _____

On all questions: **SHOW ALL WORK**. BEGIN WITH FORMULAS, THEN SUBSTITUTE VALUES AND UNITS. No credit will be given for answers that appear without justification. Also, if there is a small flaw in your reasoning, we will not know and not be able to give you credit for what you have correct if you do not provide information on how you solved the problem. Read the entire quiz before answering any questions. Also it may be easier to answer parts of questions out of order.

Some Additional Background

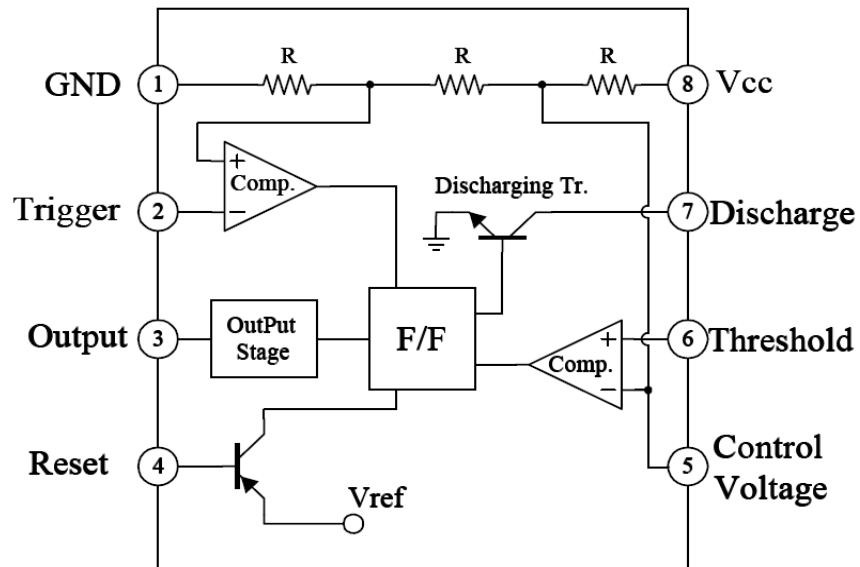



Bay Bridge LED Lights



The Bay Lights is the world's largest LED light sculpture, 1.8 miles wide and 500 feet high. Its 25,000 white LED lights are individually programmed by artist Leo Villareal to create a never repeating, dazzling display through March 2015 across the western span of the Bay Bridge. For six months, a team of electricians from Bleyco Inc. worked Monday through Friday, 8:00 p.m. to 5:00 a.m., to install the piece. Saeed Shahmirzai of Zoon Engineering led the construction effort, which included technical design by Parsons-Brinckerhoff and LED light system by Philips Color Kinetics.

Some Typical LED Operating Info:

	Wavelength (nm)	Color Name	Fwd Voltage (Vf @ 20ma)	Intensity 5mm LEDs	Viewing Angle	LED Dye Material
	940	Infrared	1.5	16mW @50mA	15°	GaAIAs/GaAs -- Gallium Aluminum Arsenide/Gallium Arsenide
	880	Infrared	1.7	18mW @50mA	15°	GaAIAs/GaAs -- Gallium Aluminum Arsenide/Gallium Arsenide
	850	Infrared	1.7	26mW @50mA	15°	GaAIAs/GaAs -- Gallium Aluminum Arsenide/Gallium Aluminum Arsenide
	660	Ultra Red	1.8	2000mcd @50mA	15°	GaAIAs/GaAs -- Gallium Aluminum Arsenide/Gallium Aluminum Arsenide
	635	High Eff. Red	2.0	200mcd @20mA	15°	GaAsP/GaP - Gallium Arsenic Phosphide / Gallium Phosphide
	633	Super Red	2.2	3500mcd @20mA	15°	InGaAIP - Indium Gallium Aluminum Phosphide
	620	Super Orange	2.2	4500mcd @20mA	15°	InGaAIP - Indium Gallium Aluminum Phosphide
	612	Super Orange	2.2	6500mcd @20mA	15°	InGaAIP - Indium Gallium Aluminum Phosphide
	605	Orange	2.1	160mcd @20mA	15°	GaAsP/GaP - Gallium Arsenic Phosphide / Gallium Phosphide
	595	Super Yellow	2.2	5500mcd @20mA	15°	InGaAIP - Indium Gallium Aluminum Phosphide
	592	Super Pure Yellow	2.1	7000mcd @20mA	15°	InGaAIP - Indium Gallium Aluminum Phosphide
	585	Yellow	2.1	100mcd @20mA	15°	GaAsP/GaP - Gallium Arsenic Phosphide / Gallium Phosphide
	4500K	"Incandescent" White	3.6	2000mcd @20mA	20°	SiC/GaN -- Silicon Carbide/Gallium Nitride

★	6500K	Pale White	3.6	4000mcd @20mA	20°	SiC/GaN -- Silicon Carbide/Gallium Nitride
	8000K	Cool White	3.6	6000mcd @20mA	20°	SiC/GaN - Silicon Carbide / Gallium Nitride
	574	Super Lime Yellow	2.4	1000mcd @20mA	15°	InGaAlP - Indium Gallium Aluminum Phosphide
	570	Super Lime Green	2.0	1000mcd @20mA	15°	InGaAlP - Indium Gallium Aluminum Phosphide
	565	High Efficiency Green	2.1	200mcd @20mA	15°	GaP/GaP - Gallium Phosphide/Gallium Phosphide
	560	Super Pure Green	2.1	350mcd @20mA	15°	InGaAlP - Indium Gallium Aluminum Phosphide
	555	Pure Green	2.1	80mcd @20mA	15°	GaP/GaP - Gallium Phosphide/ Gallium Phosphide
	525	Aqua Green	3.5	10,000mcd @20mA	15°	SiC/GaN - Silicon Carbide / Gallium Nitride
★	505	Blue Green	3.5	2000mcd @20mA	45°	SiC/GaN - Silicon Carbide / Gallium Nitride
	470	Super Blue	3.6	3000mcd @20mA	15°	SiC/GaN - Silicon Carbide / Gallium Nitride
	430	Ultra Blue	3.8	100mcd @20mA	15°	SiC/GaN - Silicon Carbide / Gallium Nitride

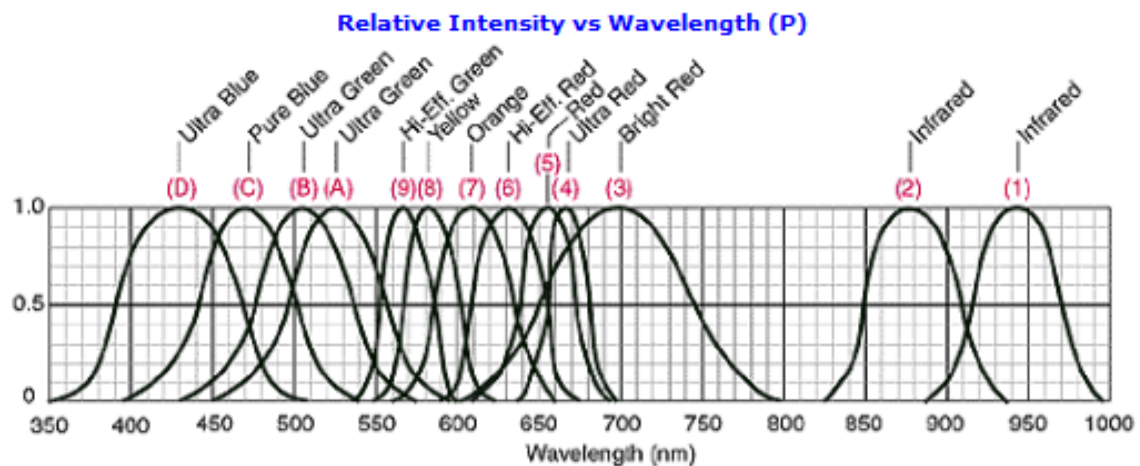

From Wikipedia: A **Zener diode** is a diode which allows current to flow in the forward direction in the same manner as an ideal diode, but also permits it to flow in the reverse direction when the voltage is above a certain value known as the breakdown voltage, "zener knee voltage", "zener voltage", "avalanche point", or "peak inverse voltage".

The device was named after Clarence Zener, who discovered this electrical property. Many diodes described as "zener" diodes rely instead on avalanche breakdown as the mechanism. Both types are used. Common applications include providing a reference voltage for voltage regulators, or to protect other semiconductor devices from momentary voltage pulses.

Type Number	Nominal Zener Voltage $V_Z @ I_{ZT}^{(2)}$ (Volts)	Test Current I_{ZT} (mA)	Maximum Zener Impedance $Z_{ZT} @ I_{ZT}^{(1)}$ (Ω)	Maximum Regulator Current $I_{ZM}^{(2)}$ (mA)	Maximum Reverse Leakage Current	
					$T_A = 25^\circ\text{C}$ $I_R @ V_R = 1\text{V}$ (μA)	$T_A = 150^\circ\text{C}$ $I_R @ V_R = 1\text{V}$ (μA)
1N746A	3.3	20	28	110	10	30
1N747A	3.6	20	24	100	10	30
1N748A	3.9	20	23	95	10	30
1N749A	4.3	20	22	85	2	30
1N750A	4.7	20	19	75	2	30
1N751A	5.1	20	17	70	1	20
1N752A	5.6	20	11	65	1	20
1N753A	6.2	20	7	60	0.1	20
1N754A	6.8	20	5	55	0.1	20
1N755A	7.5	20	6	50	0.1	20
1N756A	8.2	20	8	45	0.1	20
1N757A	9.1	20	10	40	0.1	20
1N758A	10	20	17	35	0.1	20
1N759A	12	20	30	30	0.1	20

Capacitor Codes

Physically larger capacitors, like electrolytics, usually have the capacitance value written simply on them. For smaller capacitors, like ceramics, there are three numbers written to indicate the value. The first two digits of the code represent part of the value; the third digit corresponds to the number of zeros to be added to the first two digits. This is the value in pF.

For Example: CODE: 4 7 3 
 VALUE: 47000 or .047 μF

There is also often a letter after the three numbers. This indicates the tolerance of the value.



Question 1 (25 Points) Astable Multivibrator (An Iconic 555 Timer Application)

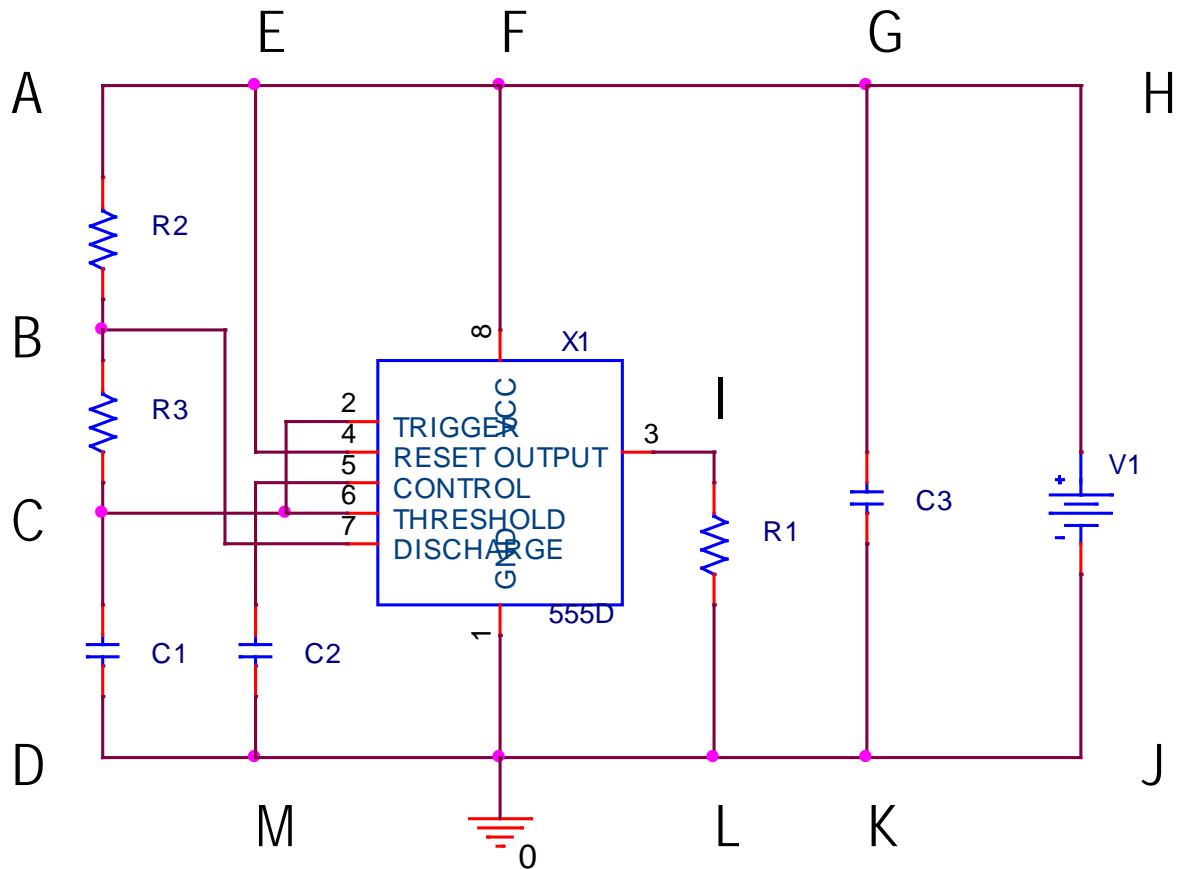

- a. A 555 timer, astable multivibrator is built as above with $R1 = 33k\Omega$, $R2 = 20k\Omega$, $R3 = 40k\Omega$, $C1 = 0.68\mu F$, $C2 = 0.01\mu F$, $C3 = 330\mu F$, and $V1 = 15V$. Determine the **on time** ($T1$) and the **off time** ($T2$) for this circuit. (4 Points)

$$T1 = .693(R2+R3)C1 = .693(60k)(.68\mu F) = 28.3ms \quad T2 = .693R3C1 = (40k)(.68\mu F) = 18.8ms$$

$$T = 47.1ms$$

- b. Plot the output voltage (I) below, showing two full cycles, starting with the output voltage at its maximum (assume = 15V). Label the horizontal and vertical scales. (5 Points)

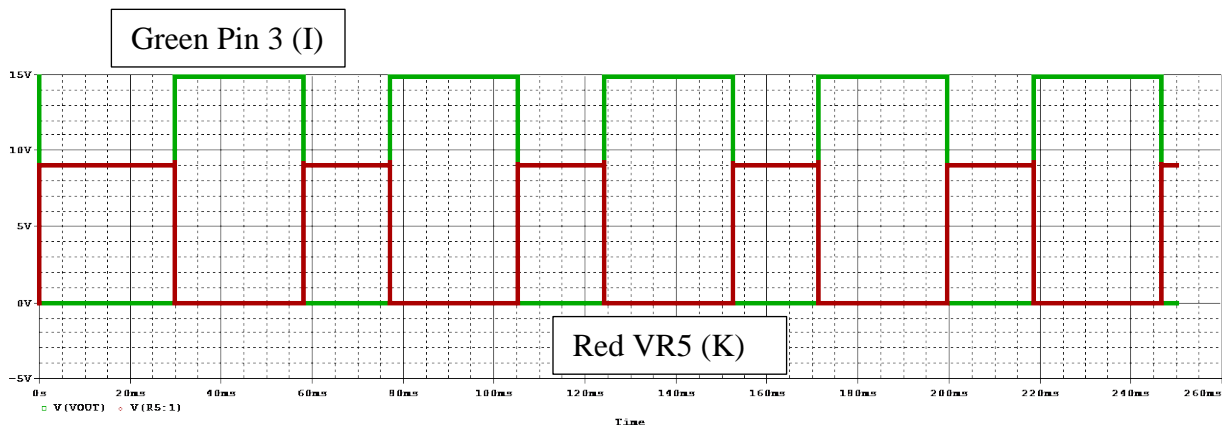

- c. Determine the maximum and minimum voltages at pins 6 (C) and 7 (B). Assume that the circuit is in steady state. (6 Points)

Pin 6 (C): Varies between 1/3 and 2/3 of power supply so 5V and 10V

Pin 7 (B): Varies between $5 + (40k/60k)10 = 11.67$ to $10 + (2/3)5 = 13.33$

- d. Plot two cycles of the voltage at pins 6 & 7. Label the vertical and horizontal scales. (5 Points)

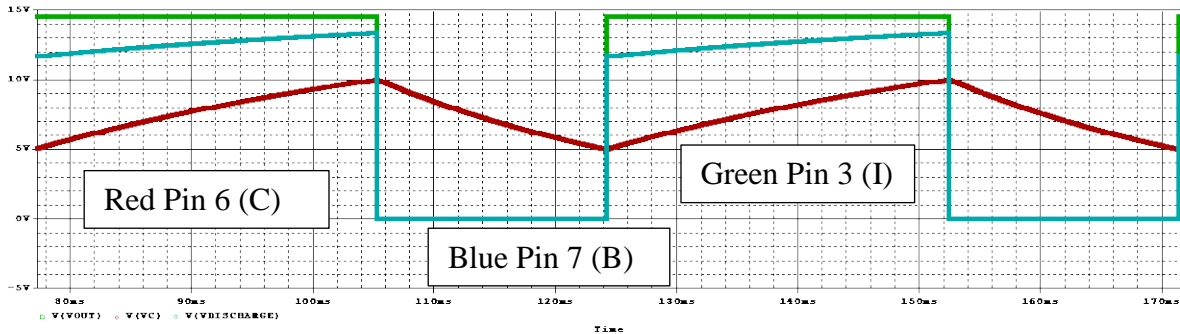

- e. The output of the 555 is used to control a transistor switch. Resistor R1 is disconnected from ground and connected to the base of the transistor. $R4 = 44k\Omega$, $R5 = 66k\Omega$. Plot the output voltage (point K) on the same plot as the 555 output voltage. (5 Points)

When the transistor is on, $V_K = 0V$

When the transistor is off, $V_K = (.6)15 = 9V$

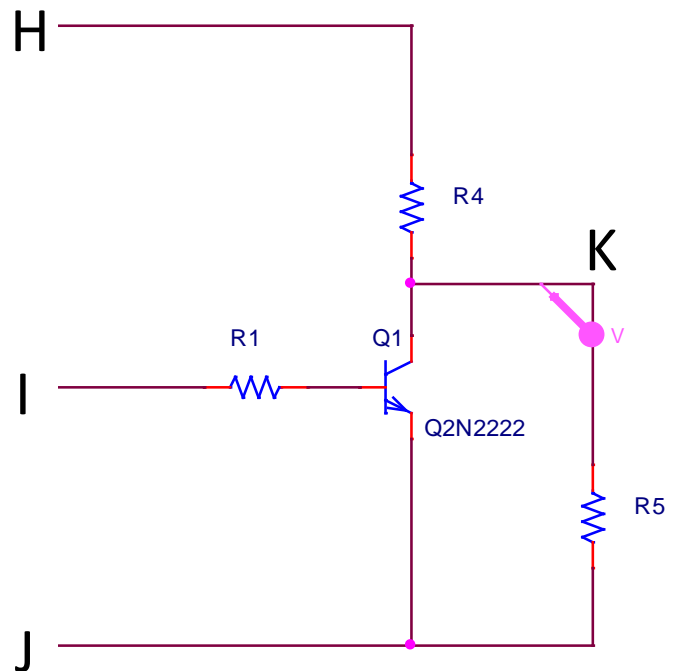

Question 2 (25 Points) Combinational & Sequential Logic Circuits

It is possible to configure any standard logic gate out of either just NOR gates or NAND gates or simple combinations. *Hint: Determine the states of the other points in each circuit as you fill out the tables.*

- a. What logic gate can be realized with either the NAND or NOR configuration shown below? (2 Pts)



From the truth tables for NAND and NOR, use conditions that both inputs are 0 or 1 and we see that Q is the inversion of A. Thus, these are NOT Gates

- b. The following circuit is configured using only NAND gates. Fill in the truth table for this circuit. (4 Pts) The circuit produces the same result as a standard logic device. What device is it? (2 Pts)

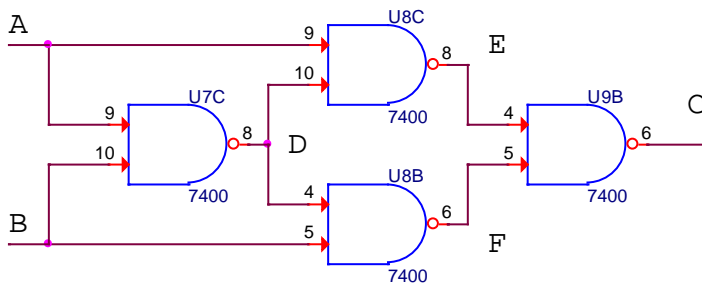

A	B	C	D	E	F
0	0	0	1	1	1
0	1	1	1	1	0
1	0	1	1	0	1
1	1	0	0	1	1

XOR matches the truth table

- c. The following circuit is configured using only NAND gates and NOT gates. Fill in the truth table for this circuit and identify the standard logic gate that behaves in the same manner. (6 Pts) *Again remember the intermediate points.*

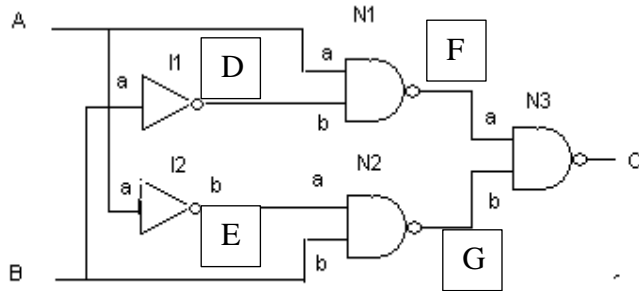

Input A	Input B	Output C	D	E	F	G
0	0	0	1	1	1	1
0	1	1	0	1	1	0
1	0	1	1	0	0	1
1	1	0	0	0	1	1

XOR again from the truth table.

- d. Suppose you go to a nightclub where the doorman's job is to enforce a simple rule: "Everyone in your group must wear a red shirt to come in." You go along with a friend one night. If you're both wearing red shirts, you'll get in. If only one of you is wearing a red shirt, or if neither of you is, neither of you will get in. What logic gate works the same way with two electrical inputs? (2 Pts)

AND

- e. You go to another club further down the street. Here, the person on the door is enforcing a different rule: "A group of people can come in if any one of them is a member." If either you or your friend is a member, or if you both are members, you can both come in. If neither of you is a member, you're both left out in the cold. What logic gate works this way with two electrical inputs? (2 Pts)

OR

- f. Configure the circuit in part c using only NAND gates. Draw the new circuit diagram. (2 Pts)
 Replace the NOT gates with the upper figure in part A.

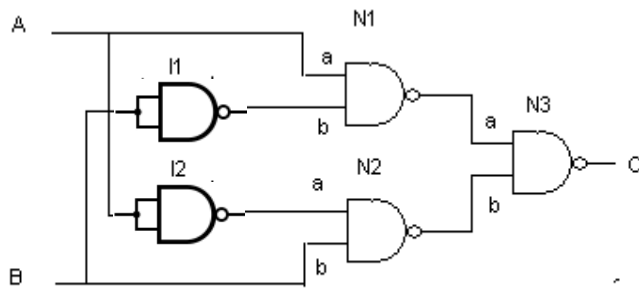

- g. A 4-bit counter is cleared and then receives a string of clock pulses. What are QA, QB, QC and QD after 21 clock pulses? Clearly indicate the state of each signal. (2pts)

QD	QC	QB	QA
0	1	0	1

Count to 15 (1111) and start over counting 6 more times, the first of which is 0, so 5 (0101)

- h. Determine the truth table for the following circuit. (3 Pts) *Note that you have to do two cases, one where Q begins at 0 and one where it begins at 1.*

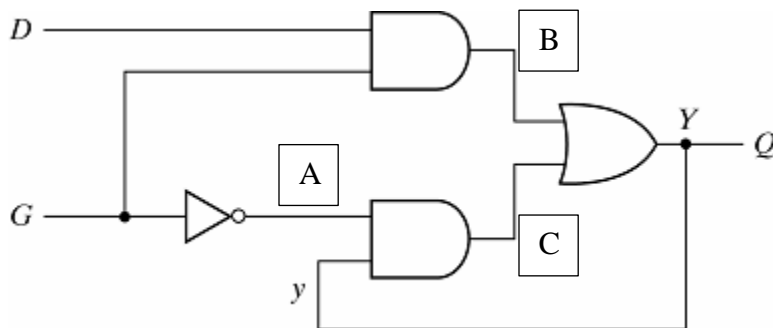

Y will be 1 if either B or C is 1 or both.

Q Before	D	G	A	B	C	Q After
0	0	0	1	0	0	0
0	0	1	0	0	0	0
0	1	0	1	0	0	0
0	1	1	0	1	0	1
1	0	0	1	0	1	1
1	0	1	0	0	0	0
1	1	0	1	0	1	1
1	1	1	0	1	0	1

Question 3 (25 Points) Schmitt Trigger

A 100Hz sine wave (amplitude = 6V) with a 4V offset voltage is passed through a homemade Schmitt Trigger, as shown below.

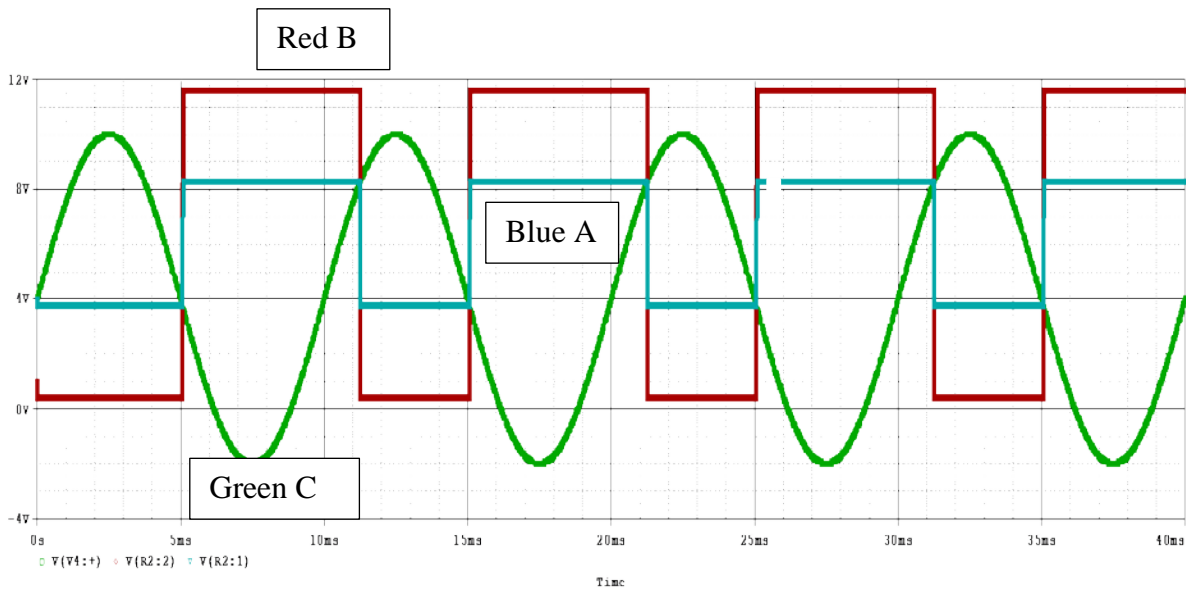
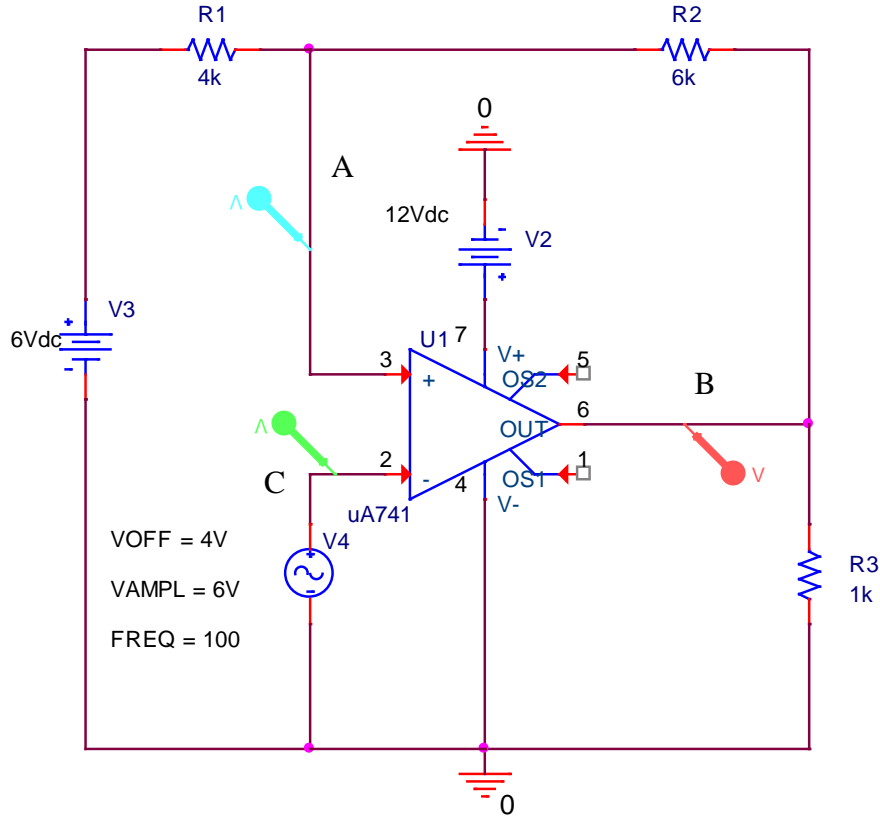

The vertical scale goes from -4V to 12V, the horizontal scale from 0 to 40ms.

- a. Before beginning this problem, consider the circuit below which includes only the voltage source $V5 = 6V$, resistors $R4 = 4k\Omega$ & $R5 = 6k\Omega$, and an unspecified voltage source V_B . Determine the voltage at node A (between the two resistors) in terms of V_B and the given values of $V5$, $R4$ & $R5$. *Note – this is an example of simplifying a problem by focusing on a key sub-circuit.* (4 Points)

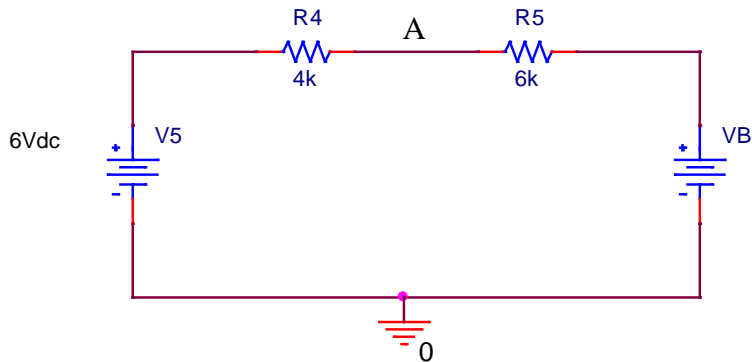

$$V_A = 6 + (V_B - 6)(4/10)$$

The remaining questions pertain to the full Schmitt Trigger circuit.

- b. What are the two possible output voltages (across R3) for this circuit? (2 Points)

Based on the power sources, 12V and 0V

- c. Assuming ideal conditions, what are the two threshold voltages for the Schmitt Trigger? (6 Points)

$$6 + (12 - 6)(.4) = 6 + 2.4 = 8.4V$$

$$6 + (0 - 6)(.4) = 6 - 2.4 = 3.6V$$

- d. Plot the voltages at points A, B and C vs. time on the plot above. (8 Points) Be sure to clearly label the three voltages.

See plot on previous page

- e. A 74393 counter is connected to the output to the circuit, along with a 7414 Schmitt Trigger, which is acting as an inverter in this circuit. The 74393 detects the trailing edges of pulses. Its typical output levels are 3.3V for high and 0.2V for low. Plot the input voltage again (point C), along with the voltages at D and G. (5 Points)

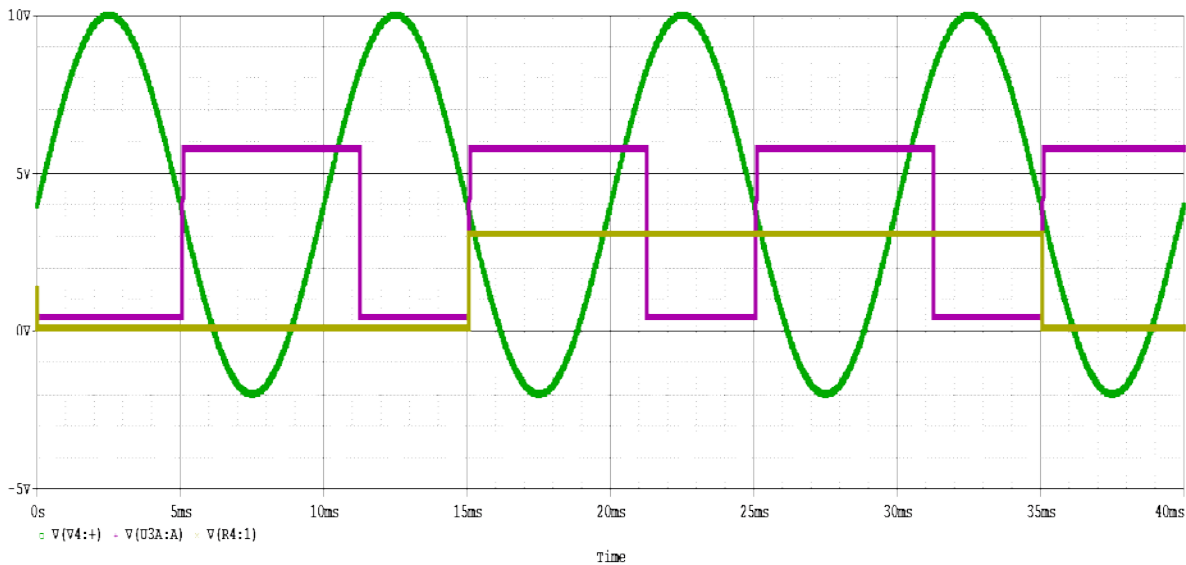
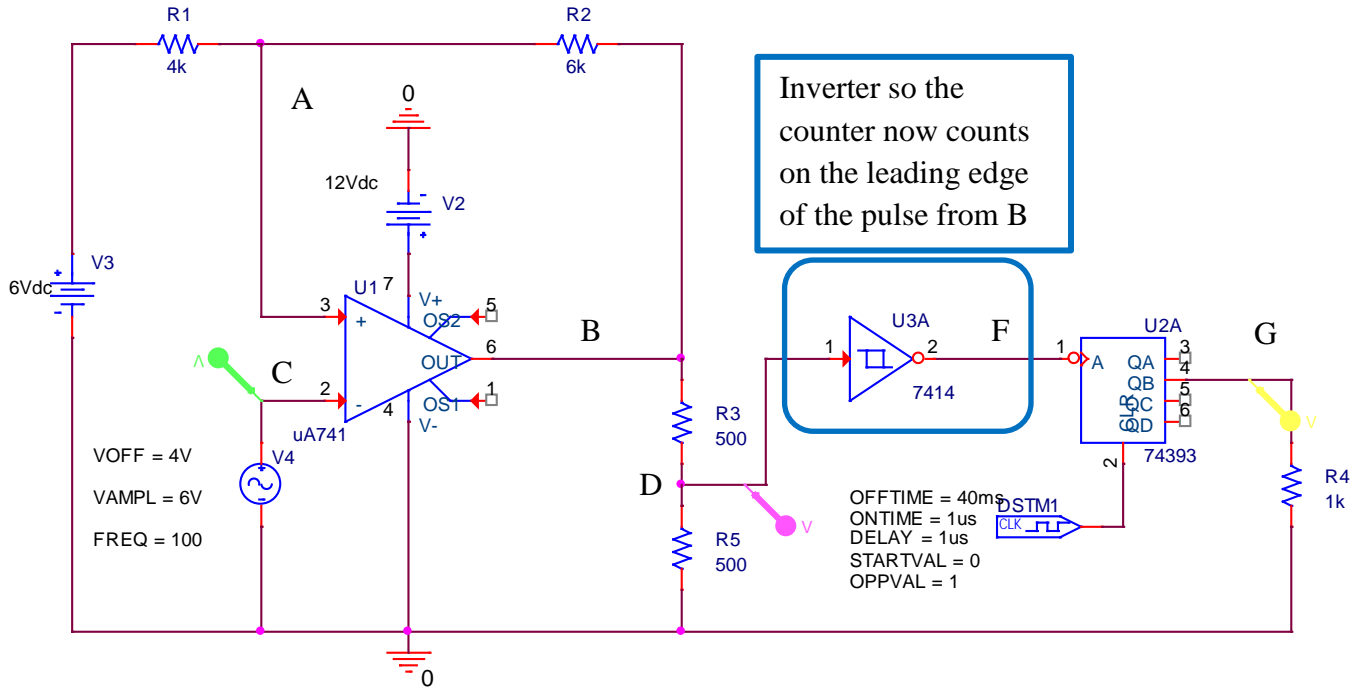

Question 4 (25 Points) Diode Circuits

- a. (3 Pts) There are three voltage ranges shown in the realistic diode I-V curve below: the Breakdown Region, The Forward Bias Region and the Reverse Bias Region. Assuming ideal conditions for a 1N751 Zener Diode (like the one we used for experiments),
- The voltage across the diode $V_D = 0.7V$ in the Forward Bias Region
 - The voltage across the diode $V_D = 5.3V$ in the Breakdown Region
 - The current through the diode $I_D = 0A$ in the Reverse Bias Region

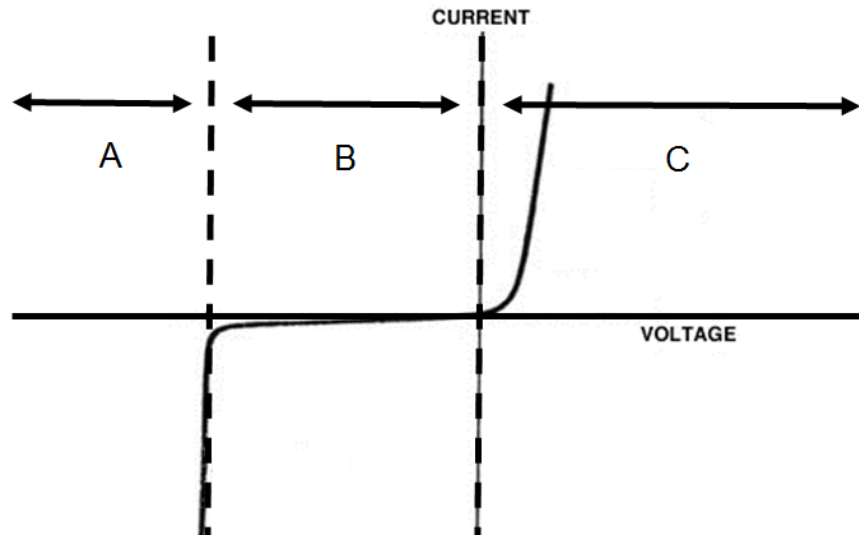

- b. (3 Pts) What is the current through the LED below, if we use the specified yellow LED? (Choose the closest answer.)

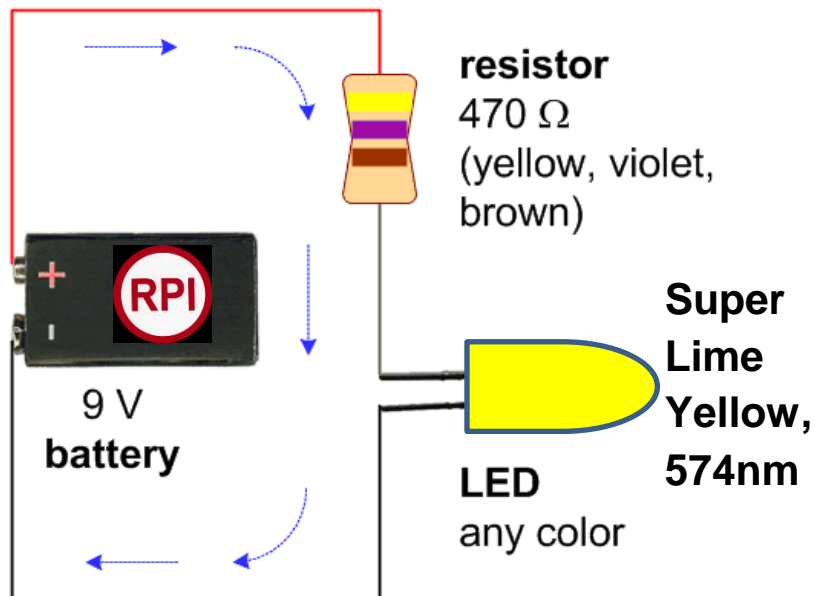

- 5 mA
- 8 mA
- 11 mA
- 14 mA**
- 17 mA

$$(9-2.4)/470 = 14\text{mA}$$

- c. (4 Pts) This problem is inspired by the many low voltage 9V batteries in class these days. The voltage source to the full-wave rectifier circuit simulates what happens when the battery voltages cause the output of an op-amp to saturate. The input voltage is plotted below with the vertical scale going from -8V to +8V. Plot the voltage that results across the load resistor R2 and carefully label key values.

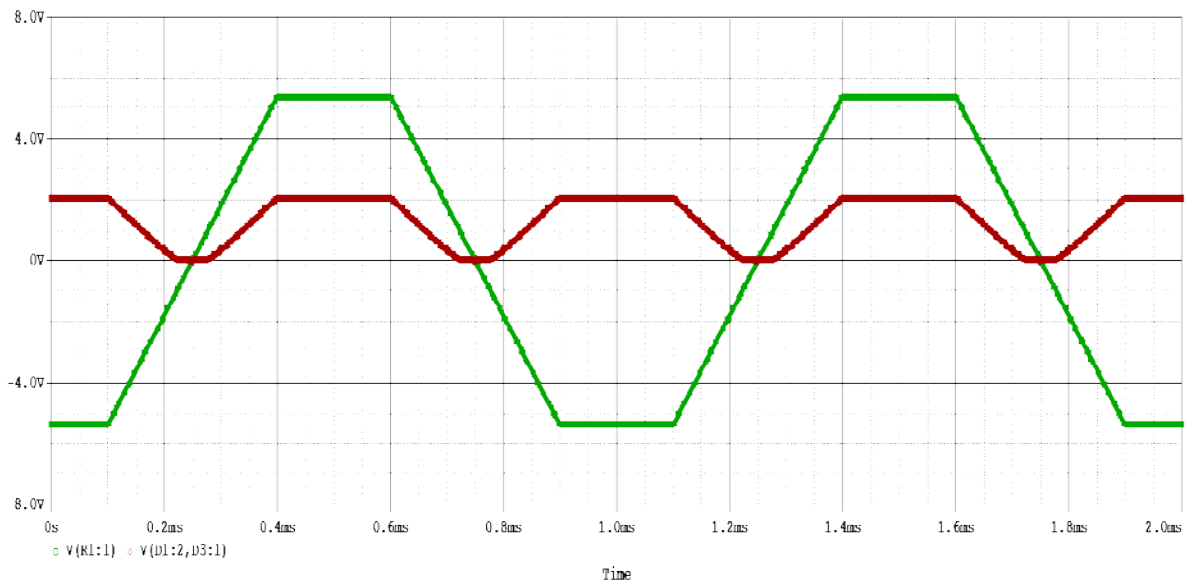
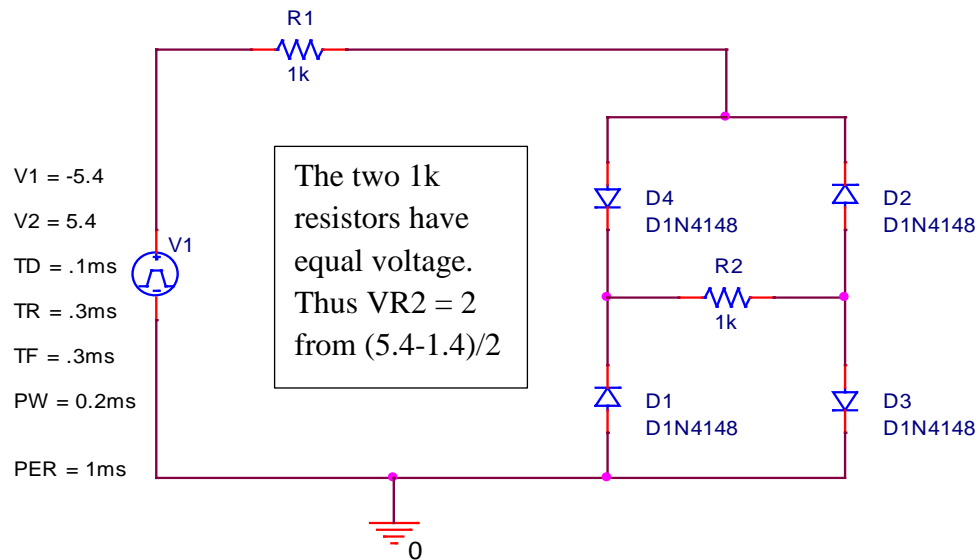

- d. (3 Pts) The voltage across each reverse-biased diode in the full-wave rectifier above is
- Near the source voltage
 - Near twice the source voltage
 - iii. Near half the source voltage
 - Near 0.6 to 0.7 volts
 - Near zero volts

- e. (4 Pts) We now want to use multiple LEDs like a short string of holiday lights. For this purpose, we will use four different color LEDs: Red, Blue Green, Yellow and White. We will use the four LEDs marked with a ★ in the table above. For the power supply, we will use one of two universal AC adapters available online that can output one of the following voltages (switch selectable).

Universal AC Adapter: 15V 16V 18V 18.5V 19V 19.5V 20V 22V 24V 70W

Universal AC Adapter: 3V 4.5V 6V 7.5V 9V 12V 10W

Determine the voltage V_{ww} and resistance R to achieve the desired operating conditions for the series combination of 4 LEDs shown below. Assume that the current is 20mA, since we have to be limited to the smallest maximum current for any of our five LEDs. Use the typical forward bias voltages from the table. The power supply voltage should be the minimum value that will turn on all of the LEDs.

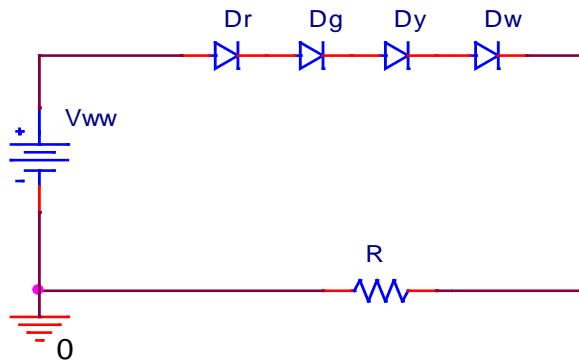

$$1.8 + 3.6 + 2.1 + 3.5 = 11V \text{ and the next largest power supply is } 12V$$

$$R = (12-11)/(0.02) = 1/.02 = 50\Omega$$

- f. (3 Pts) You may have noticed that the Zener diodes we use in class look almost exactly like the signal diodes (except for the number printed on them). Assume that a student builds a half-wave rectifier but accidentally uses a Zener diode, as shown below. The input voltage is plotted with a vertical scale from -20V to +20V. Plot the voltage across the 1k Ω load as a function of time.

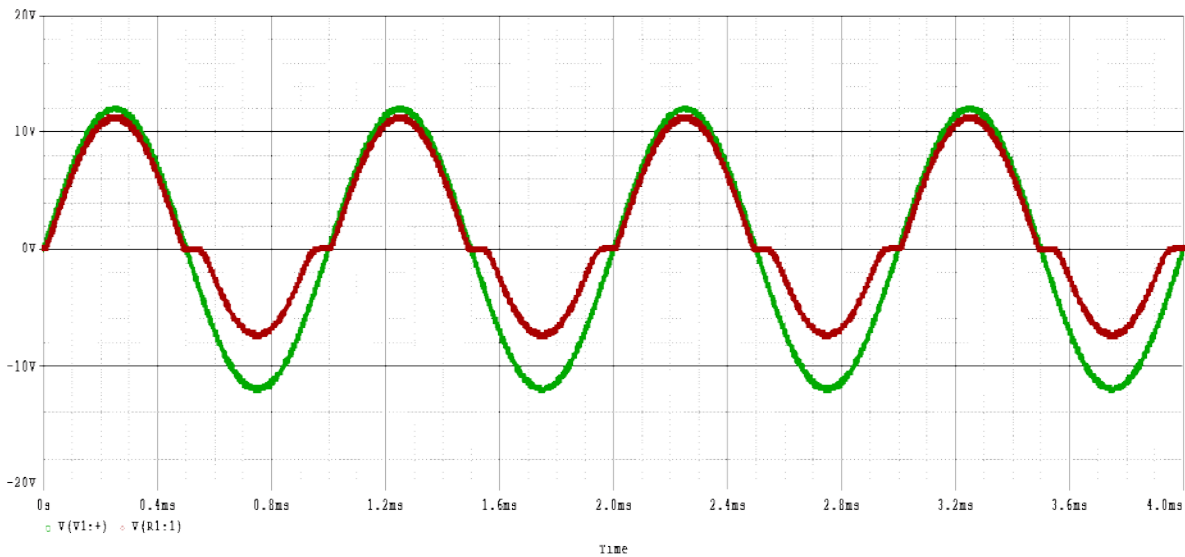
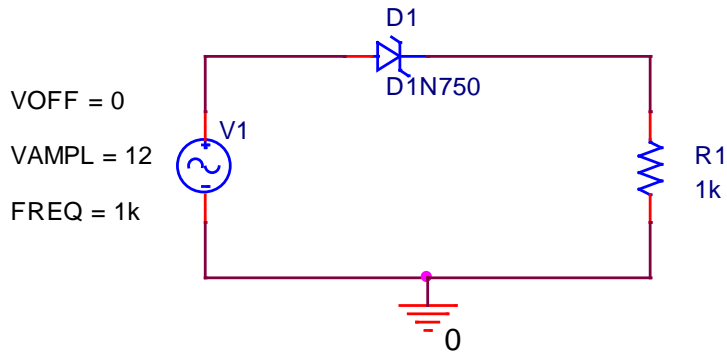

Forward bias, $V_D = 0.7V$; Reverse bias, $V_D = 4.7V$ so peak drops to $12 - 4.7 = 7.3V$

- g. (2 Pts) Also determine the peak power dissipated by the Zener diode in the circuit above.

Peak power is either $(0.7)(12 - 0.7)/1000 = 7.9mW$ or $(4.7)(12 - 4.7)/1000 = 34.3mW$

Based on the maximum voltage in each half cycle.

- h. (3 Pts) The following circuit shows the creativity of engineers in solving one of the basic problems of rectifiers. It is called a precision rectifier. For the given input voltage, plot the output voltage across resistor R3. The vertical scale on the plot goes from -5V to +5V. *Hint: Except for the diodes, this is a standard op-amp configuration. First consider what the output would be without the diodes and then check to see how the diodes respond.*

