

ENGR-2300
Electronic Instrumentation
Quiz 2
Spring 2015

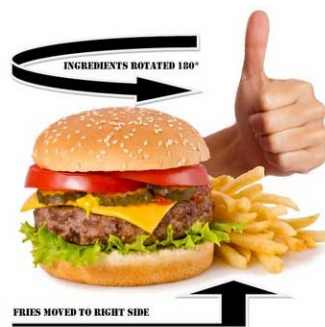

On all questions: **SHOW ALL WORK. BEGIN WITH FORMULAS, THEN SUBSTITUTE VALUES AND UNITS.** No credit will be given for numbers that appear without justification. Read the entire quiz before answering any questions. Also it may be easier to answer parts of questions out of order.

A Few Images in Honor of April Fools Day

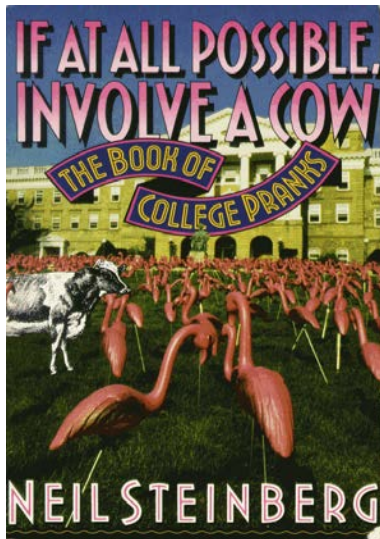
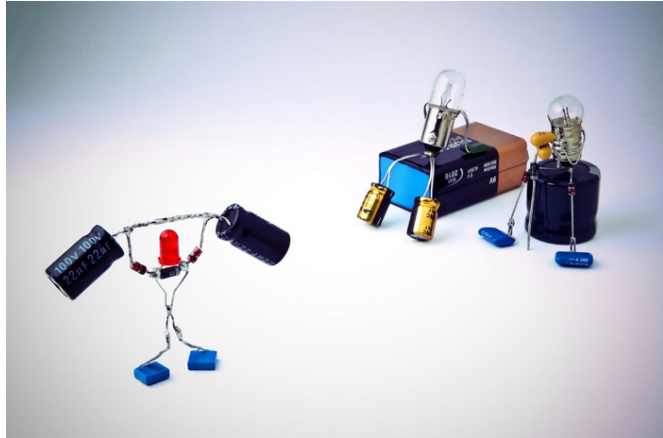
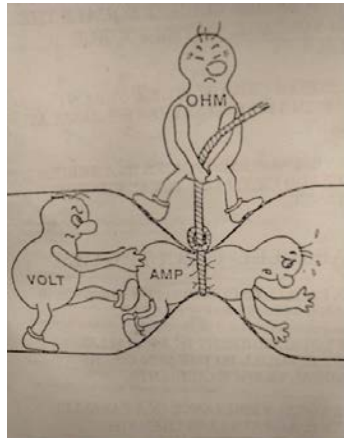
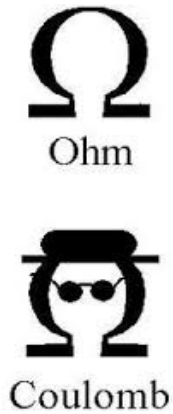

The Whopper may be so big you need two hands to eat it, but for non-ambidextrous customers who were heretofore disadvantaged by having to consume burgers in a right-hand-dominant society Burger King had the answer: The Left-handed Whopper. In 2008 full page ads and press releases announced the new dining choice for lefties, in which placement of condiments like pickles was rotated 180 degrees, "thereby redistributing the weight of the sandwich so that the bulk of the condiments will skew to the left, thereby reducing the amount of lettuce and other toppings from spilling out the right side of the burger." Southpaws could now enjoy their burgers with as much ease as their right-handed fellow citizens. But despite reports of many people earnestly asked for the new sandwich, Burger King later released a statement saying it was all a cruel joke.

I. Thevenin Equivalent Voltage Source

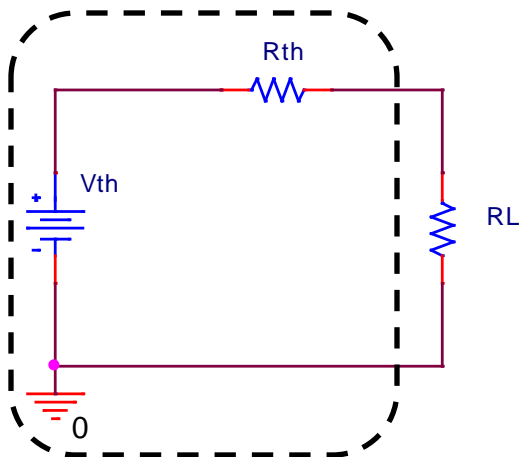

The Thevenin equivalent circuit consists of a voltage source in series with a resistor, which provides a very simple replacement for much more complex circuits. If we have this simple source, analyzing changing loads becomes quite easy.

In this problem, you are to find the Thevenin voltage and resistance for various parts of the circuit below. For clarity, the circuit will be redrawn at each step.

Circuit 1: {4 pts} Find and sketch the Thevenin Equivalent Voltage source for the part of the circuit inside the dashed line (i.e. resistors Ra and Rb and the voltage source Vs).

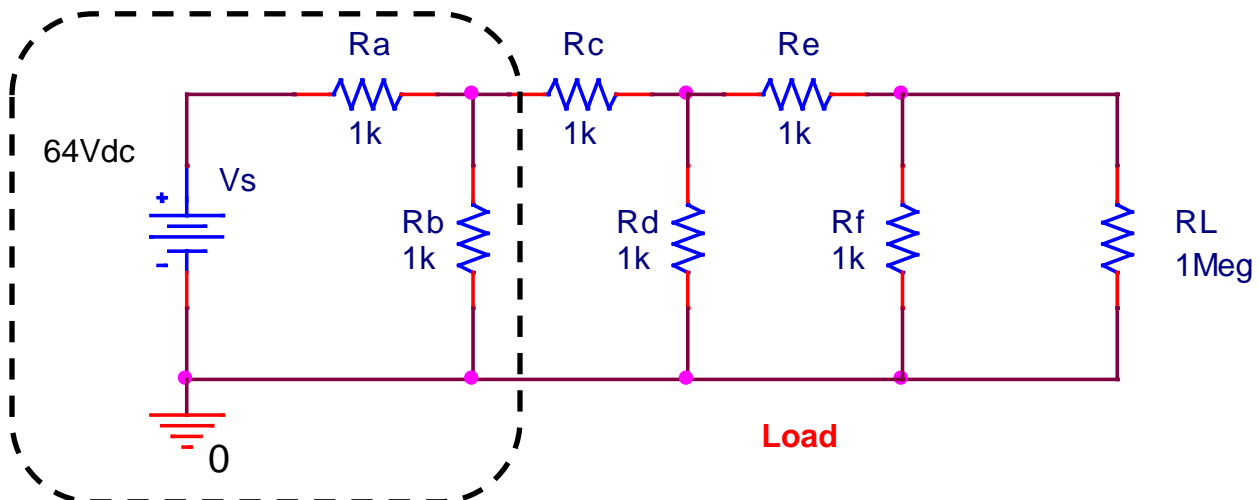

All of the components to the right of the dashed box form the load for this part of the problem.

Open circuit voltage = 32V from voltage divider

Short Vs, then Thevenin Resistance = $1k || 1k = 500\Omega$

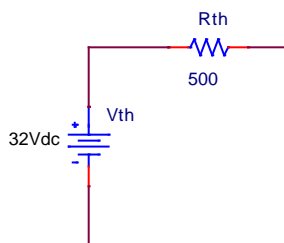

Circuit 2: { 4 pts } Find and sketch the Thevenin Voltage source for the part of the circuit inside the enlarged dashed line (i.e. resistors Ra, Rb, Rc, Rd and the voltage source Vs).

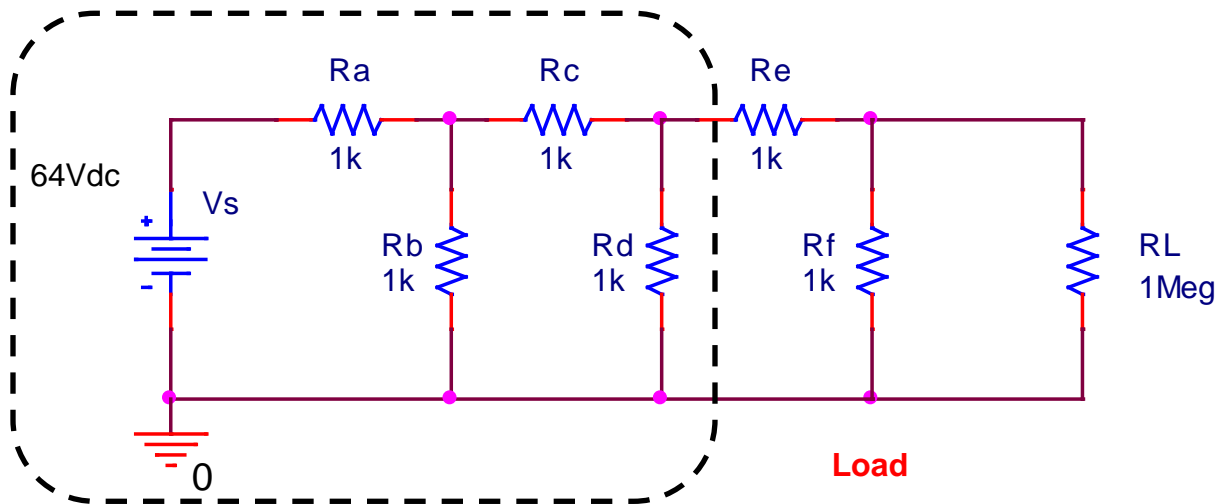

Use the Thevenin Equivalent from the previous part and add the two additional resistors

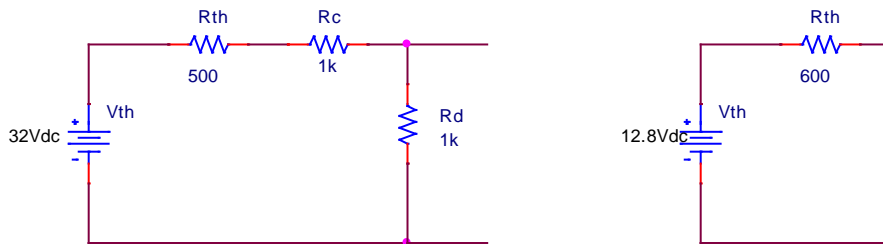

Open circuit voltage is $(1/2.5)32 = 12.8V$

Short V_{th} , then Thevenin Resistance = $1k || 1.5k = 600\Omega$

Circuit 3: { 4 pts } Find and sketch the Thevenin Voltage source for the part of the circuit inside the dashed line (i.e. resistors Ra, Rb, Rc, Rd, Re, Rf and the voltage source Vs).

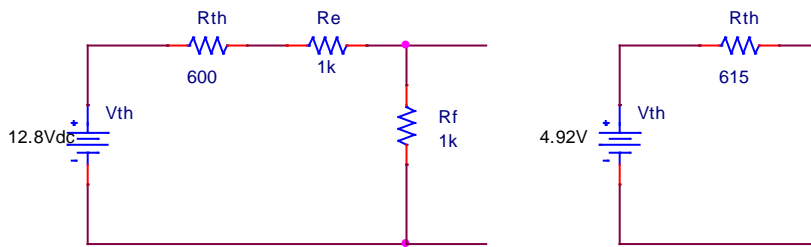
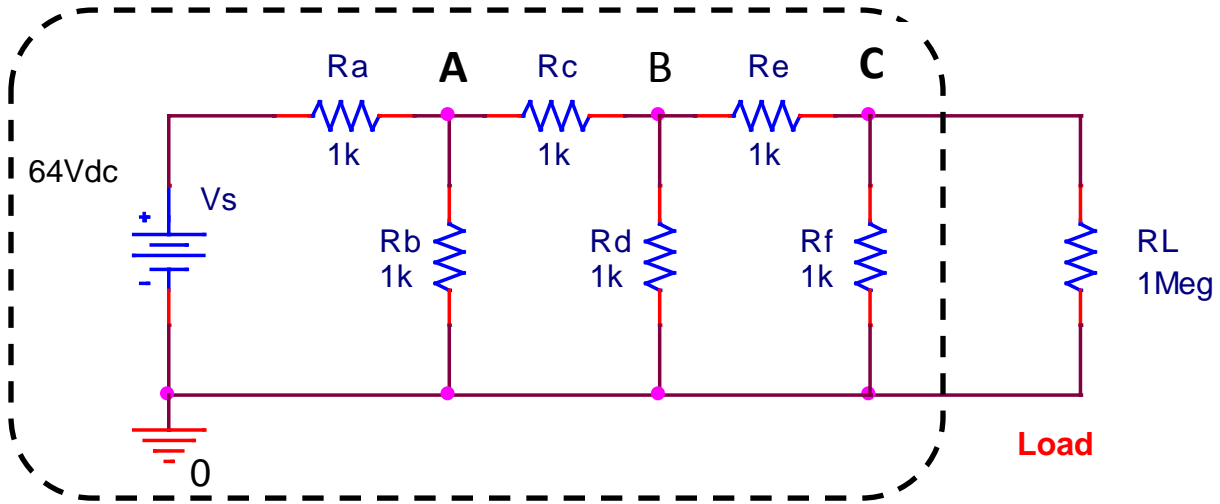

Open circuit voltage is $(1/2.6)12.8 = 4.92V$

Short V_{th} , then Thevenin Resistance = $1k // 1.6k = 615\Omega$

Calculations: { 4 pts } Using the Thevenin sources you obtained above, find the voltage at the two points marked B and C.

V at C is V open circuit because R_L is so large = 4.92V

V at B is (from figure below) $12.8(2/2.6) = 9.85V$

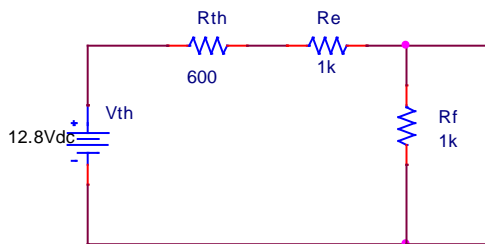

From PSpice:

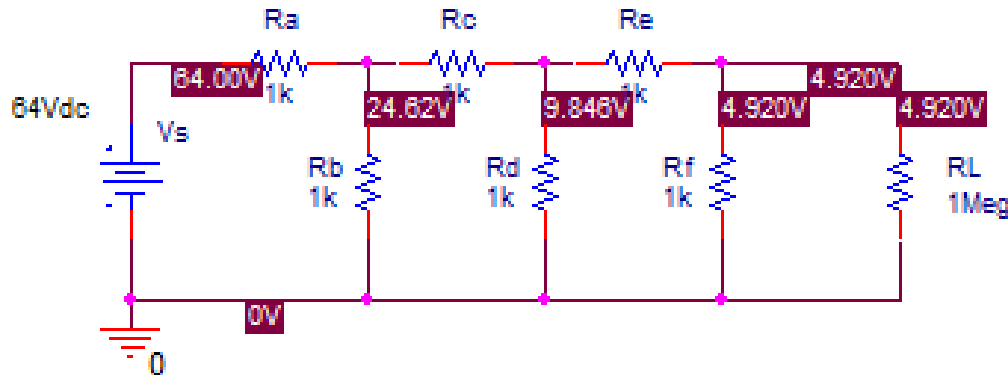

Design: { 4 pts } Imagine that this circuit was created by a student who owned a box full of 1kΩ resistors and thought that by connecting a sequence of three voltage dividers, one after the other, each of which divides the voltage in half, they could produce an output voltage that is $(\frac{1}{2})(\frac{1}{2})(\frac{1}{2})$ or one eighth of the original voltage. Given that you have the same box full of 1kΩ resistors, draw the simplest circuit below that will produce a voltage equal to or very close to 8V across RL.



Standard voltage divider with 7kΩ and 1kΩ made with 1kΩ resistors

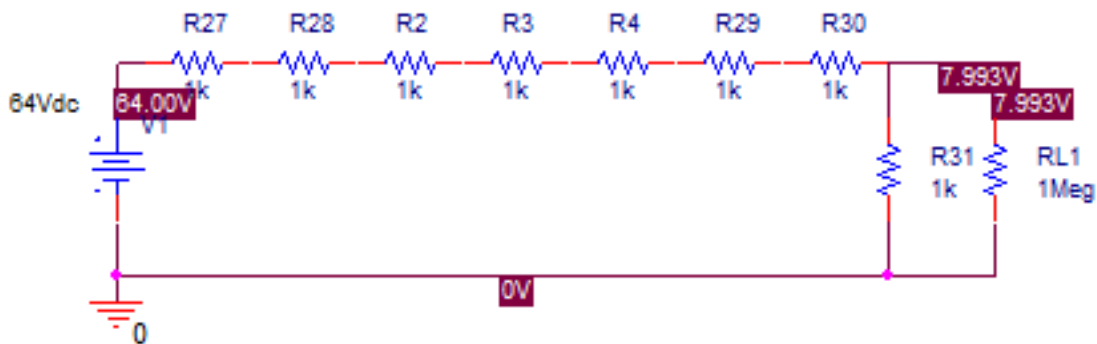

II. Harmonic Oscillators and Math

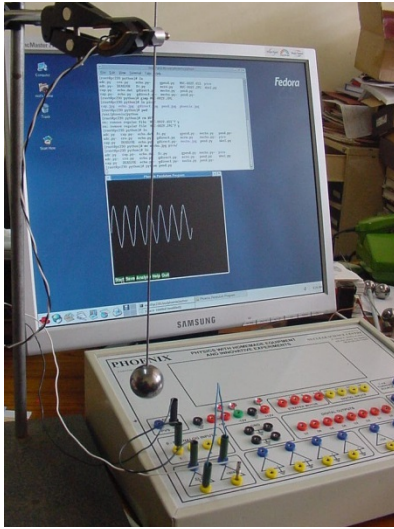

We encounter the harmonic oscillator in an unlimited number of circumstances in engineering and science. For example, you have likely done some kind of a pendulum experiment in Physics. A pendulum experiment from the Inter-University Accelerator Center in New Delhi uses a clever measurement setup to monitor the motion of a simple ball and rod pendulum. They did not have an elaborate sensor, so they used a DC motor as a generator, which they clamped in place and attached the rod to the motor axle. The Phoenix (Physics with Home-made Equipment & Innovative Experiments) system they developed is used to record the data. For clarity, their data are plotted below using Matlab, rather than showing their raw data. Simple motors are also generators, but some include some auxiliary electronics

that block generated signals. If something mechanically drives the axle, the wires that usually go to the power supply will see a voltage induced.

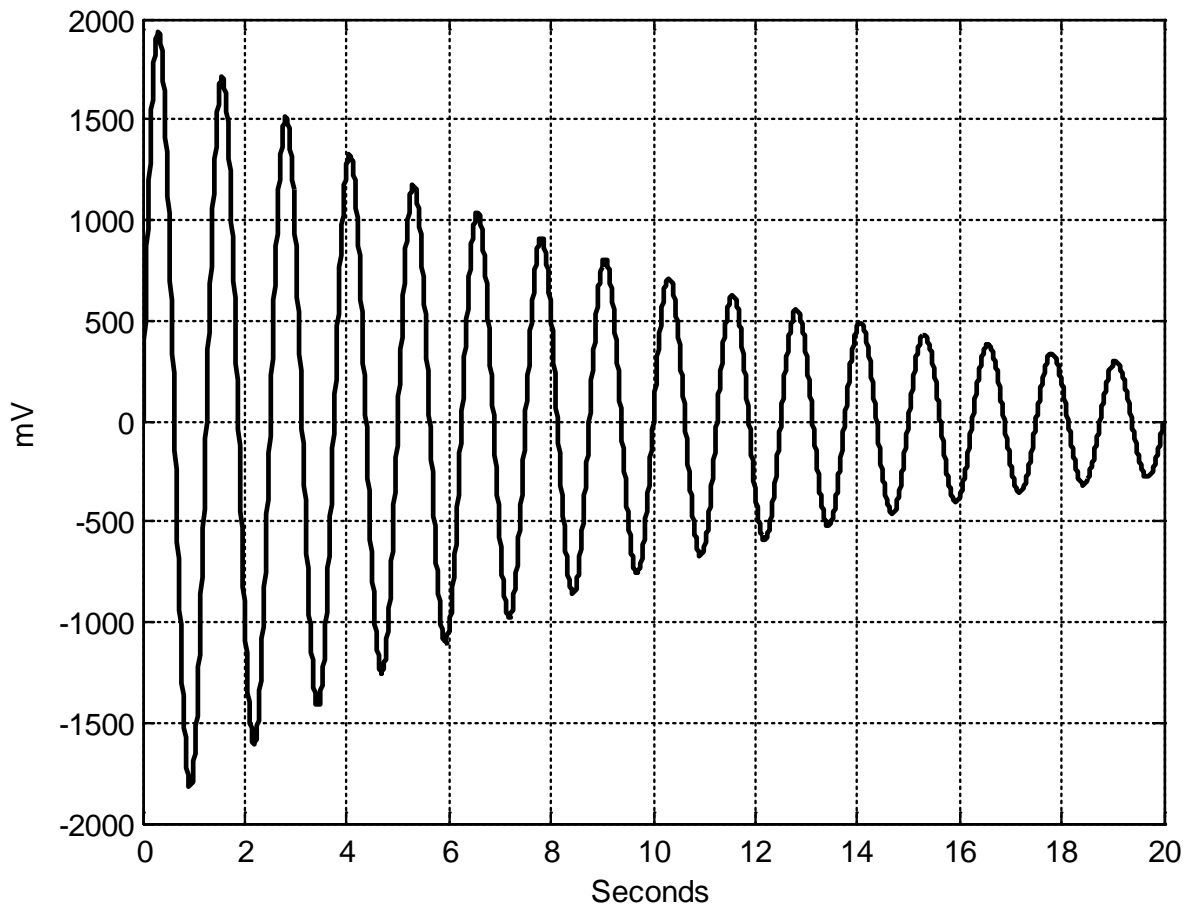

The horizontal scale is time (2 sec per division) and the vertical scale is mV (500mV per division). The horizontal scale is from 0s to 20s. The vertical scale is from -2000mV to 2000mV.

- a. Find the decay constant α and the angular frequency ω for this data. {6 pts}

At $t = 14$, $V = 500\text{mV}$ or close to it. $500 = 2000\exp(-\alpha 14)$ so $\alpha = 0.1$

There are 8 cycles in 10 seconds so $f = 0.8$ and $\omega = 5$

- b. Write the mathematical expression for the voltage in one of the forms $V(t) = Ae^{-\alpha t} \cos \omega t$ or $V(t) = Ae^{-\alpha t} \sin \omega t$, depending on which form fits the data better. Use real values for the constants and provide units where appropriate. {4 pts}

Amplitude at $t = 0$ is 2000mV. Oscillating part of signal starts at zero so the form is

$V(t) = Ae^{-\alpha t} \sin \omega t = 2000e^{-0.1t} \sin 5t \text{ mV}$ Can also use 2V for amplitude.

- c. Generator coil signals are induced by rate of change of the magnetic field passing by so this voltage is proportional to velocity. We know we can write it as $v(t) = Be^{-\alpha t} \cos \omega t$ or $v(t) = Be^{-\alpha t} \sin \omega t$. Keeping only the largest terms, we also know that the ball displacement must be given by $x(t) = Ce^{-\alpha t} \sin \omega t$ or $x(t) = Ce^{-\alpha t} \cos \omega t$. Assume also that the ball displacement at time $t = 0\text{s}$ is -20cm, determine the constant B in the expression for the velocity. Include units in your answer. *Hint: Keep only the largest terms in your expressions.* {6 pts}

Since the velocity is a sine function, the position is a cosine function.

$$x(t) = Ce^{-\alpha t} \cos \omega t = -20e^{-0.1t} \cos 5t$$

$v(t) = \dot{x}(t) = (5)20e^{-0.1t} \sin 5t$ where the term from the derivative of the exponential is dropped because it is much smaller. $v(t) = 100e^{-0.1t} \sin 5t \text{ cm/s}$ or $v(t) = 1e^{-0.1t} \sin 5t \text{ m/s}$

- d. The students doing this experiment also used a clever position measurement to validate their velocity data. They directed a beam of light perpendicular to the motion of the pendulum ball so the ball would block the beam when passing by. The beam is detected by a photocell (Light Dependent Resistor), whose resistance is $1\text{k}\Omega$ when illuminated and $100\text{k}\Omega$ when the light is blocked. The photocell is connected to a $+2\text{V}$ DC supply through resistor R1, forming a voltage divider. The stripes on R1 are Red-Red-Red. Sketch the voltage measured across the photocell vs t on the plot below (an expanded version of the plot above) . {4 pts}

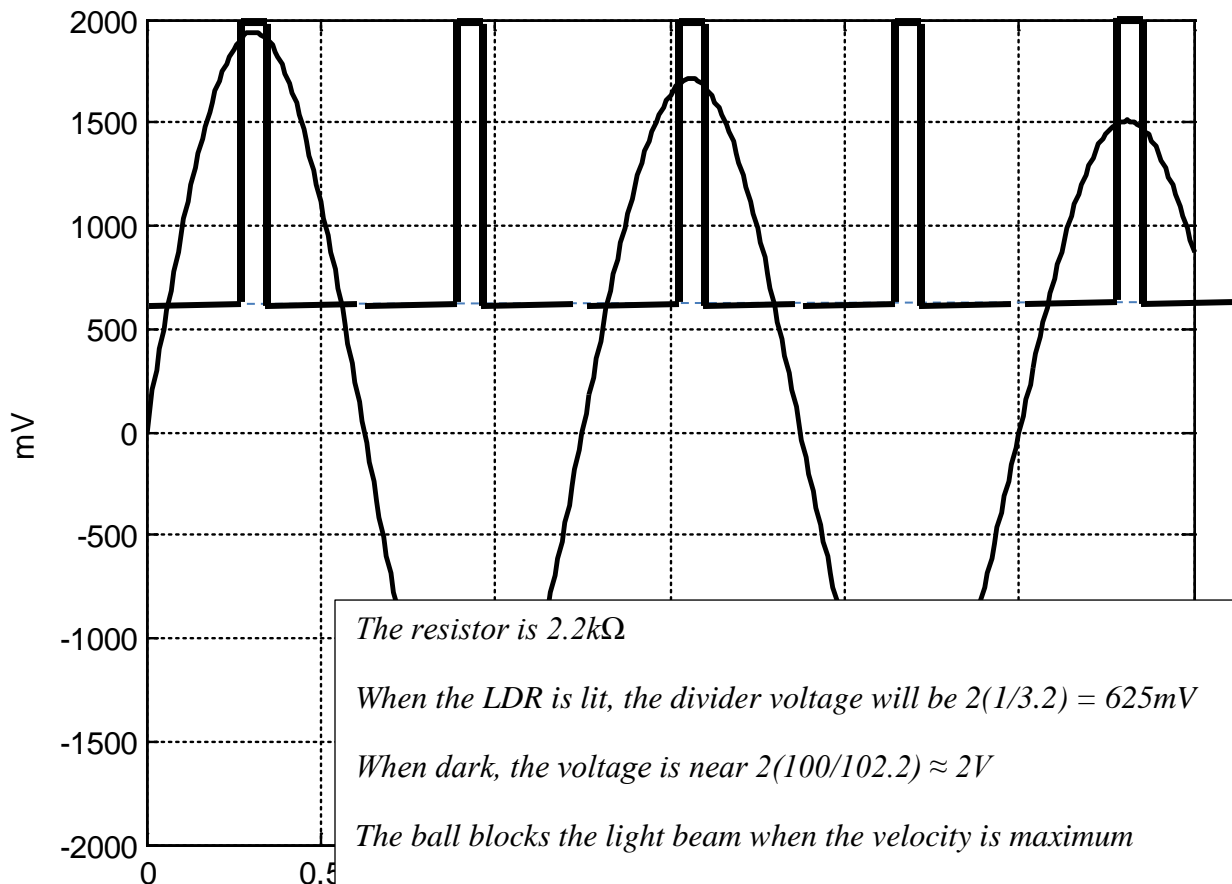
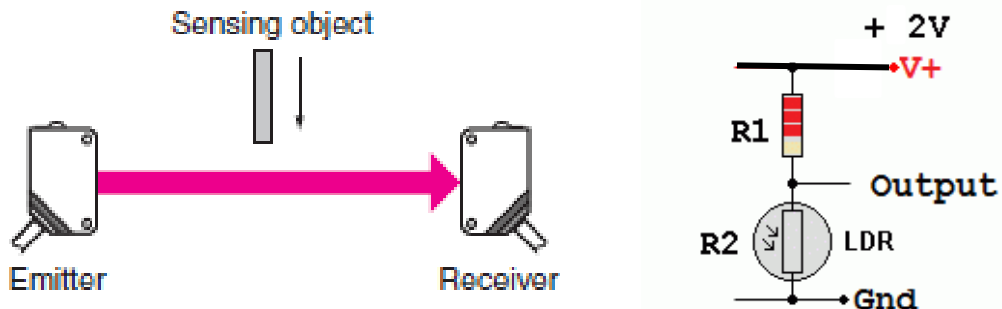

The resistor is $2.2\text{k}\Omega$

When the LDR is lit, the divider voltage will be $2(1/3.2) = 625\text{mV}$

When dark, the voltage is near $2(100/102.2) \approx 2\text{V}$

The ball blocks the light beam when the velocity is maximum

The ball is 2cm vs the displacement of 20cm so the sensor is blocked about 10% of the time.

III. Operational Amplifier Applications

{3 pts} What type of amplifier is each circuit?

- i. A *inverting*
- ii. B *non-inverting*
- iii. C *differential*
- iv. D *adder*
- v. E *differentiator*
- vi. F *integrator*

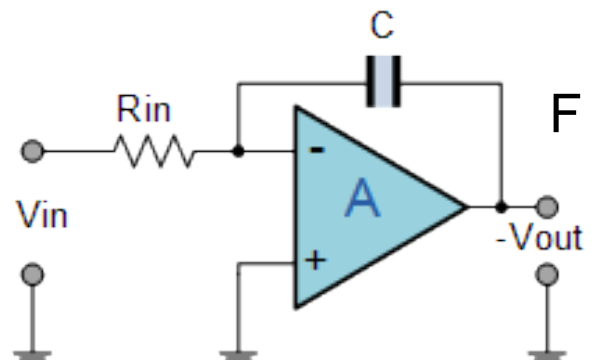
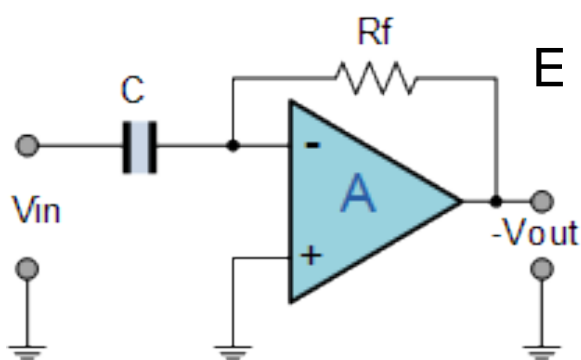
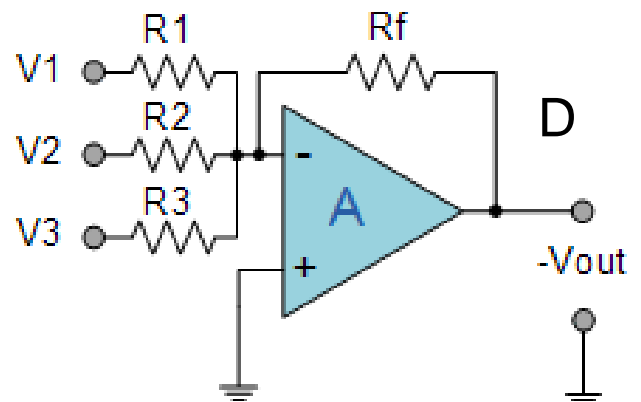
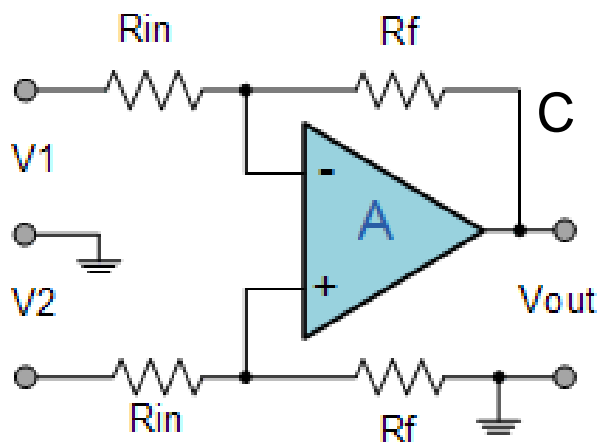
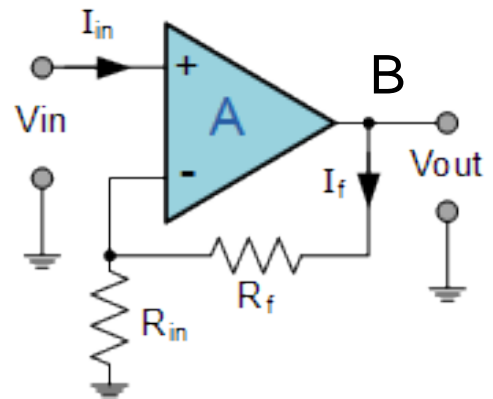
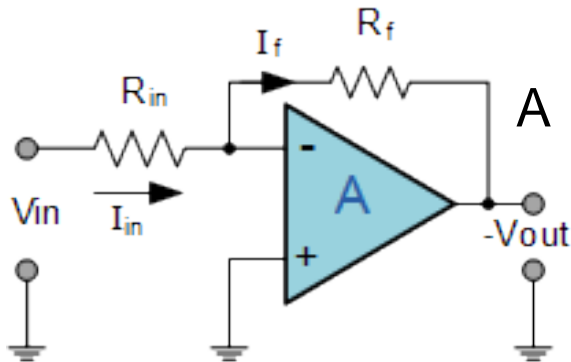

For the next four parts to this question, you will be asked questions about one or more of these standard configurations.

- b. {6 pts} Using circuit D, with two inputs rather than three, we wish to both amplify the sinusoidal part of a given signal and eliminate its offset. This is often the case with voltages from sensors which have to be scaled up or down to be useful and often have offset voltages to be removed. Assume the input voltage is a 1kHz sine wave with an amplitude of 200mV and an offset of 500mV. Also assume that the voltage source we have for removing the offset is a 1.5V battery. Both are included in the circuit below. Given that the feedback resistor $R_f = 10k\Omega$, determine the values for R_1 and R_2 that give the following output voltage. Note that the input voltage is also shown for reference purposes. The voltage scale goes from -2V to +2V and the time scale from 0s to 5ms.

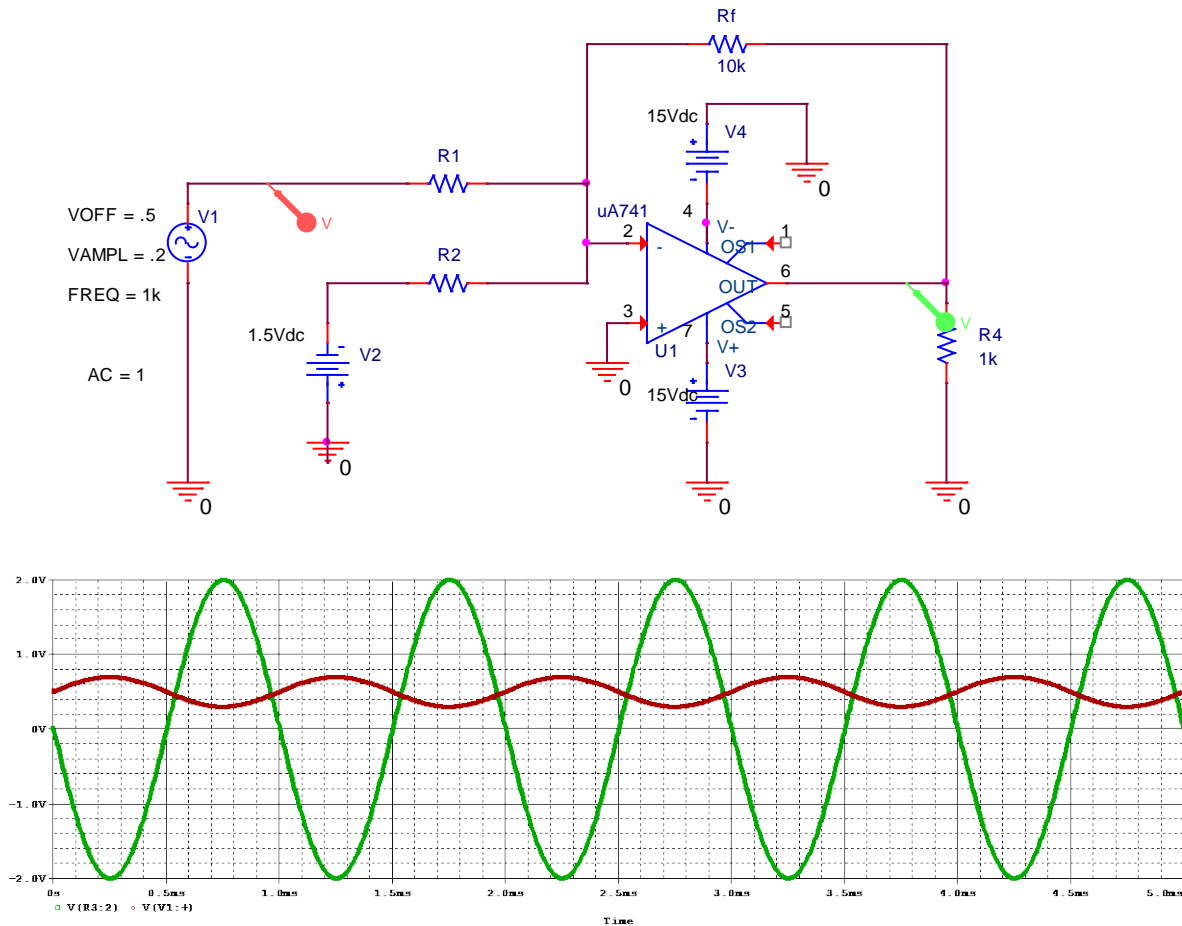

$R_1 = \underline{\quad 1k\Omega \quad}$

$R_2 = \underline{\quad 3k\Omega \quad}$

Output amplitude is 2 or 10x larger than input so $R_f/R_1=10$

Need to subtract $0.5(10) = 5V$ to offset. The battery is in the correct orientation. Then $(1.5)(10)/(3) = 5$ so R_2 is $3k\Omega$

- c. {6 pts} It should be possible to produce essentially the same outcome using circuit E and indeed it is. Shown are the input and output voltages for a particular choice of value for the capacitor C . R_f is still $10k\Omega$. Again, the voltage scale goes from $-2V$ to $+2V$ and the time scale from $0s$ to $5ms$. Determine the value of the capacitor C . Also note that the output is shifted in phase from what was observed in part b. Find the phase shift and explain why it makes sense.

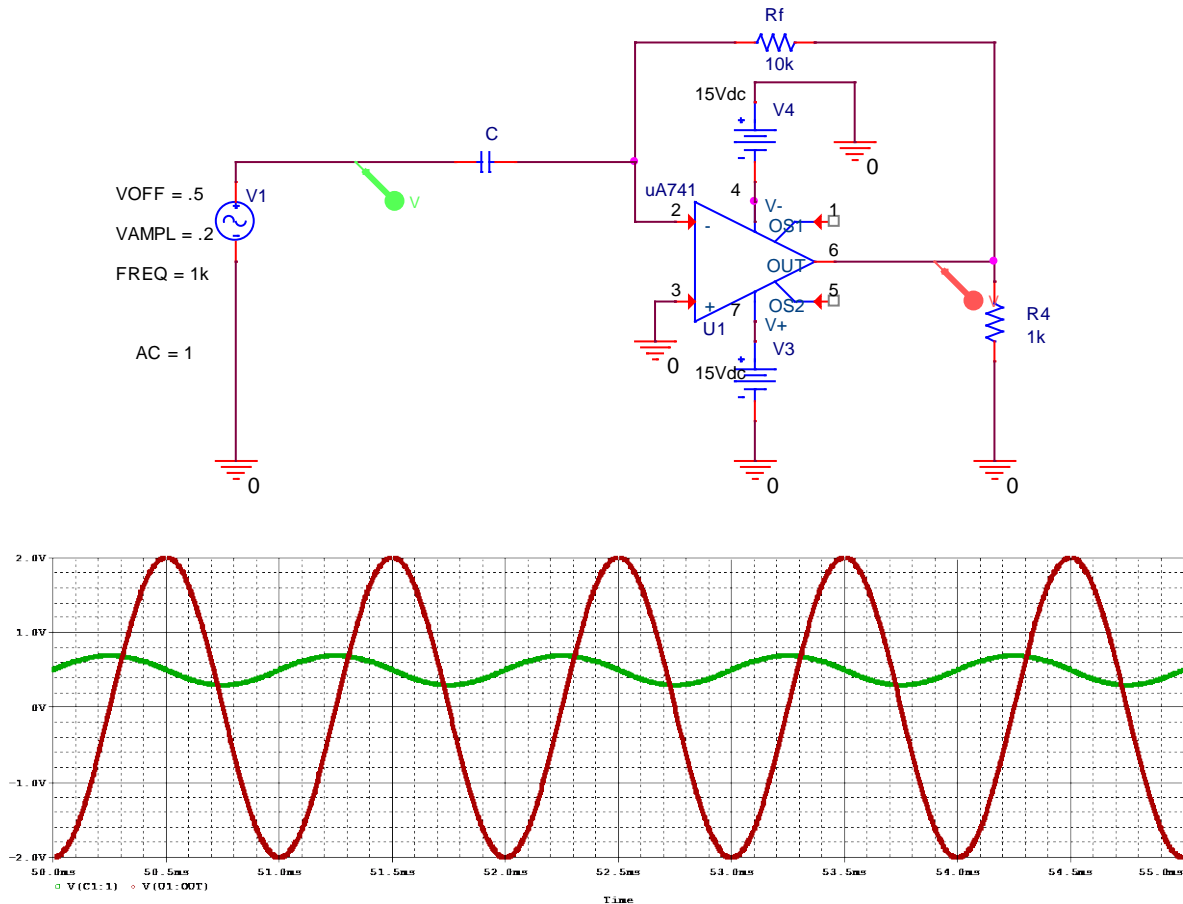

$$C = \underline{.158\mu F}$$

$$\text{Phase Shift} = \underline{-90^\circ}$$

The magnitude of the differentiator output is $2 = RC\omega(.2)$

Thus, $C = .158\mu F$

The input is a sine function. The differentiator produces its derivative with a minus sine or -cosine, which is 90 degrees behind

For grading this question, the sign will be ignored

- d. {5 pts} A version of circuit F above is studied by inputting the square wave shown below. The vertical scale goes from -200mV to +200mV. The horizontal scale covers 2ms. Assume that this signal is applied to the input of the integrator circuit F with $R_{in} = 4k\Omega$ and $C = 0.047\mu F$. Determine and sketch the output voltage as a function of time. *Hint: if you have problems with this, try guessing the solution and then take the derivative and check it against the input.*

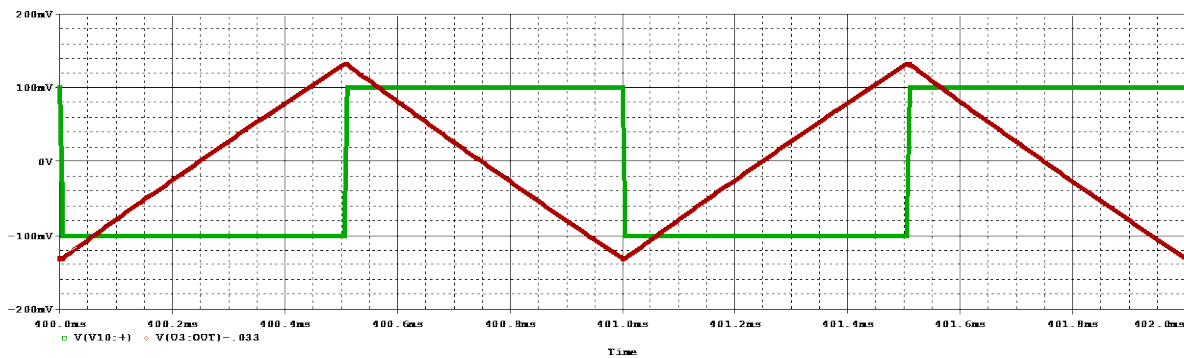
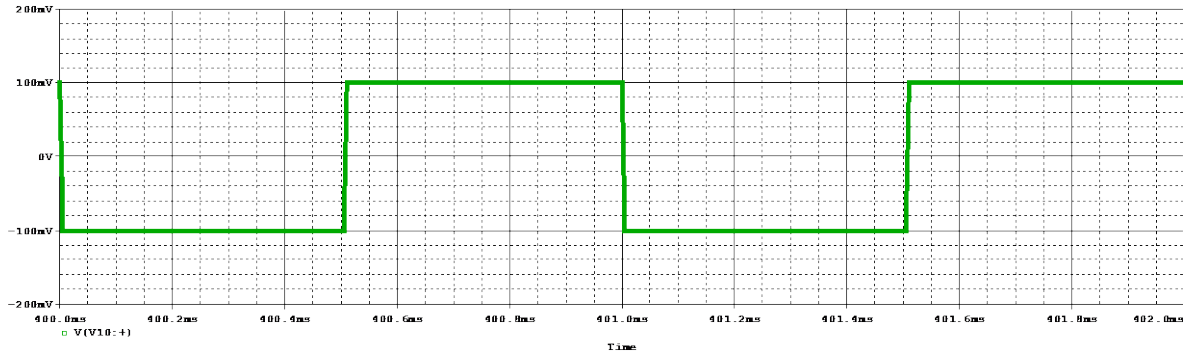

Slope is plus or minus 100mV divided by $RC = 532$

The time for each half period is 0.5ms so the triangular wave increases or decreases by 266mV. This change must be centered around zero so the max value is 133mV and the min value is -133mV, as shown above.

IV. Operational Amplifier and Circuit Fundamentals

- a. {4 pts} **The Inverting and Non-Inverting Amp** configurations are different. To obtain the same gain magnitude (i.e. disregard the sign) with the same feedback resistor R_f , will the input resistor R_{in} for the Non-Inverting Amp be larger, smaller or the same value as the input resistor for the Inverting Amp? Explain your answer.

Larger because its gain is 1 plus the resistor ratio.

- b. {6 pts} **Finding Input Impedances Z_{in}** Before addressing the input impedance of two op-amp configurations, we should remind ourselves how we go about finding an unknown resistance if we do not have an Ohm-Meter. We can do this by connecting a known voltage source (with known voltage and resistance) to the unknown resistance, forming a voltage divider. In the circuit at the left, assume we know V_S and R_S and are able to measure V_L when Z_L is connected to the source. From the known quantities V_S , R_S , and V_L , write an equation to find the value of $Z_L = f(V_S, R_S, V_L) = ?$

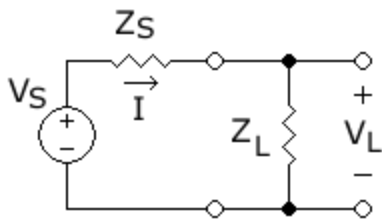

$$V_L = V_S \frac{Z_L}{Z_S + Z_L} \text{ or } V_L(Z_S + Z_L) = V_S Z_L \text{ or } Z_L = \frac{V_L Z_S}{V_S - V_L}$$

- c. {4 pts} **Inverting and Non-Inverting Amps** A very significant difference in these amplifiers is their input impedance Z_{in} . For the circuits A and B in the previous problem, what are the input impedances equal to? *Hint: In the space below, draw each circuit driven by a Thevenin Source like the one used in part b. To keep things simple, choose R_S for the source to be the same as R_1 .*

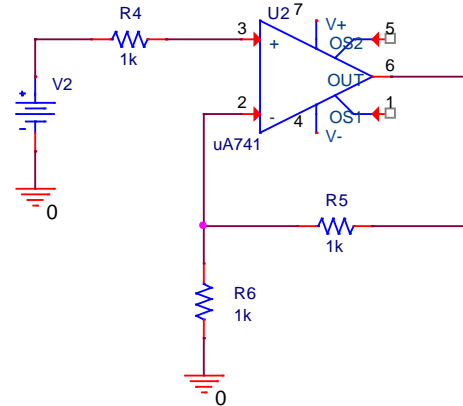
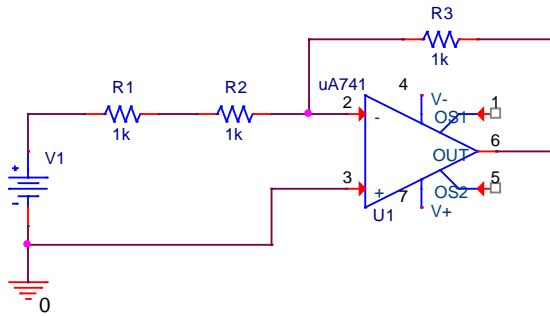

The R_1 and R_2 must be added together so the gain of the inverting amplifier is half when the $1k$ resistor is added, so the input resistance is $1k\Omega$. For the non-inverting amp, there is no current through R_4 so the gain is the same and the input impedance is infinite (or at least really large)

For the next question, we return to the basic circuit without the additional source resistor.

- d. {6 pts} **Inverting and Non-Inverting Amps** We continue to compare the properties of these two common amplifiers by looking at the amount of current through and power dissipated by the input resistor (R_{in}) and feedback resistor (R_f) in the two circuits. For simplicity, we will consider a specific case: $R_{in} = 2k\Omega$ and $R_f = 20k\Omega$.
- What is the gain for each type of amplifier?

Inverting: gain is 10

Non-inverting: gain is 11

- For an input voltage of $1V$, what is the current through R_{in} and R_f for each type of amplifier? This source is ideal and has no impedance.

The currents are identical and equal to $1V$ divided by $2k$ or $0.5mA$. This current is determined by R_1 but continues through R_f in both cases because the op-amp inputs draw no current.

- What is the power dissipated in R_{in} and R_f for each type of amplifier?

For R_1 : $P = (1V)(.5mA) = 0.5mW$ For R_f : $P = (10V)(0.5mA) = 5mW$

V. Concepts, Troubleshooting and Data Analysis

- a. **Resistor Color Code** {4 pts} On March 28, Wisconsin beat Arizona 85 to 79 in the Elite Eight of the NCAA Basketball Tournament. Write down the three colors of the resistor color code that match these two numbers.
- 85 *Gray – Green – Black*
 - 79 *Violet – White – Black*
- b. **Creativity** {4 pts} An EI student wakes up one morning during Spring Break and has a *Eureka!* moment where they think they have come up with a clever new circuit. Since the voltage divider relationship shows how it is possible to step-down a voltage, it seemed reasonable that by turning the divider around, it should be possible to step-up the voltage. The student conceives of the following circuit to increase a voltage from 8V to 64V and to measure it with their Analog Discovery board (represented by the 1Meg Ω resistor). Approximately, what voltage will the student measure at point A? Should the student be disappointed or ask for extra credit for such a good idea?

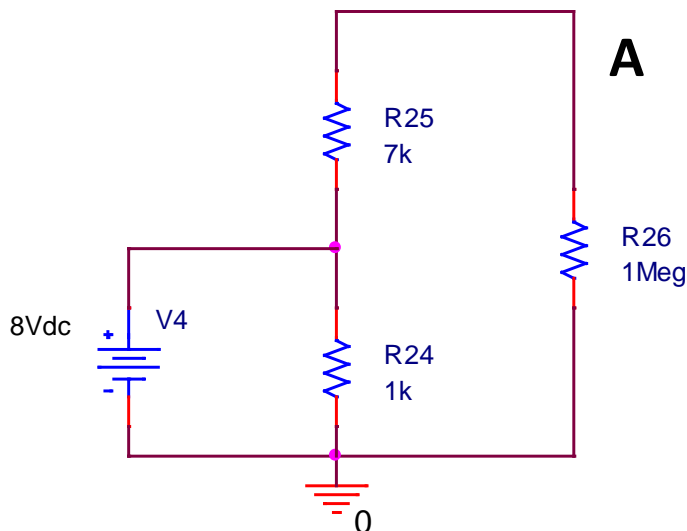

This is two voltage dividers in parallel. Since $1\text{Meg} \gg 7\text{k}$ the voltage at A will be about 8V. The student should be disappointed.

- c. **Classroom Knowledge** {2pts} Where is the electrical tape found in our classroom?

By the reels of wire near the two doors to the room at the front and back.

- d. **Triggering** {4 pts} Shown below is an example Analog Discovery Oscilloscope display showing a sinusoidal voltage signal. The vertical scale is 1V/div and the horizontal scale is 0.2ms/div. Analog Discovery shows the trigger voltage level and time with solid triangles at the right side and top of the scope window, respectively. Both of the triangles are circled to make them easier to find. The triggering for this particular display is set to occur when the signal level is falling. Find the trigger point on the signal and then redraw the signal as it will be observed if the triggering is changed to rising. Please draw neatly and explain your answer.

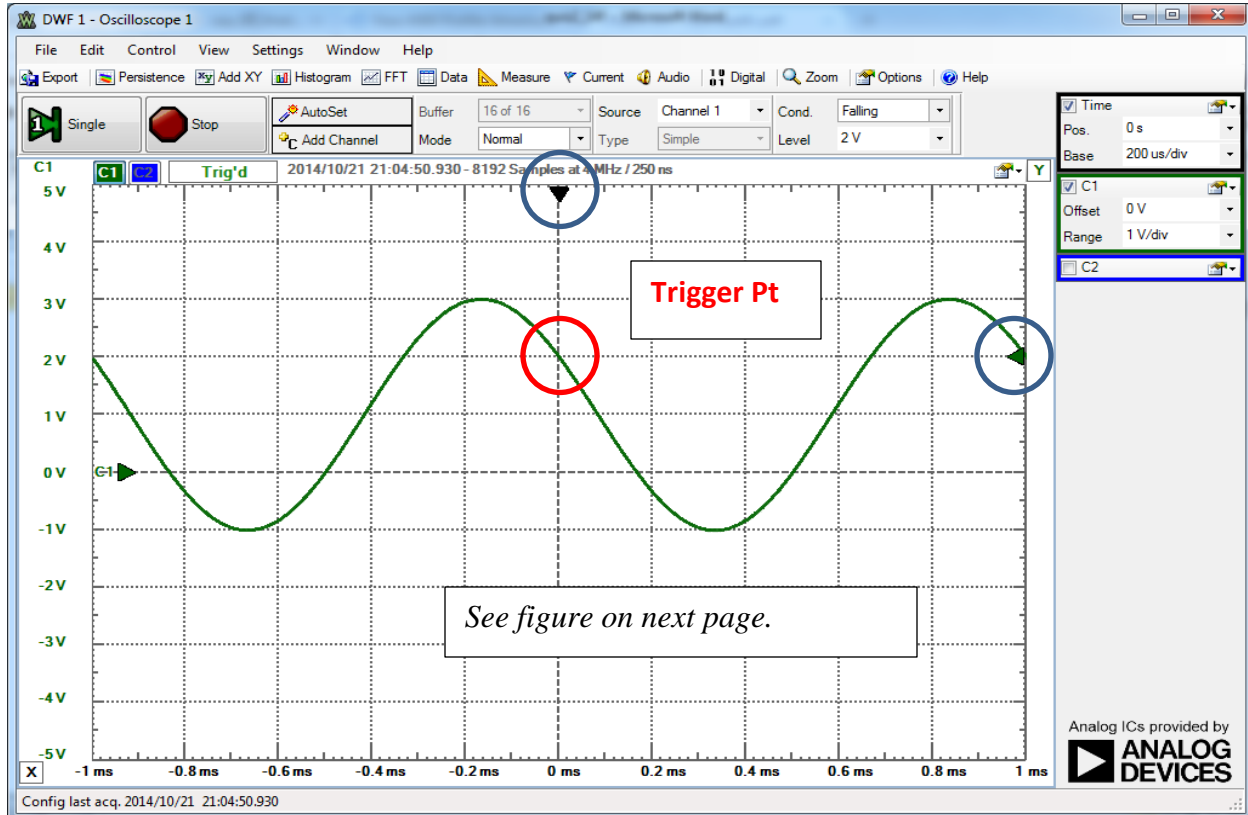

- e. **Experiment and Project Tasks** {2 pts} True or false?

- Before beginning a lab, at least one team member must read over and be generally acquainted with the experiment or project write-up and the other **required reading** materials listed on the EILinks page.
- Before beginning a lab, hand-drawn circuit diagrams must be prepared for all circuits either to be analyzed using PSpice or physically built and characterized using your Analog Discovery board.

Both True!!!!

- f. **Black Box Circuit** {4 pts} There is a circuit in a black box that produces an output voltage when turned on. We expect that it can be represented by a Thevenin Equivalent source with voltage V_{th} and resistance R_{th} . To test it out, the following circuit was built and the voltage measured across a series of load resistors.

R_{Load}	10Ω	100Ω	$1k\Omega$	$10k\Omega$	$100k\Omega$
V_{Load}	1.77V	13.75V	42.3V	53.4V	54.84V

Determine the values for V_{th} and R_{th} : $V_{th} = 55V$ and $R_{th} = 300\Omega$ (Try the voltage divider equation on the highlighted values to see that these are correct.)

