

## ENGR-2300

## Electronic Instrumentation

## Quiz 3

Fall 2022

**Print Name** \_\_\_\_\_ **RIN** \_\_\_\_\_

**Section** \_\_\_\_\_

I have read, understood, and abided by the Collaboration and Academic Dishonesty statement in the course syllabus. The work presented here was solely performed by me.

Signature: \_\_\_\_\_

Date: \_\_\_\_\_

On all questions: SHOW ALL WORK. BEGIN WITH FORMULAS, THEN SUBSTITUTE VALUES AND UNITS. No credit will be given for numbers that appear without justification. Unless otherwise stated in a problem, provide 3 significant digits in answers. Read the entire quiz before answering any questions. Also it may be easier to answer parts of questions out of order.

### I. The 555 Timer in Astable Multivibrator Configuration (20 points)

Shown below is a 555-Timer configured as an astable multivibrator, which generates a train of voltage pulses.

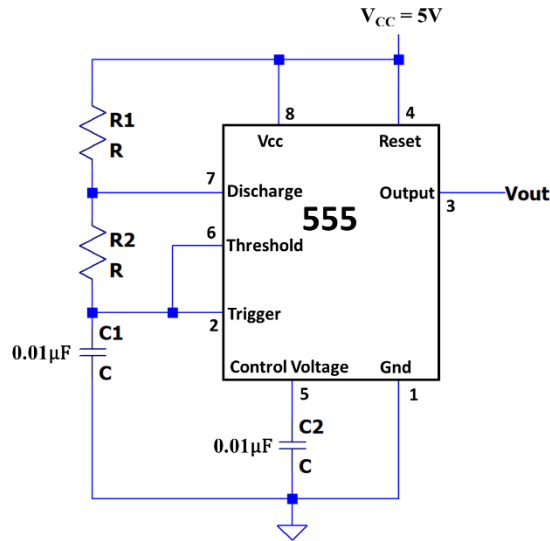

- (4 pts) You are tasked with using the 555-Timer to generate a train of voltage pulses with a frequency of  $f = 100 \text{ kHz}$  and a duty cycle of 75%. Calculate the total period of one cycle of pulses ( $T$ ), the amount of time per cycle that the voltage output is high ( $T_{high}$ ) and the amount of time per cycle that the voltage output is low ( $T_{low}$ ).



5. (2 pts) The astable multivibrator configuration of the 555 timer switches its output from high to low when  $V_{\text{threshold}}$  crosses  $2/3V_{cc}$  and from low to high when  $V_{\text{trigger}}$  crosses  $1/3V_{cc}$ , as shown below:

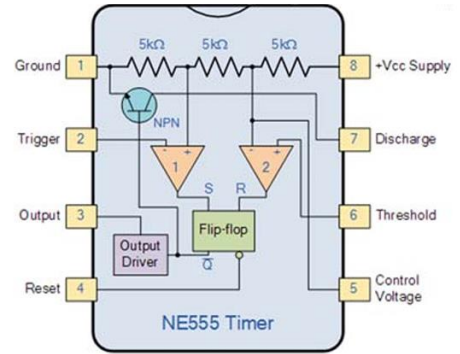
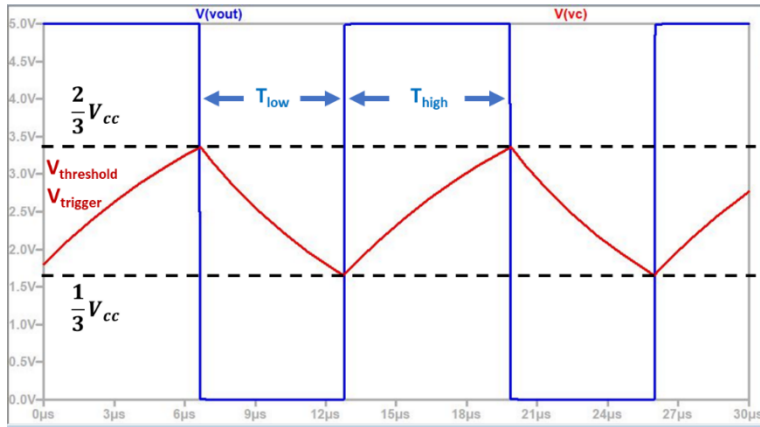

<https://commons.wikimedia.org/wiki/File:Ne555.gi>

Why is  $T_{\text{high}}$  determined by  $(R_1+R_2)C_1$ , but  $T_{\text{low}}$  is determined by  $R_2C_1$ ?

**II. Combinational and Sequential Digital Logic (20 points)**

1. (6 pts) Write the truth table for the following logic circuit, including entries for  $Q_{AB}$ ,  $Q_C$  and  $Q$ .

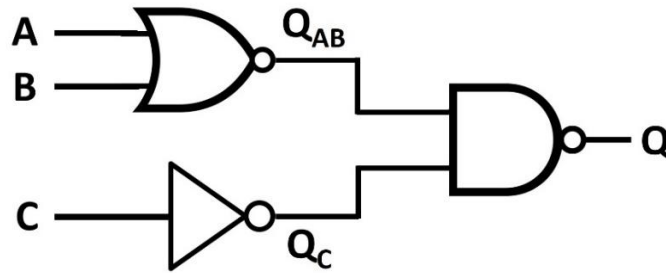

2. (2 pts) Which fundamental 3-input logic gate is the circuit in part 1 equivalent to? Explain your reasoning in one sentence.

3. (6 pts) JK Flip Flop: below is the timing diagram for a JK flip-flop with the inputs **CLK**, **J** and **K** already given. Sketch **Q** and  $\bar{Q}$  vs. time and fill out the table for **Q** and  $\bar{Q}$  at the given times.

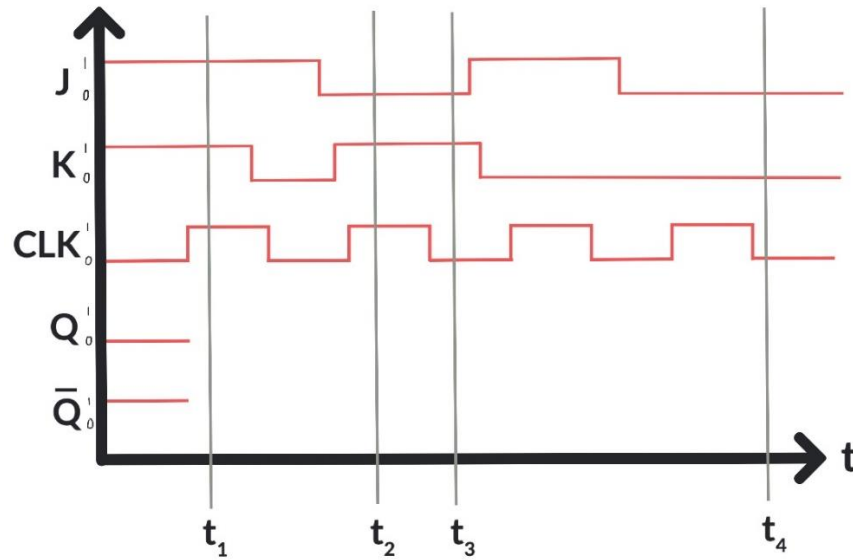

Time	J	K	Q	$\bar{Q}$
$t_1$				
$t_2$				
$t_3$				
$t_4$				

4. (4 pts) Counter: The counter circuit below consists of two D flip-flops (**Fa** and **Fb**), with a clock input **CLK\_A** and two outputs **Qa** and **Qb**. The D flip-flop is a *rising edge device* with the following truth table:

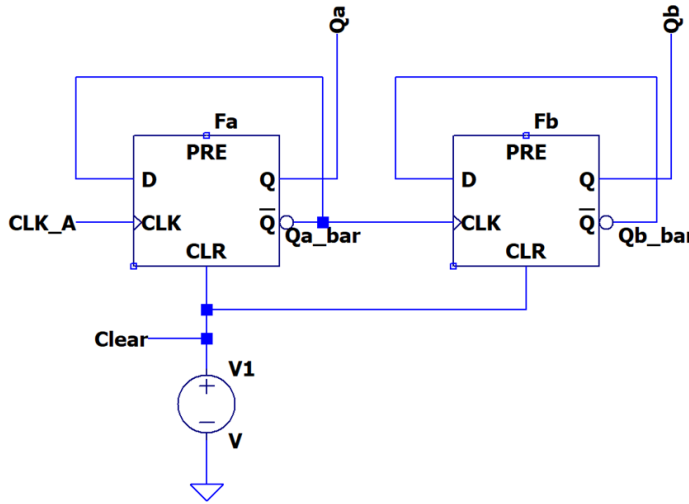

D	CLK	Q	$\bar{Q}$
0	Rising edge	0	1
1	Rising edge	1	0

Complete the timing diagram below by sketching the outputs  $Q_b$  and  $\bar{Q}_b$  ( $Qb\_bar$ ).

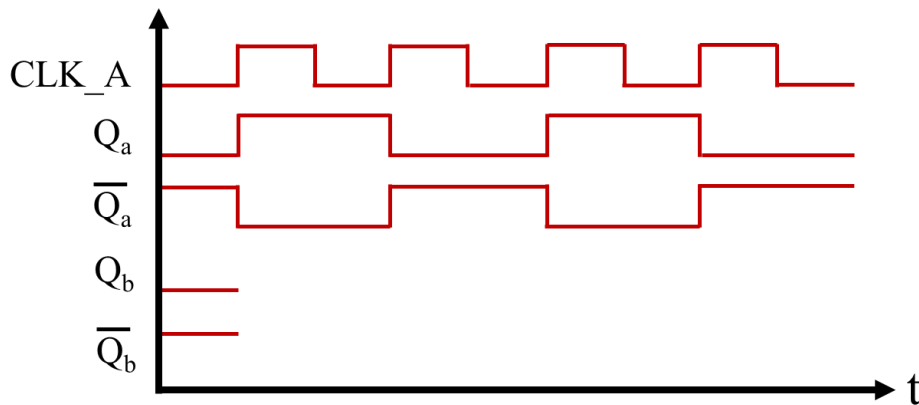

5. (2 pts) If a 3<sup>rd</sup>, 4<sup>th</sup>, and 5<sup>th</sup> D flip-flop (**Fc**, **Fd** and **Fe**) were to be added to the counter circuit in part 4 beyond **Fb** to provide additional outputs **Qc**, **Qd** and **Qe** to the circuit as shown below, what is the highest number this counter could represent? Give your answer in both binary (base 2) and decimal (base 10) representations.

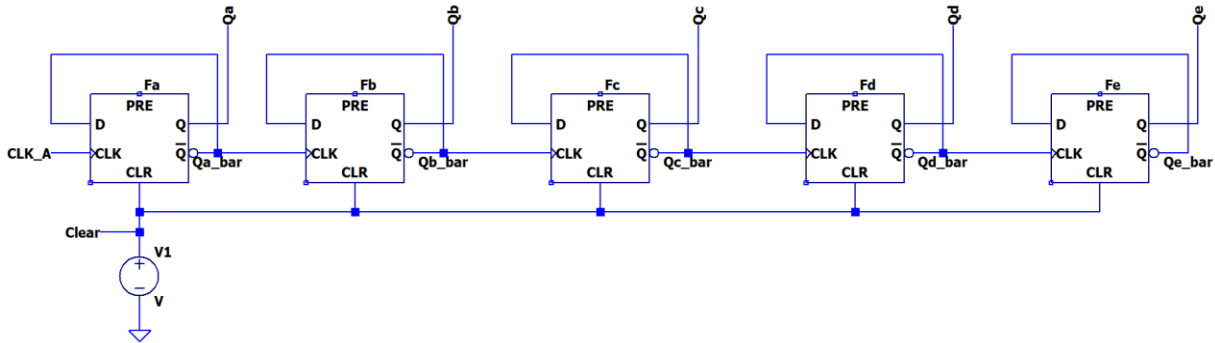



### III. Comparators and Schmitt Triggers (20 points)

The circuit shown is used for this problem.  $V_1$ ,  $V_2$  and  $V_3$  are DC voltage sources with the values shown.  $V_1=5V$ ,  $V_2=5V$  (resulting in  $-5V$  at the  $V^-$  input) and  $V_3=1V$ . Assume the output of the op-amp is capable of reaching the power supply voltages; hence it is what is called a **rail-to-rail op amp**.

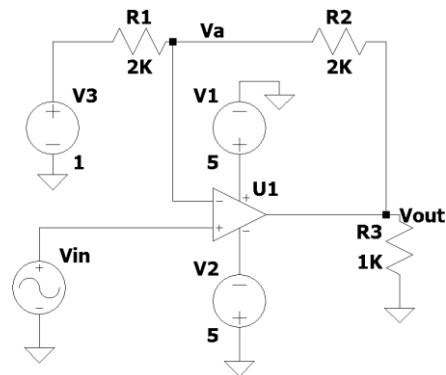

- (2 pts) What are the two possible values of  $V_{out}$ ?
- (4 pts) What are the two possible values of  $V_a$ , the voltage at the inverting node of the op amp?
- (8 pts) Plot  $V_{in}$  vs  $V_{out}$  on the graph shown. Label critical voltages.





#### IV. Diodes (20 points)

1. (4 pts) The graph shows  $V_1(t)$  for the circuit shown. Draw  $V_{out}(t)$  on the graph using the  $V_{on}$  Model with  $V_{on}=0.5V$ .  
**Label important voltages.**

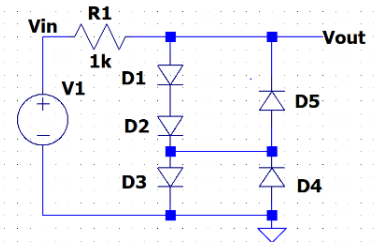
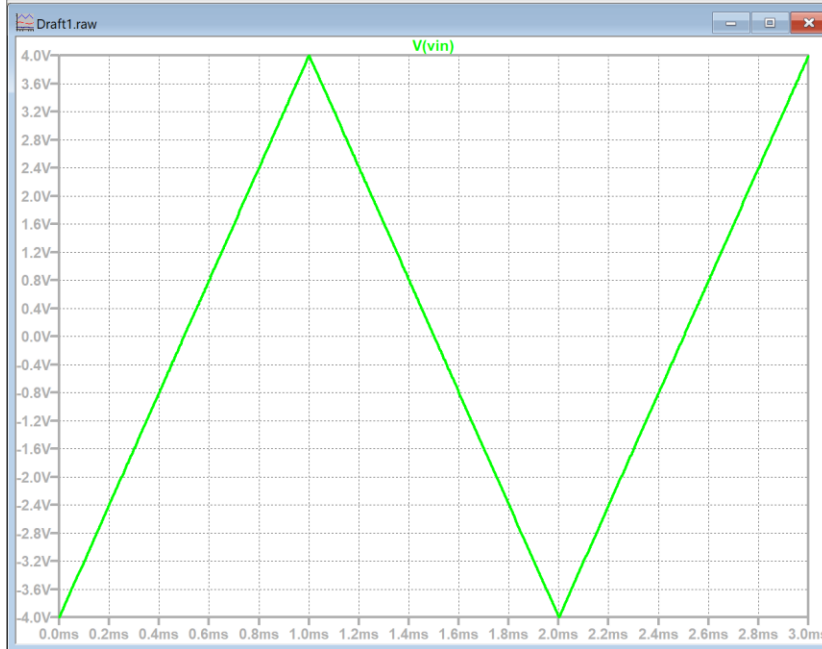

2. (2 pts) A diode is found to have  $I_S=4 \times 10^{-11} A$ . Find  $V_D$ , the diode voltage when  $I_D=200mA$  at room temperature and if  $n=1$ . Use the diode equation. Hint: assume that the  $-1$  term is insignificant when solving for  $V_D$  but then go back and show if it was appropriate to make that assumption about the “ $-1$ ” term.
3. (2 pts) Calculate the power flowing through the diode in part 2.

4. (3 pts) Rectifier diodes: For the circuit shown, R1 is the load and the voltage across R1 is  $V_{out}$ . Use the Von diode model with  $V_d=0.5V$ . Sketch  $V_{out}$ .  $V_1$  is already plotted.

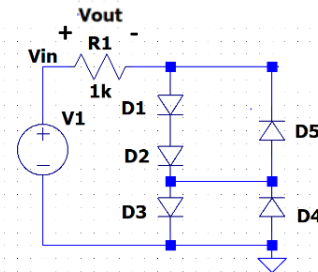
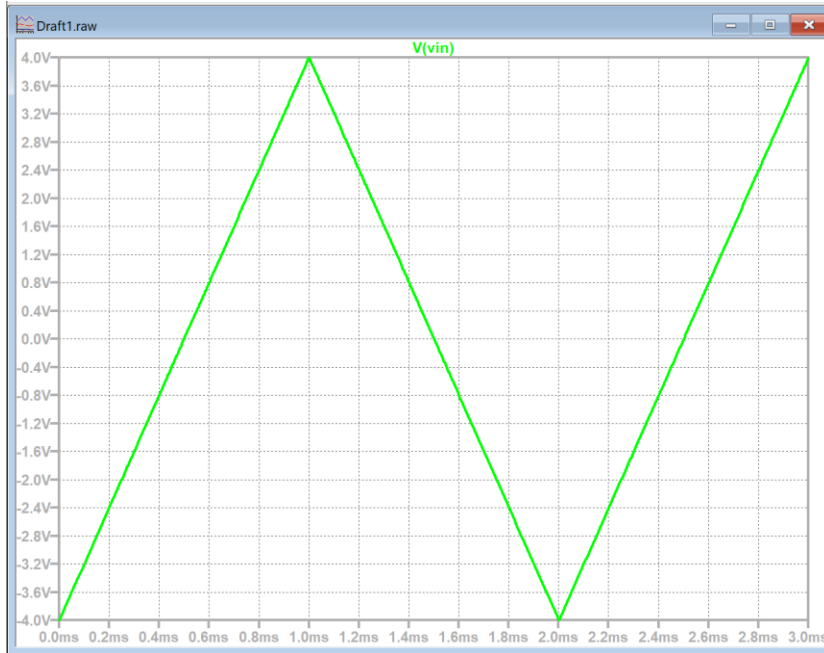

5. (2 pts) Describe in your own words how the behavior of Zener diodes is different from that of other diodes.

6. (3 pts) In the diagram at right, is there some voltage  $V_{in}$  that will cause current to flow in R1? Explain why or why not.

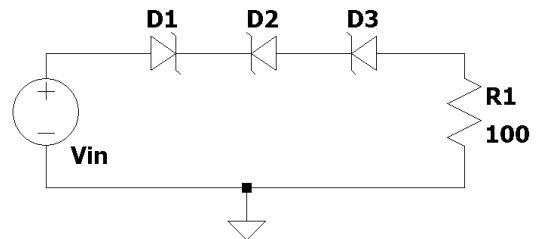

7. (2 pts) Suppose that another student has built the following circuit from Experiment 8.

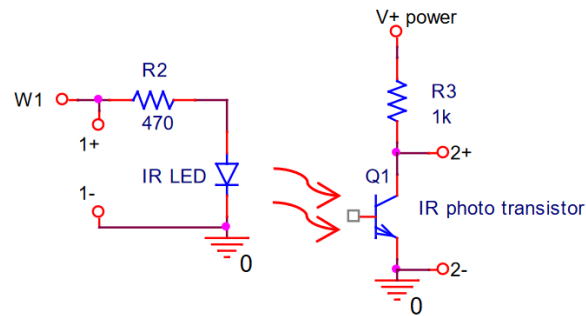

The student shows you an input and output waveform and claims that the output waveform represents the phototransistor responding to the IR LED. Describe one way you can verify that this is true without modifying the circuit.

8. (2 pts) In addition to being used to generate light, can light-emitting diodes also be used to build rectifier circuits? Explain why or why not.