

Questions on Basic Circuit Analysis

These should help prepare you for question 1 of quiz 1

*Fall 2004*

**1. Resistive Circuits (25 points)**

The circuit below is used to divide up a DC voltage for a digital to analog converter. Assume that  $R_1=1\text{K}$  ohms,  $R_2=2\text{K}$  ohms,  $R_3=1\text{K}$  ohms,  $R_4=2\text{K}$  ohms,  $R_5=1\text{k}$  ohms,  $R_6=1\text{k}$  ohms, and  $V_1 = 8$  volts.

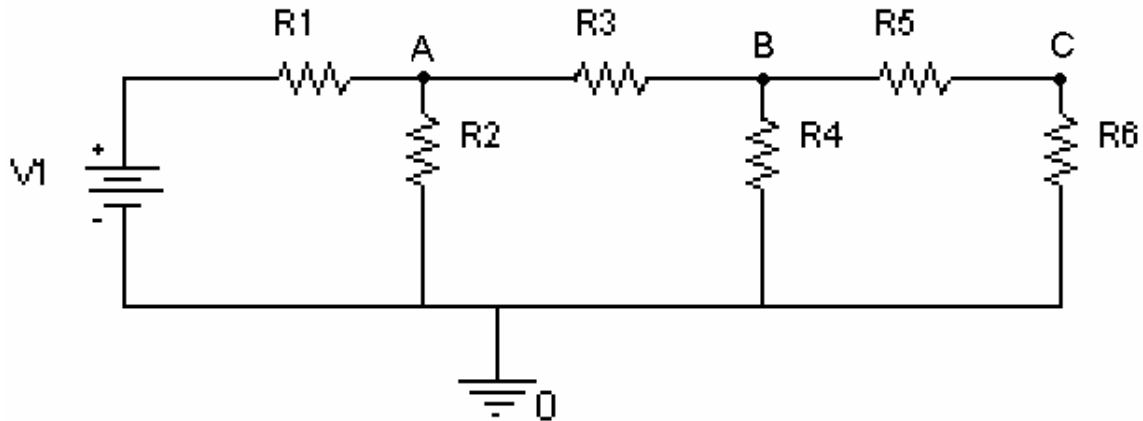

a) Find the combined resistance of the circuit with respect to  $V_1$ . (6 points)

b) Find the DC voltage at points A, B and C. (9 points)

c) Find the current through R1, R3 and R5. (6 points)

d) Label the colors of the bands in the following resistors:

R1 (1K) (2 points)

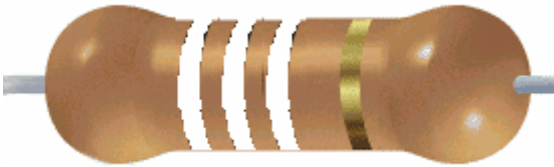

R2 (2K) (2 points)



Extra Credit: Why do you think the circuit is used to do digital to analog conversion. This would take a digital value (like 0110) and convert it to an analog voltage (6 volts)? (1 point)

*Fall 2004 solution*

*(none available)*

Spring 2004

1) Resistive Circuits (16 points)

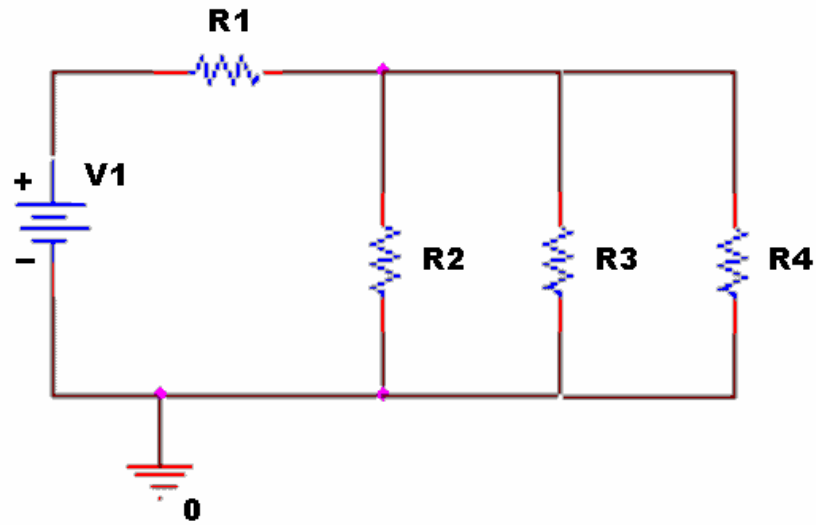

In the circuit above,  $V_1=5$  volts.  $R_1= 50\Omega$ ,  $R_2= 1000\Omega$ ,  $R_3= 2000\Omega$ ,  $R_4= 3000\Omega$

a) Find the voltage across  $R_1$ . (8 points)

b) Find the current through  $R_4$ . (8 points)

Spring 2004 solution

1) Resistive Circuits (16 points)

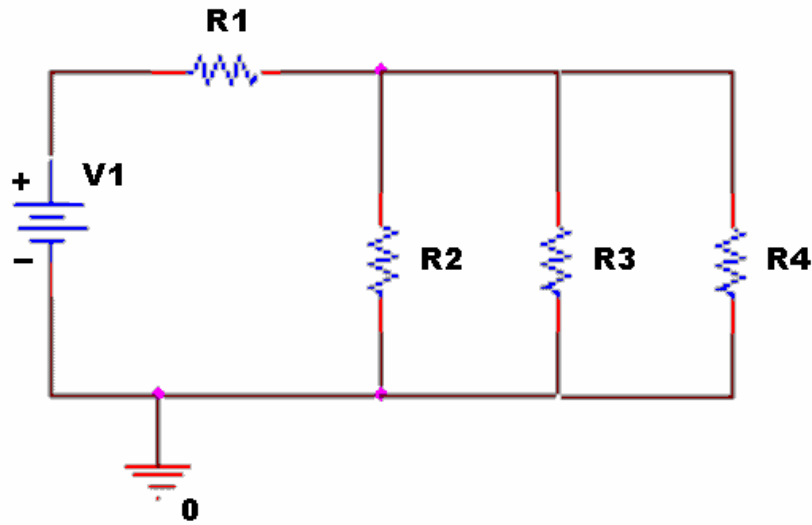

In the circuit above,  $V_1=5$  volts.  $R_1= 50\Omega$ ,  $R_2= 1000\Omega$ ,  $R_3= 2000\Omega$ ,  $R_4= 3000\Omega$

a) Find the voltage across  $R_1$ . (8 points)

$$1/(R_{234}) = 1/R_2 + 1/R_3 + 1/R_4 = 1/1K + 1/2K + 1/3K \quad R_{234}=545.5 \text{ ohms}$$

$$V_{R1} = (R_1/(R_1+R_{234}))V_1 = (50/(50+545.4))5 = 0.42V \quad \mathbf{V_{R1}=0.42V}$$

b) Find the current through  $R_4$ . (8 points)

$$V_{R4} = V_1 - V_{R1} = 5 - 0.42 = 4.58V$$

$$I_{R4} = V_{R4}/R_4 = 4.58/3000 = 1.53EE-3 \text{ amps} \quad \mathbf{I_{R4} = 1.53 \text{ mA}}$$

Fall 2003

**1. Resistive Circuits (20 points)**

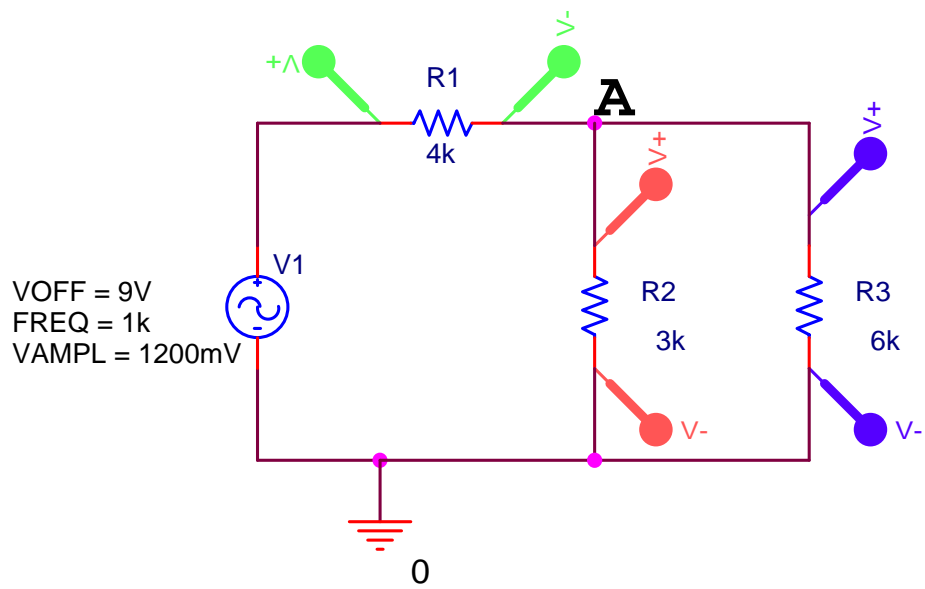

a) Given the circuit above, calculate the DC offset voltage at point A. (5 points)

b) For the same circuit, calculate the amplitude of the voltage at point A. (5 points)

c) What is the current through  $R_1$ ? (5 points)

d) Which of the following plots corresponds to the correct output for the circuit pictured above? (5 points)

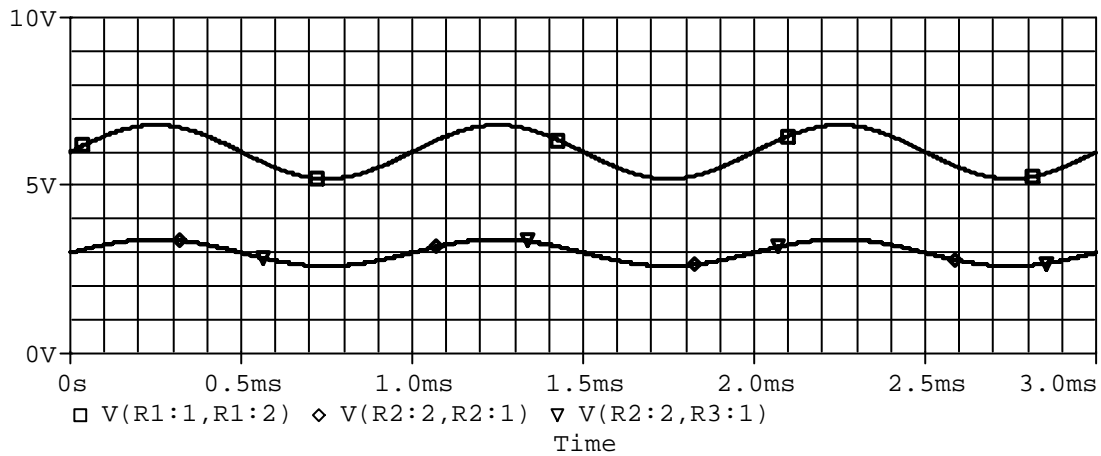
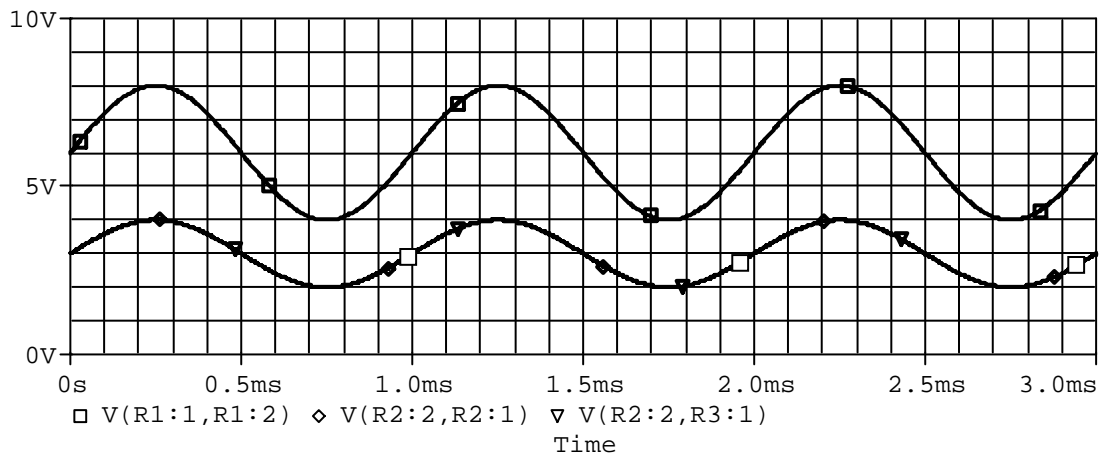
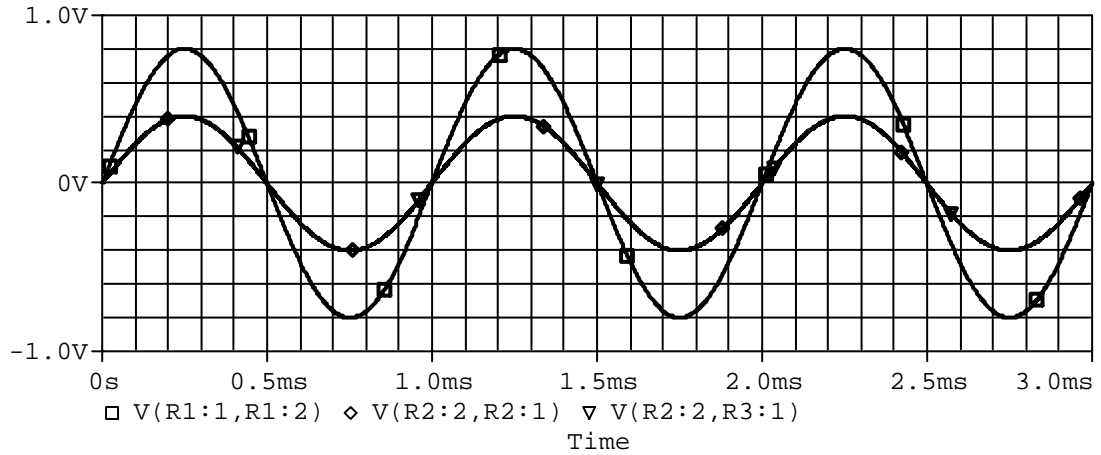

*Fall 2003 solution*

**1. Resistive Circuits (20 points)**

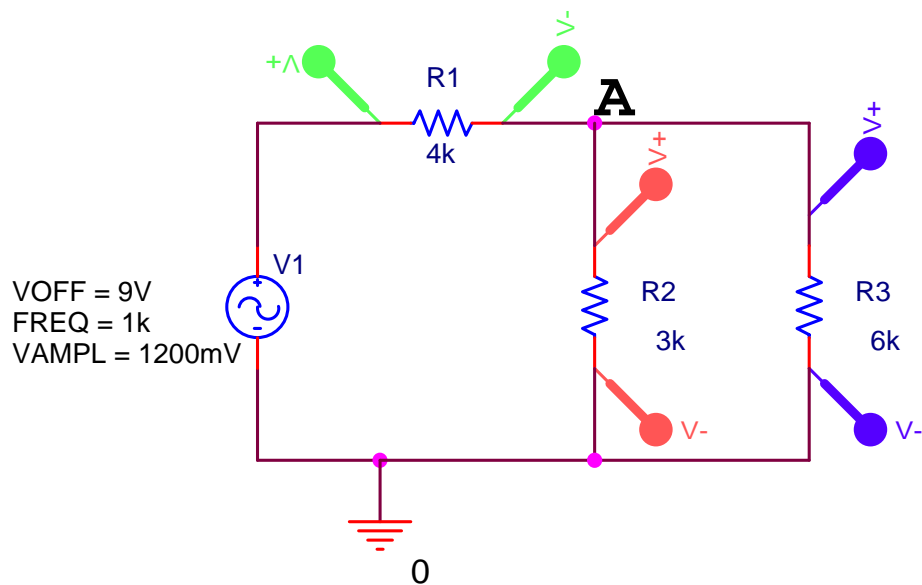

a) Given the circuit above, calculate the DC offset voltage at point A. (5 points)

$$V_{OFF} = 9V \quad R_{23} = R_2 // R_3 = \frac{3K * 6K}{3K + 2K} = 2K \text{ ohms}$$

$$V_A = 9V * \frac{2K}{2K + 4K} = 9/3 = 3V$$

**DC Offset at A is 3V**

b) For the same circuit, calculate the amplitude of the voltage at point A. (5 points)

$$V_{AMPL} = 1200mV = 1.2V$$

$$A_{AMPL} = 1.2(2K)/(2K + 4K) = 1.2/3 = 0.4V$$

**Amplitude at A is 0.4 V or 400mV**

c) What is the current through R1? (5 points)

*The current through R1 is a sinusoid. We know  $V=IR$ . We also know  $V(t)=I(t)R$ . If we write this in terms of the sine function,*

$$V_{DC_{R1}} + V_{AC_{R1}} \sin(\omega t) = [I_{DC_{R1}} + I_{AC_{R1}} \sin(\omega t)] * R_1 \text{ where } \omega = 2\pi f = 2K\pi$$

$$V_{DC_{R1}} = V_{OFF} \frac{4K}{2K + 4K} = 9 * 2/3 = 6V \text{ (or read off plot on next page)}$$

$$V_{AC_{R1}} = V_{AMPL} \frac{4K}{4K + 2K} = 1.2 * 2/3 = 0.8V \text{ (or read off plot on next page)}$$

$$I_{DC_{R1}} = 6V/4K = 1.5mA \quad I_{AC_{R1}} = 0.8V/4K = 0.2mA$$

$$I_{R1}(t) = 0.2mA \sin(2K\pi t) + 1.5mA$$

**(You should get some partial credit for successfully finding  $I_{DC_{R1}}$  and  $I_{AC_{R1}}$ )**



d) Which of the following plots corresponds to the correct output for the circuit pictured above? (5 points)

The plot below has no DC offset, so it cannot be correct.

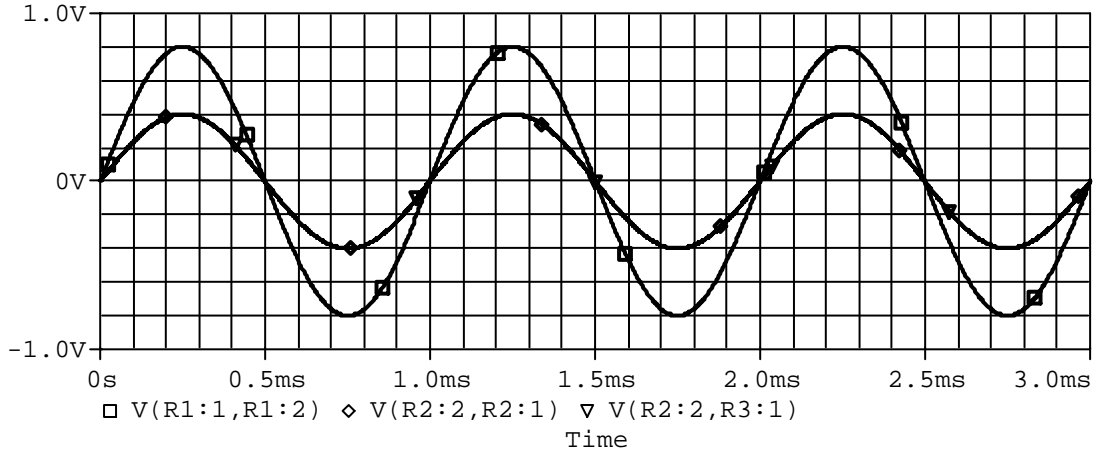

The plot below divides the DC offset correctly (6V and 3V), but the amplitudes are too big (2V and 1V)

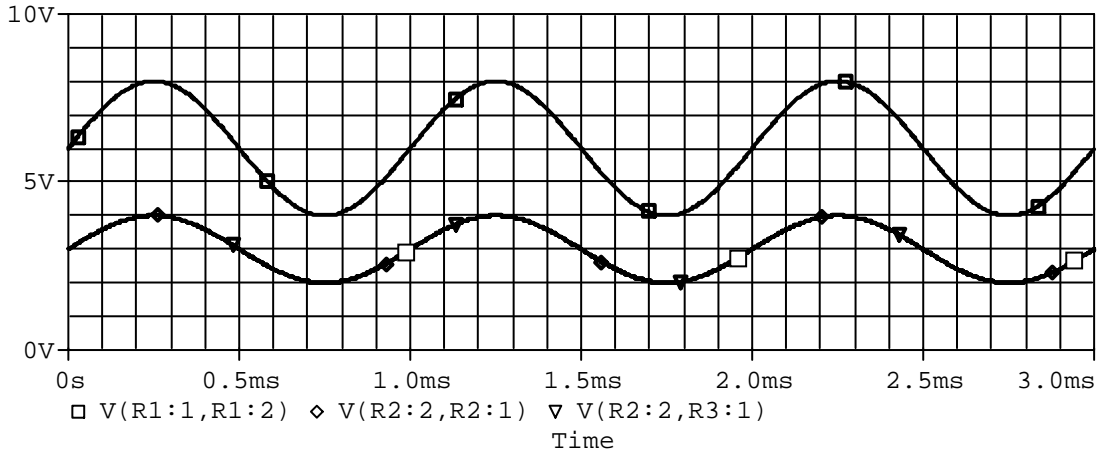

The plot below is correct. The DC voltage is 6V for R1 (square), and 3V for R2 and R3 (triangle and diamond). The amplitude across R1 is about 0.8V and over R2 and R3 is half that. The voltage across R2 and R3 must be the same because they are in parallel.

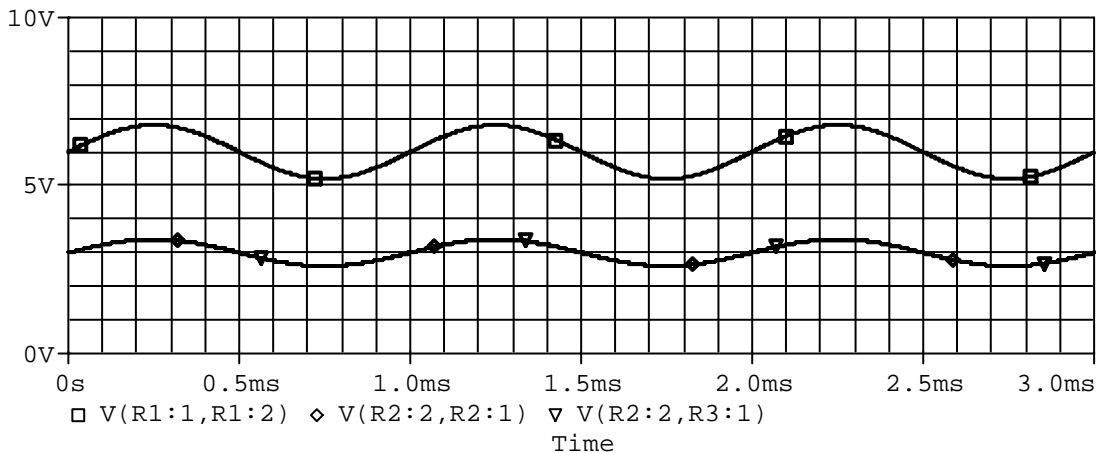

*Spring 2003*

**1. Resistive circuits (20 points)**

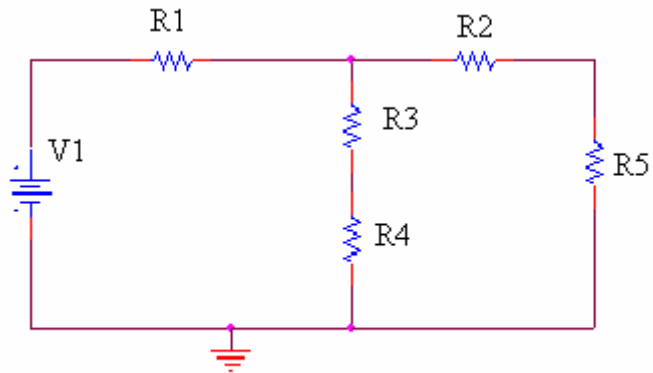

**Given:  $V_1=5$  volts.  $R_1= 50\Omega$ ,  $R_2= 3000\Omega$ ,  $R_3= 1000\Omega$ ,  $R_4= 550\Omega$ ,  $R_5=440\Omega$**

c) (8 points) Find the combined resistance of the circuit with respect to  $V_1$ .

b) (4 points) Find the voltage across  $R_1$ .

c) (8 points) Find the current through  $R_4$ .

*Spring 2003 solution*

**2. Resistive circuits (20 points)**

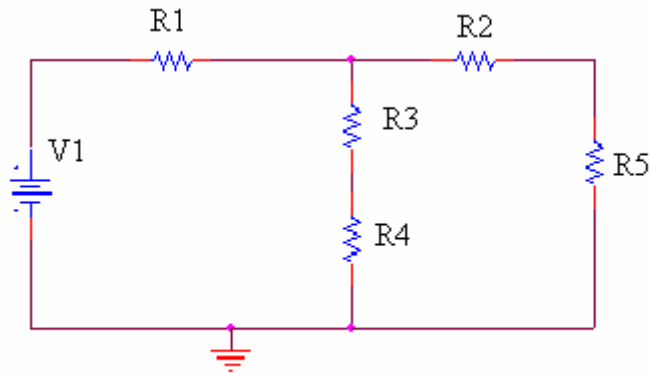

**Given:  $V1=5$  volts.  $R1= 50\Omega$ ,  $R2= 3000\Omega$ ,  $R3= 1000\Omega$ ,  $R4= 550\Omega$ ,  $R5=440\Omega$**

d) (8 points) Find the combined resistance of the circuit with respect to  $V1$ .

$$R_{25} = R2 + R5 = 3000 + 440 = 3440 \quad R_{34} = R3 + R4 = 1000 + 550 = 1550$$

$$R_{2345} = R_{25} \parallel R_{34} = (3440 \times 1550) / (3440 + 1550) = 1068.5$$

$$R_{12345} = 50 + 1068.5 = 1118.5$$

**$RT = 1120$  ohms (exactly 1118.5)**

b) (4 points) Find the voltage across  $R1$ .

$$VR1 = (V1)(R1) / (R1 + R_{1234}) = 5(50) / (1118.5) = 0.22 \text{ volts}$$

**$VR1 = 0.2$  volts**

c) (8 points) Find the current through  $R4$ .

$$V_{25} = V_{34} = V1 - VR1 = 5 - 0.22 = 4.78 \text{ volts}$$

$$I_{34} = I_4 = V_{34} / R_{34} = 4.78 / 1550 = 3.08 \text{ milliamps}$$

**$I_4 = 3.1$  milliamps**

$$\text{Check: } I_{25} = V_{25} / R_{25} = 4.78 / 3440 = 1.39 \text{ milliamps}$$

$$IR1 = V1 / RT = 5 / 1120 = 4.46 \text{ milliamps}$$

$$IR1 = I_{25} + I_{34} = 4.46 = 1.39 + 3.08 = 4.47 \text{ (close enough)}$$

Fall 2002

3. Resistive circuits (20 points)

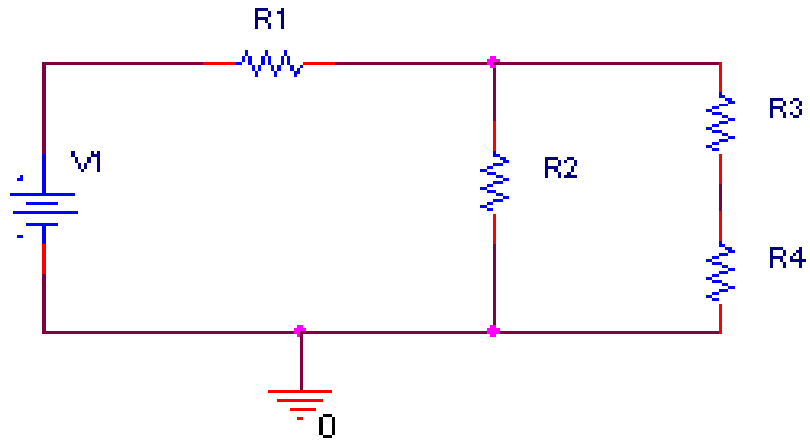

Given:  $V_1=5$  volts.  $R_1= 2000\Omega$ ,  $R_2= 1000\Omega$ ,  $R_3= 500\Omega$ ,  $R_4= 400\Omega$

e) (8 points) Find the total resistance of the circuit.

b) (6 points) Find the voltage across  $R_1$ .

c) (6 points) Find the current through  $R_4$ .

*Fall 2002 solution*

**1. Resistive circuits (20 points)**

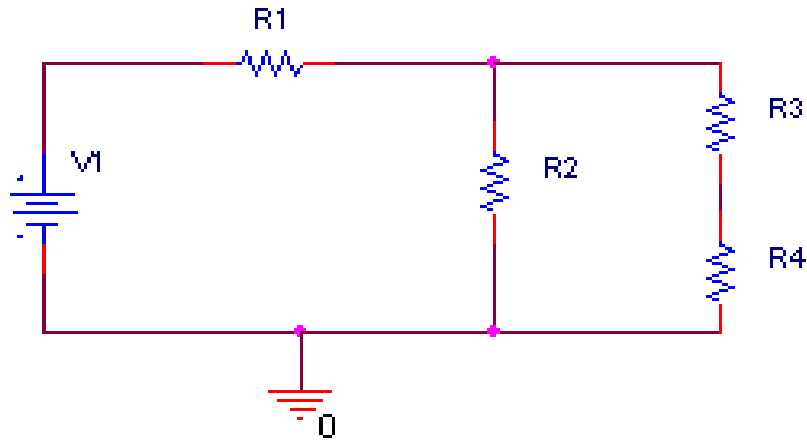

**Given:  $V_1=5$  volts.  $R_1= 2000\Omega$ ,  $R_2= 1000\Omega$ ,  $R_3= 500\Omega$ ,  $R_4= 400\Omega$**

f) (8 points) Find the total resistance of the circuit.

$$R_T = R_1 + R_2 // (R_3 + R_4)$$

$$(R_3 + R_4) = .5K + .4K = .9K$$

$$R_{234} = R_2 // (R_3 + R_4) = (1K * .9K) / (1K + .9K) = 0.474K$$

$$R_T = 2K + 0.474K = \mathbf{2.474 \text{ Kohms}}$$

b) (6 points) Find the voltage across  $R_1$ .

$$I_T = V_T / R_T = 5V / 2.474K = 2.02 \text{ mamps}$$

$$V_1 = I_T * R_1 = 2.02m * 2K = \mathbf{4.04 \text{ volts}}$$

c) (6 points) Find the current through  $R_4$ .

$$V_2 = V_T - V_1 = 5 - 4.04 = 0.96 \text{ volts}$$

$$I_2 = V_2 / R_2 = 0.96 / 1K = 0.96 \text{ mamps}$$

$$I_3 = I_4 = I_T - I_2 = 2.02m - 0.96m = \mathbf{1.06 \text{ mamps}}$$

Spring 2002

4. Resistive circuits (20 points)

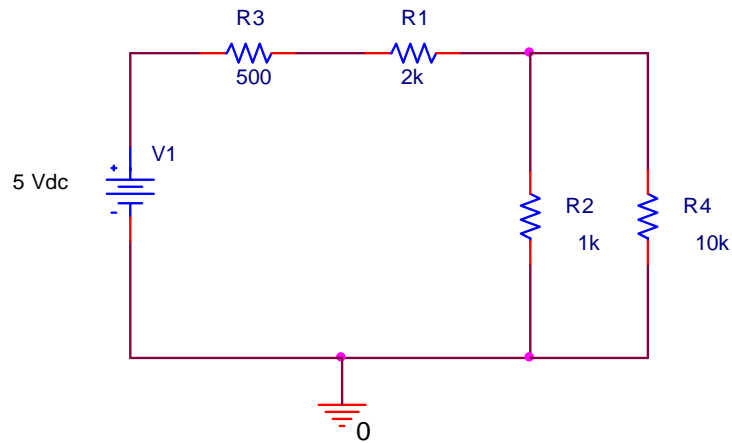

In the circuit above,  $V1=5$  volts.  $R1=2000\Omega$ ,  $R2=1000\Omega$ ,  $R3=500\Omega$ ,  $R4=10,000\Omega$

a) (10 points) Find the amplitude of the voltage across R1.

b) (10 points) Find the current through R4.

ENGR4300 Test 1A  
Spring 2002

Name answer key  
Section \_\_\_\_\_

1. Resistive circuits (20 points)

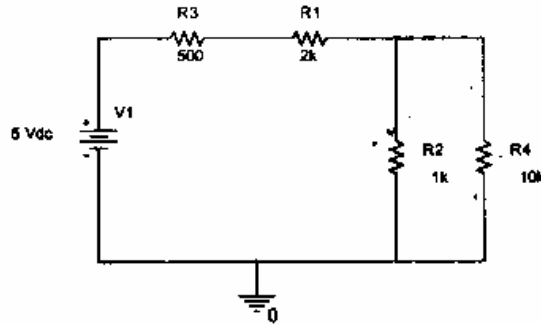

In the circuit above,  $V_1=5$  volts.  $R_1=2000\Omega$ ,  $R_2=1000\Omega$ ,  $R_3=500\Omega$ ,  $R_4=10,000\Omega$

a) (10 points) Find the amplitude of the voltage across  $R_1$ .

$$R_{24} = \frac{1k \cdot 10k}{1k + 10k} = .909 k\Omega$$

$$R_{eq} = R_3 + R_1 + R_{24} =$$

$$= 500 + 2000 + 909$$

$$= 3409 \Omega$$

$$I_T = \frac{V_T}{R_{eq}} = \frac{5}{3409} = 1.4667 \text{ mA}$$

$$V_1 = I_T R_1$$

$$= (1.4667 \text{ mA})(2k)$$

$$\boxed{V_1 = 2.9 \text{ V}}$$

b) (10 points) Find the current through  $R_4$ .

$$V_{24} = I_T R_{24} = (1.4667 \text{ mA})(.909k)$$

$$= 1.33 \text{ V}$$

$$V_4 = I_4 R_4$$

$$1.33 = I_4 (10,000)$$

$$\boxed{I_4 = .133 \text{ mA}}$$

1. Resistive circuits (20 points)

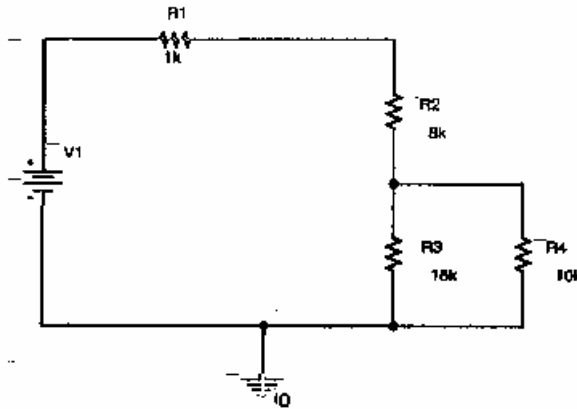

In the circuit above,  $V_1 = 15$  volts.

a) (10 points) Find the amplitude of the voltage across  $R_2$ .

$$R_{34} = R_3 \parallel R_4 = \frac{15k \cdot 10k}{15k + 10k} = \frac{150}{25} k\Omega = 6k\Omega$$



$$V_{R_2} = \frac{R_2}{R_1 + R_2 + R_{34}} V_1 = \frac{8k\Omega}{1k + 8k + 6k} \times 15V = 8V$$

b) (10 points) Find the current through  $R_4$ .

Hint: First find the voltage across the combination of  $R_3$  and  $R_4$ , then use the Ohm's law on  $R_4$ .

$$V_{R_{34}} = \frac{R_{34}}{R_1 + R_2 + R_{34}} V_1 = \frac{6k\Omega}{1k + 8k + 6k} \times 15V = 6V$$

$$V_{R_4} = V_{R_{34}}$$

$$I_{R_4} = \frac{V_{R_4}}{R_4} = \frac{6V}{10k\Omega} = 0.6 \text{ mA}$$



**Fall 2000**

**1. Resistance Calculations (20 Points)**

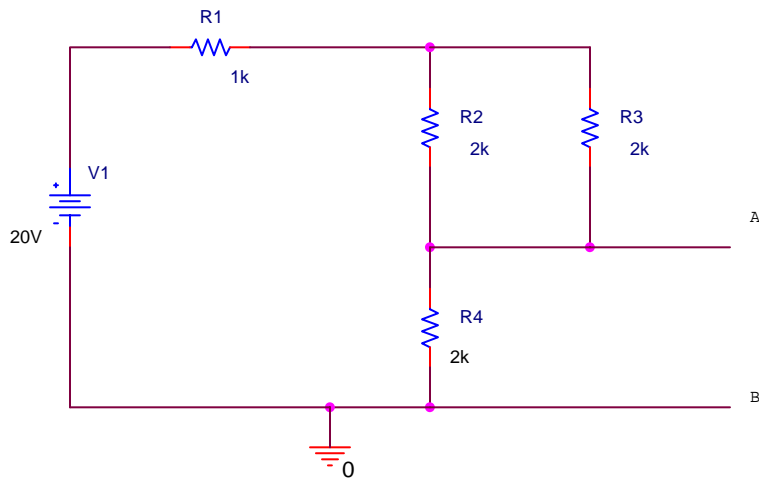

In the circuit above, determine the voltage between the two points marked A and B.

You have just found the Thevenin voltage  $V_{th}$  for this configuration  $V_{TH}$ . Now find the Thevenin equivalent resistance  $R_{th}$ . Be careful, the source leg in the circuit has finite resistance.

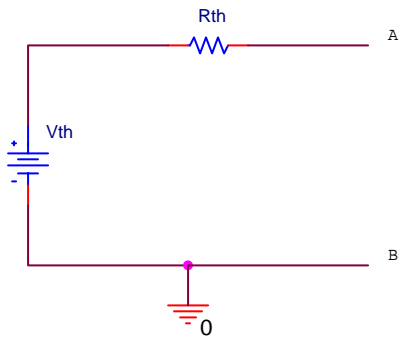

*Fall 2000 solution*  
*(none available)*