

Electronic Instrumentation

Experiment 4

- * Part A: Introduction to Operational Amplifiers
- * Part B: Voltage Followers
- * Part C: Integrators and Differentiators
- * Part D: Amplifying the Strain Gauge Signal

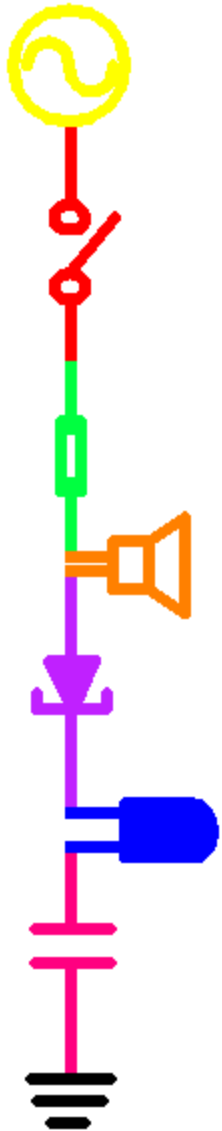

Part A

Introduction to Operational Amplifiers

- ◆ Operational Amplifiers
- ◆ Op-Amp Circuits
 - The Inverting Amplifier
 - The Non-Inverting Amplifier

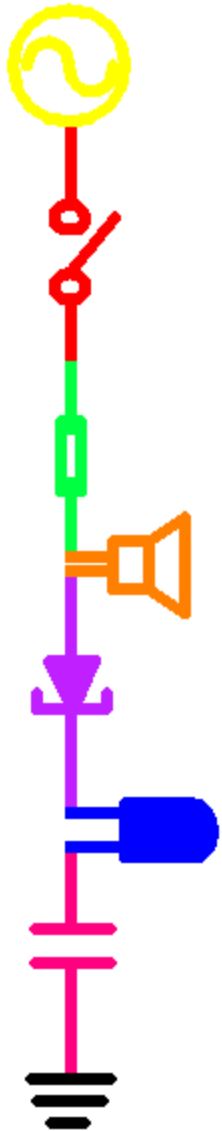

Operational Amplifiers

- ◆ Op-Amps are possibly the most versatile linear integrated circuits used in analog electronics.
- ◆ The Op-Amp is not strictly an element; it contains elements, such as resistors and transistors.
- ◆ However, it is a **basic building block**, just like R, L, and C.
- ◆ We treat this complex circuit as a **black box**.

The Op-Amp Chip

- ◆ The op-amp is a chip, a small black box with 8 connectors or pins (only 5 are usually used).
- ◆ The pins in any chip are numbered from 1 (starting at the upper left of the indent or dot) around in a U to the highest pin (in this case 8).

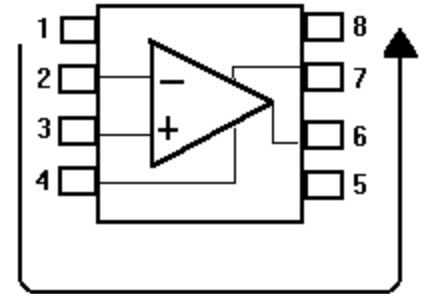
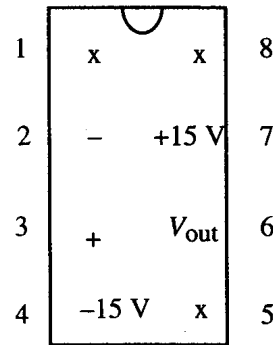
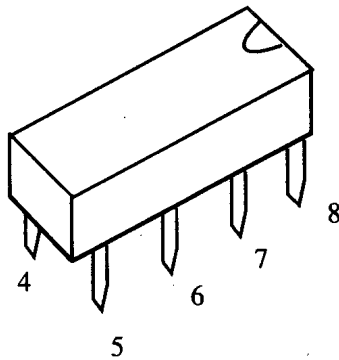
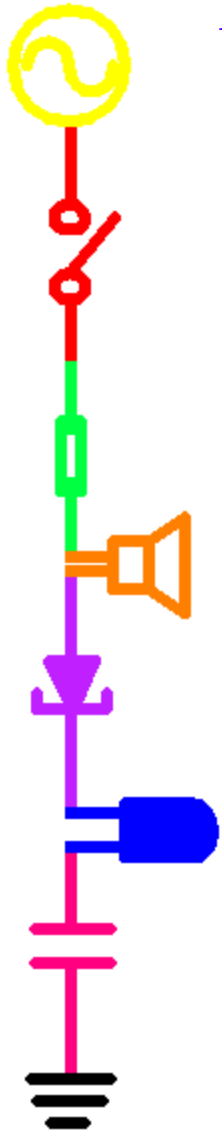

741 Op Amp or LM351 Op Amp

Op-Amp Input and Output

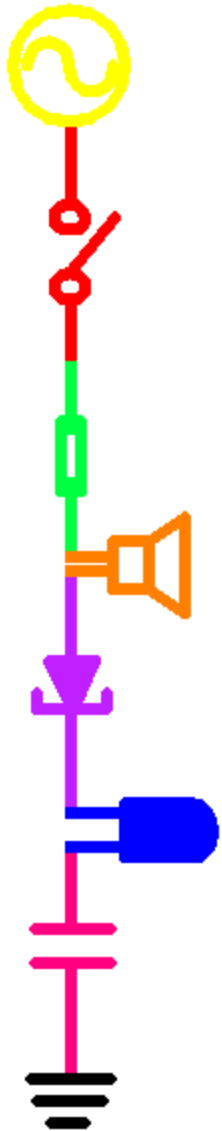

- ◆ The op-amp has two inputs, an inverting input (-) and a non-inverting input (+), and one output.
- ◆ The output goes positive when the non-inverting input (+) goes more positive than the inverting (-) input, and vice versa.
- ◆ The symbols + and - do not mean that that you have to keep one positive with respect to the other; they tell you the relative phase of the output.

$$(V_{in} = V_1 - V_2)$$

A fraction of a millivolt between the input terminals will swing the output over its full range.

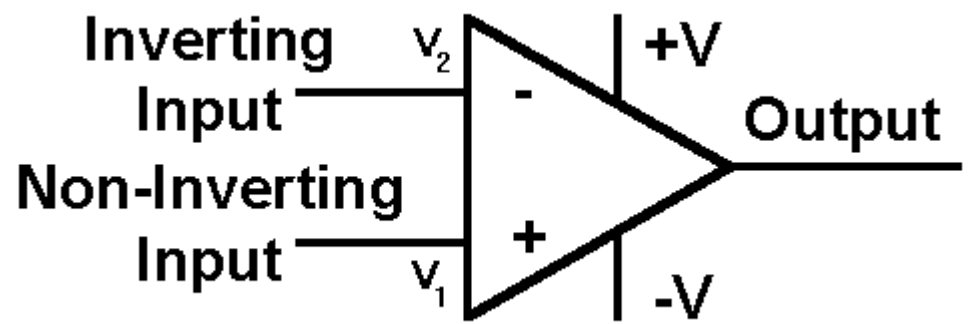

Powering the Op-Amp

- ◆ Since op-amps are used as amplifiers, they need an external source of (constant DC) power.
- ◆ Typically, this source will supply +15V at +V and -15V at -V. We will use $\pm 9V$. The op-amp will output a voltage range of of somewhat less because of internal losses.

The power supplied determines the output range of the op-amp. It can never output more than you put in. Here the maximum range is about 28 volts. We will use $\pm 9V$ for the supply, so the maximum output range is about 16V.

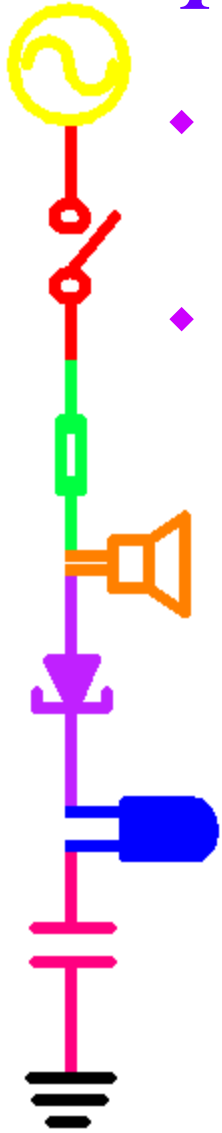
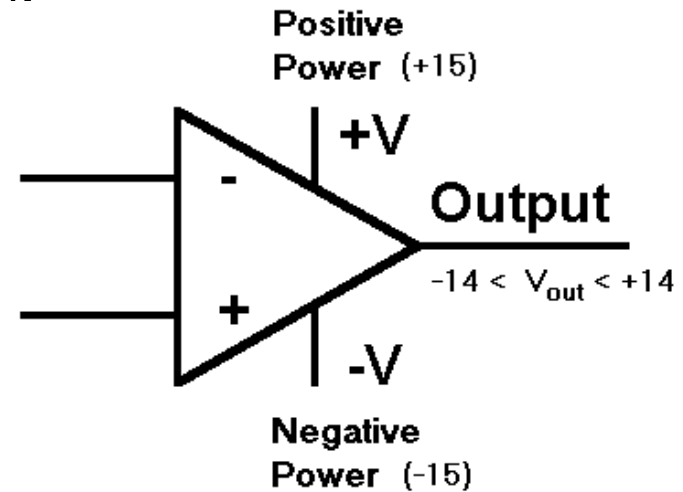

Op-Amp Intrinsic Gain

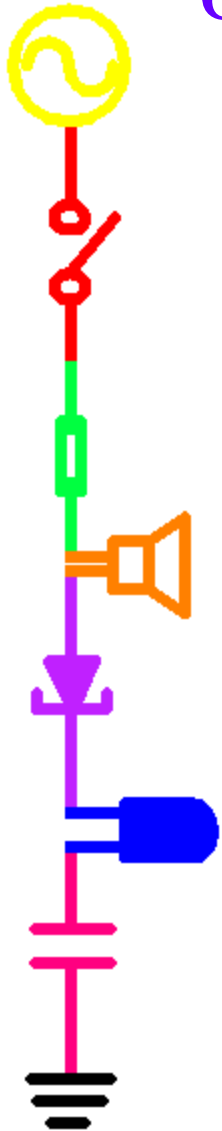

- ◆ Amplifiers increase the magnitude of a signal by multiplier called a gain -- “A”.
- ◆ The internal gain of an op-amp is very high. The exact gain is often unpredictable.
- ◆ We call this gain the *open-loop gain* or *intrinsic gain*.

$$\frac{V_{\text{out}}}{V_{\text{in}}} = A_{\text{open loop}} \approx 10^5 - 10^6$$

- ◆ The output of the op-amp is this gain multiplied by the input

$$V_{\text{out}} = A_{\text{ol}} \cdot V_{\text{in}} = A_{\text{ol}} (V_1 - V_2)$$

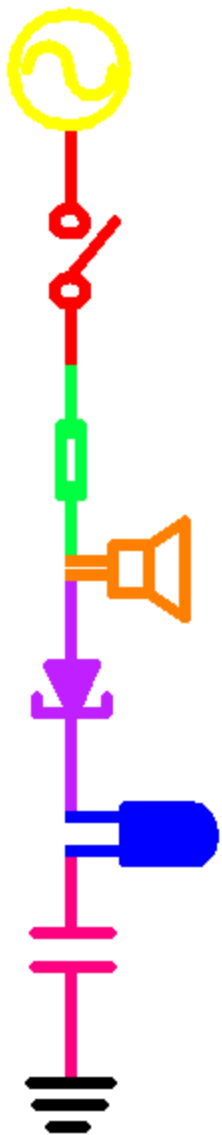

Op-Amp Saturation

- ◆ The huge gain causes the output to change dramatically when $(V_1 - V_2)$ changes sign.
- ◆ However, the op-amp output is limited by the voltage that you provide to it.
- ◆ When the op-amp is at the maximum or minimum extreme, it is said to be *saturated*.

$$-V \leq V_{out} \leq +V$$

if $V_1 > V_2$ then $V_{out} \approx +V$ positive saturation

if $V_1 < V_2$ then $V_{out} \approx -V$ negative saturation

How can we keep it from saturating?

Feedback

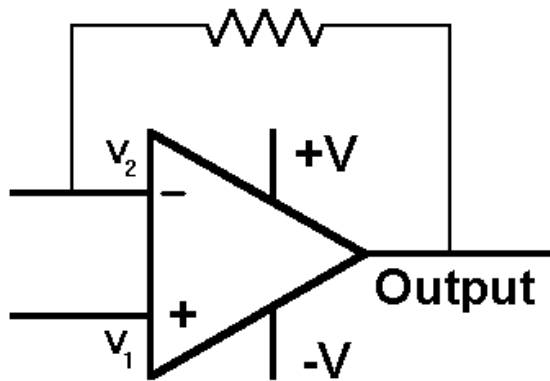

Negative Feedback

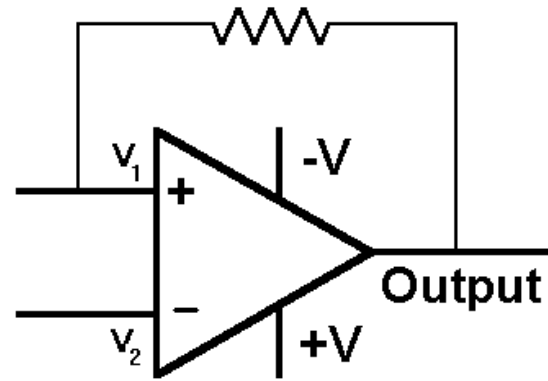

Positive Feedback

- ◆ Negative Feedback

- As information is fed back, the output becomes more stable. Output tends to stay in the “linear” range. The linear range is when $V_{out}=A(V_1-V_2)$ vs. being in saturation.
- Examples: cruise control, heating/cooling systems

- ◆ Positive Feedback

- As information is fed back, the output destabilizes. The op-amp tends to saturate.
- Examples: Guitar feedback, stock market crash
- Positive feedback was used before high gain circuits became available.

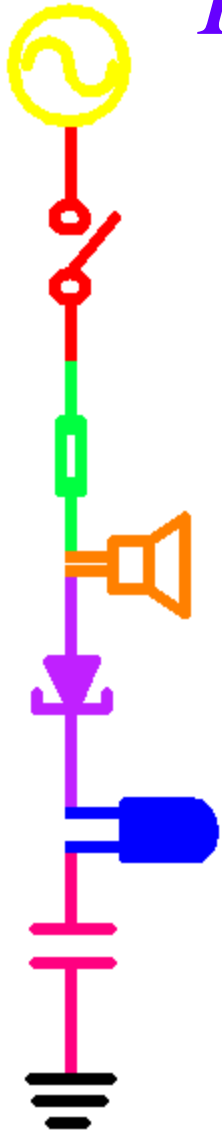



Op-Amp Circuits use Negative Feedback

- ◆ Negative feedback couples the output back in such a way as to cancel some of the input.
- ◆ Amplifiers with negative feedback depend less and less on the open-loop gain and finally depend only on the properties of the values of the components in the feedback network.
- ◆ The system gives up excessive gain to improve predictability and reliability.



Op-Amp Circuits

- ◆ Op-Amps circuits can perform mathematical operations on input signals:
 - addition and subtraction
 - multiplication and division
 - differentiation and integration
- ◆ Other common uses include:
 - Impedance buffering
 - Active filters
 - Active controllers
 - Analog-digital interfacing



Typical Op Amp Circuit

- V+ and V- power the op-amp
- Vin is the input voltage signal
- R2 is the feedback impedance
- R1 is the input impedance
- Rload is the load

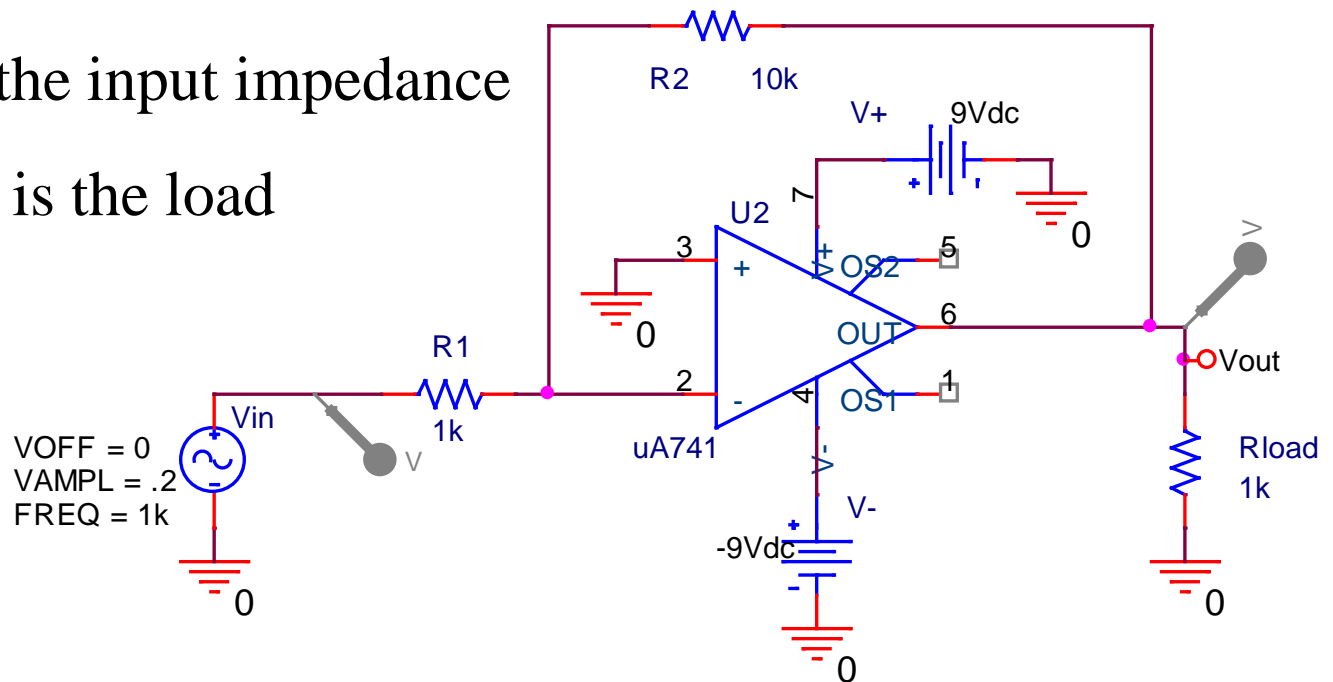

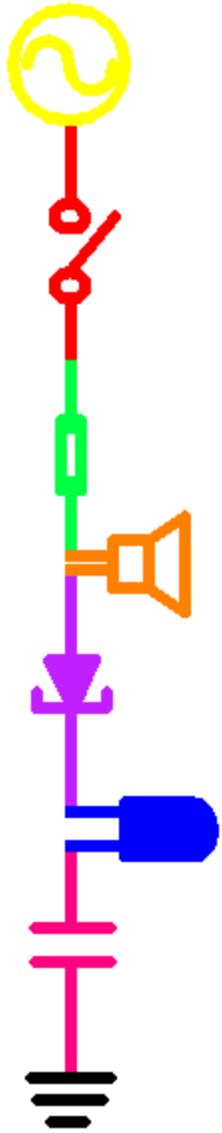

The Inverting Amplifier

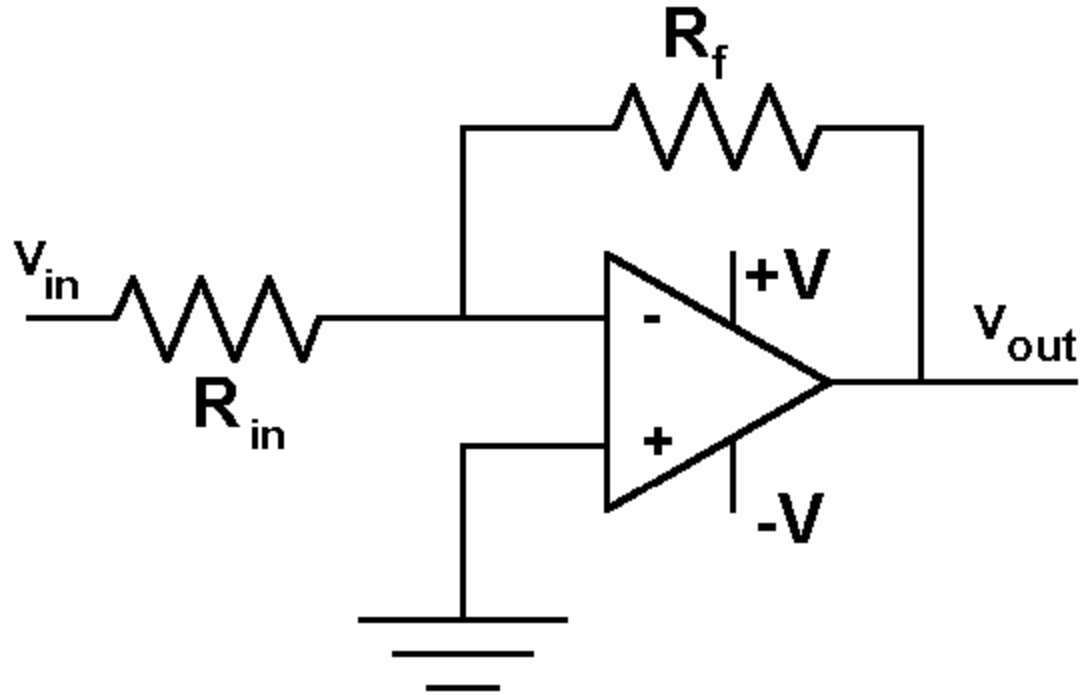

$$V_{out} = -\frac{R_f}{R_{in}} V_{in} \quad A = -\frac{R_f}{R_{in}}$$

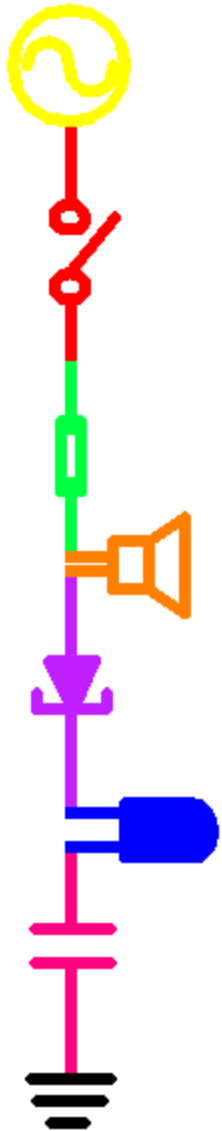

The Non-Inverting Amplifier

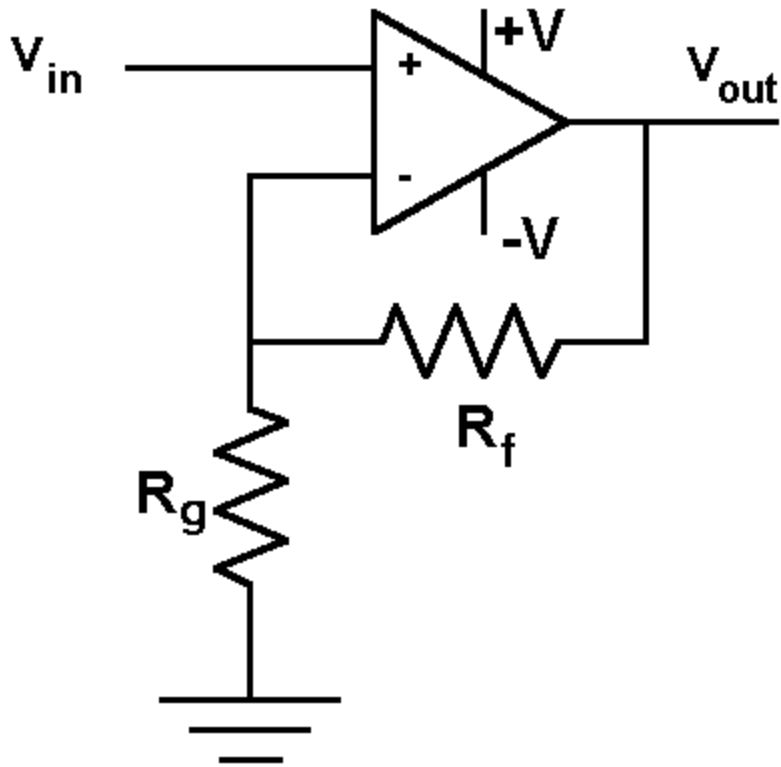

$$V_{out} = \left(1 + \frac{R_f}{R_g} \right) V_{in}$$

$$A = 1 + \frac{R_f}{R_g}$$

**Remember to disconnect the
batteries.**

End of part A

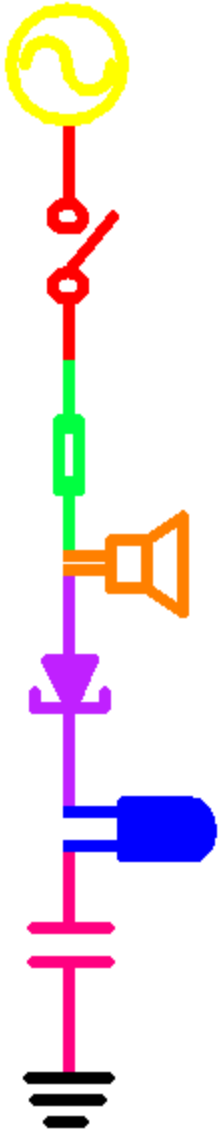

Part B

The Voltage Follower

- ◆ Op-Amp Analysis
- ◆ Voltage Followers

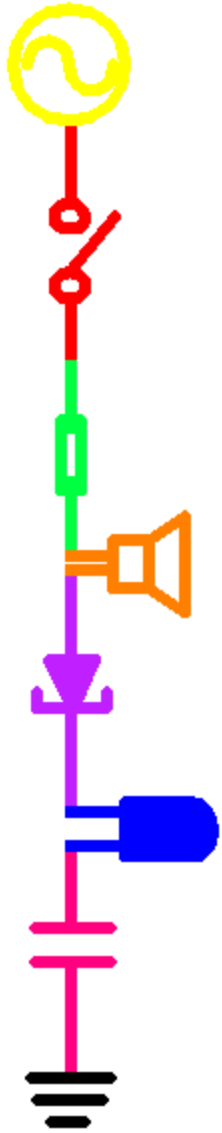



Op-Amp Analysis

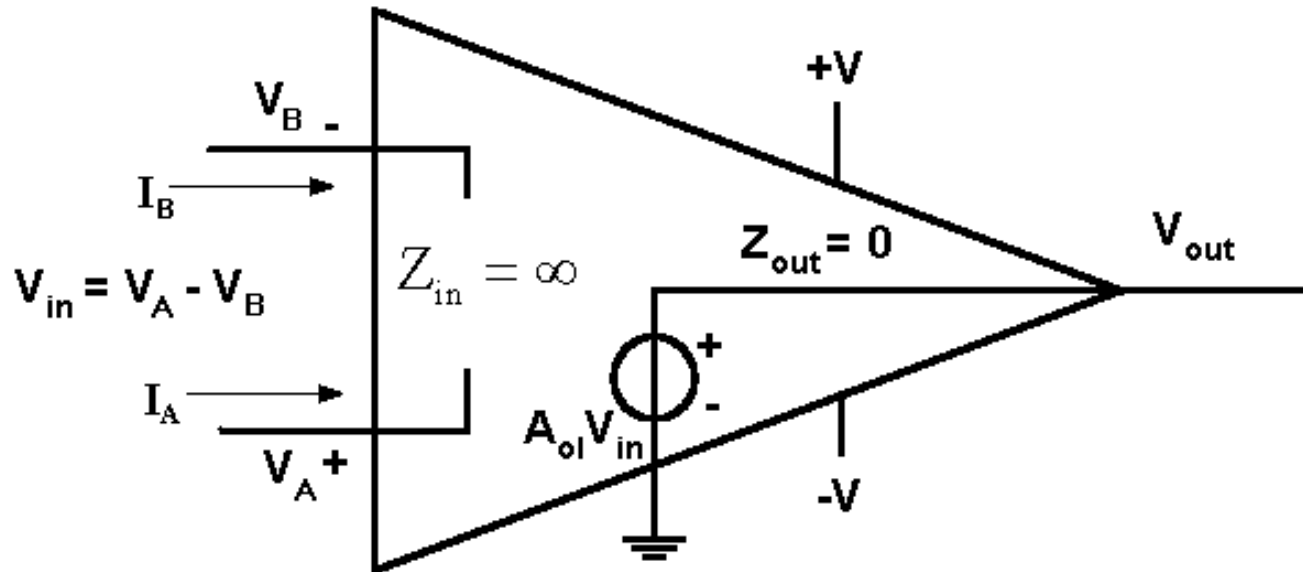

◆ We assume we have an ideal op-amp:

- infinite input impedance (no current at inputs)
- zero output impedance (no internal voltage losses)
- infinite intrinsic gain
- instantaneous time response

Golden Rules of Op-Amp Analysis

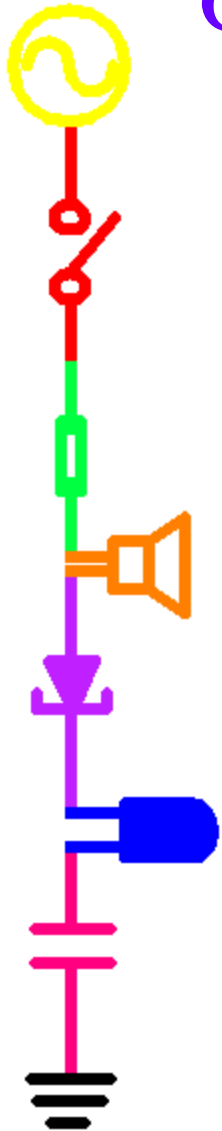

◆ Rule 1: $V_A = V_B$

- The output attempts to do whatever is necessary to make the voltage difference between the inputs zero.
- The op-amp “looks” at its input terminals and swings its output terminal around so that the external feedback network brings the input differential to zero.

◆ Rule 2: $I_A = I_B = 0$

- The inputs draw no current
- The inputs are connected to what is essentially an open circuit

Steps in Analyzing Op-Amp Circuits

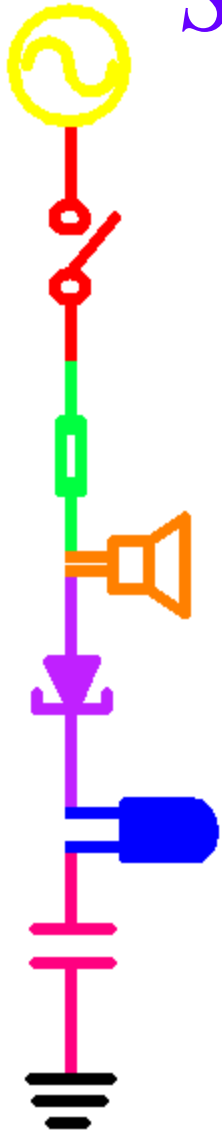

- 1) Remove the op-amp from the circuit and draw two circuits (one for the + and one for the – input terminals of the op amp).
- 2) Write equations for the two circuits.
- 3) Simplify the equations using the rules for op amp analysis and solve for V_{out}/V_{in}

Why can the op-amp be removed from the circuit?

- *There is no input current, so the connections at the inputs are open circuits.*
- *The output acts like a new source. We can replace it by a source with a voltage equal to V_{out} .*

Analyzing the Inverting Amplifier

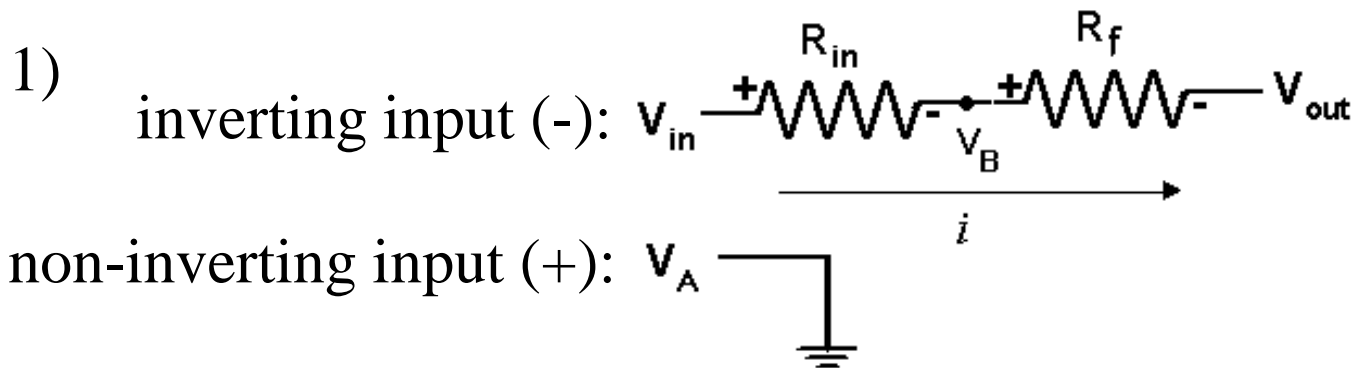
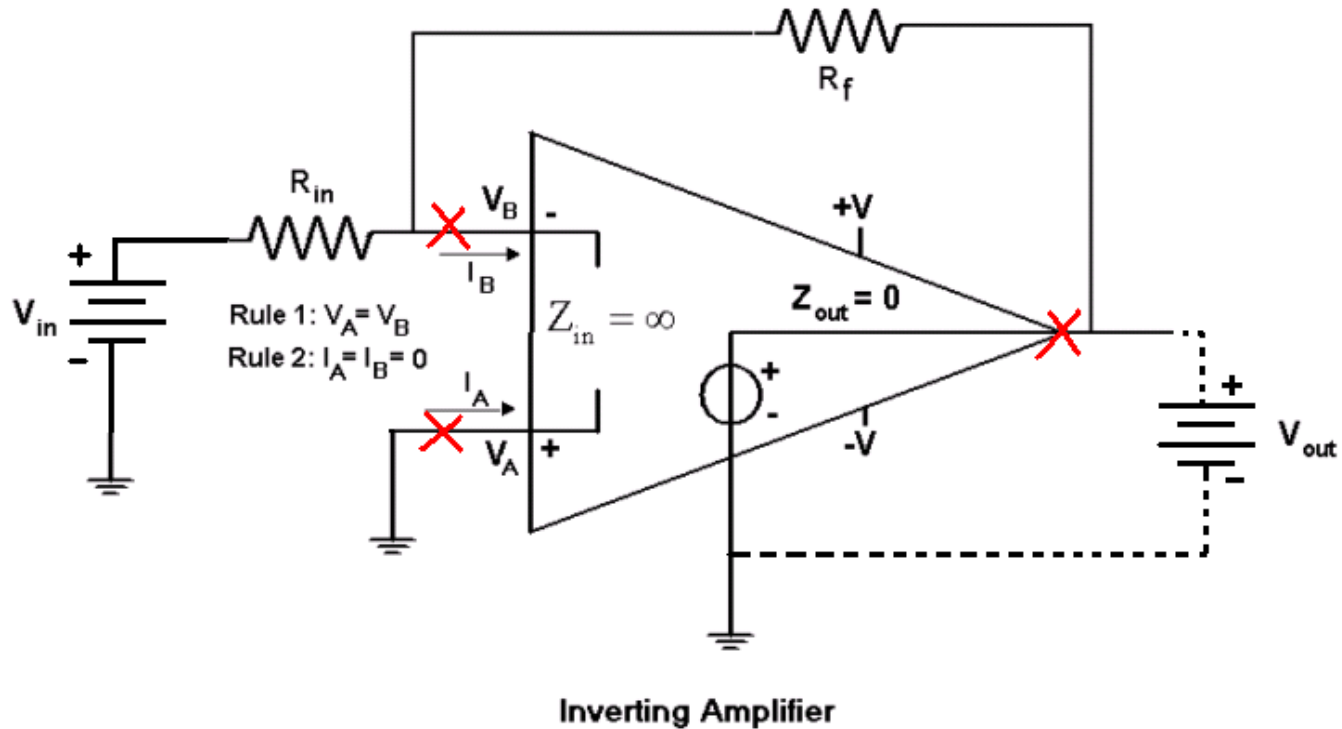
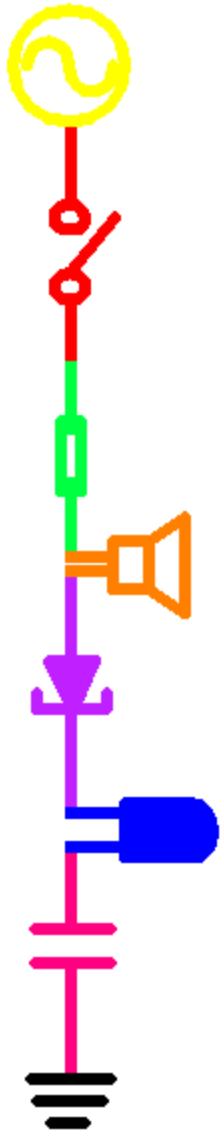

How to handle two voltage sources

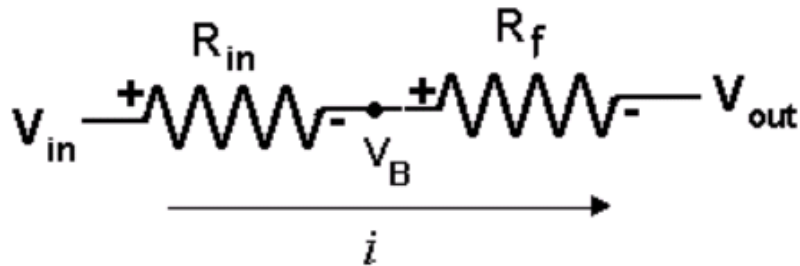

$$V_{R_{in}} = V_{in} - V_B$$

$$V_{R_f} = V_B - V_{out}$$

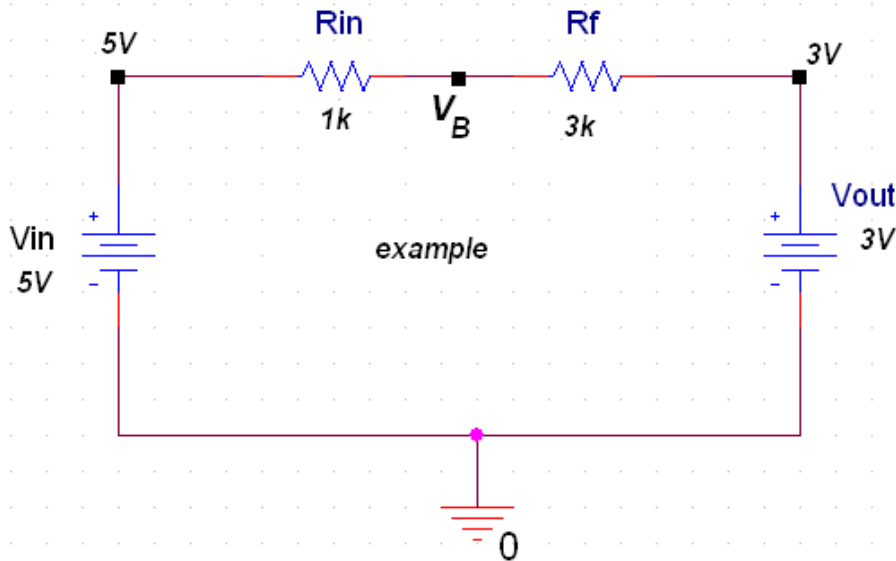

$$V_{R_{in}} = (V_{in} - V_{out}) \left(\frac{R_{in}}{R_f + R_{in}} \right)$$

$$V_{R_f} = (V_{in} - V_{out}) \left(\frac{R_f}{R_f + R_{in}} \right)$$

$$V_{R_f} = (5V - 3V) \left(\frac{3k}{3k + 1k} \right) = 1.5V \quad V_B = V_{out} + V_{R_f} = 4.5V$$



Inverting Amplifier Analysis

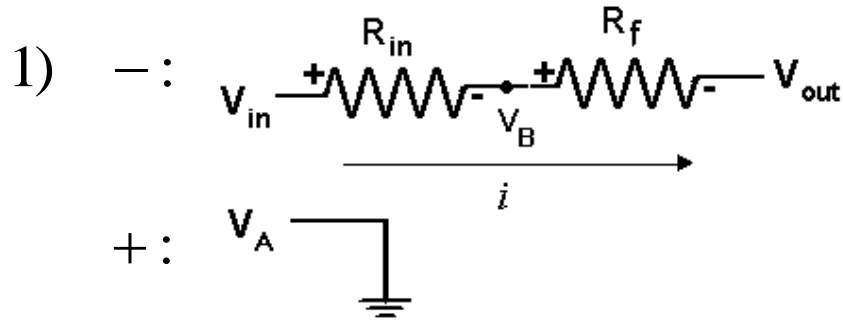
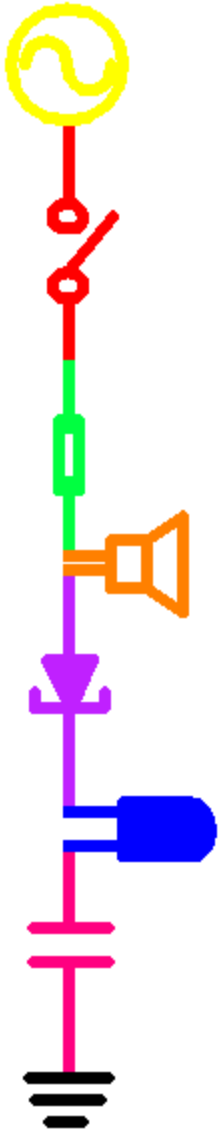

2) - :
$$i = \frac{V}{R} = \frac{V_{in} - V_B}{R_{in}} = \frac{V_B - V_{out}}{R_f}$$

+ : $V_A = 0$

3) $V_A = V_B = 0$
$$\frac{V_{in}}{R_{in}} = \frac{-V_{out}}{R_f}$$

$$\frac{V_{out}}{V_{in}} = -\frac{R_f}{R_{in}}$$

Analysis of Non-Inverting Amplifier

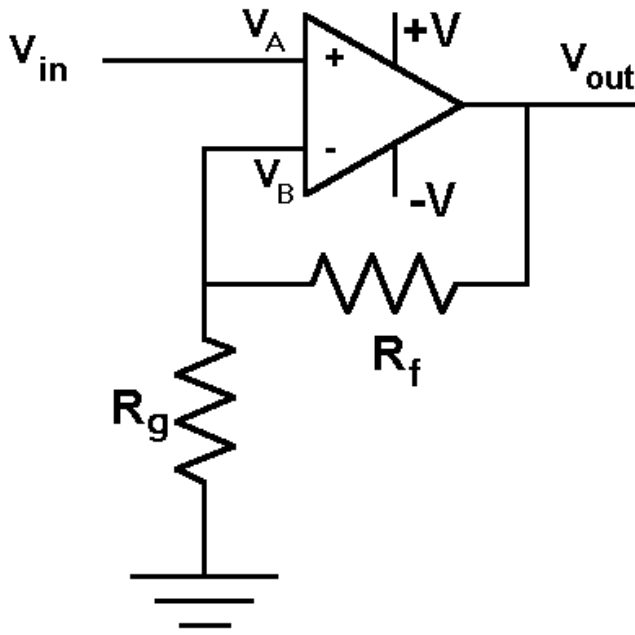
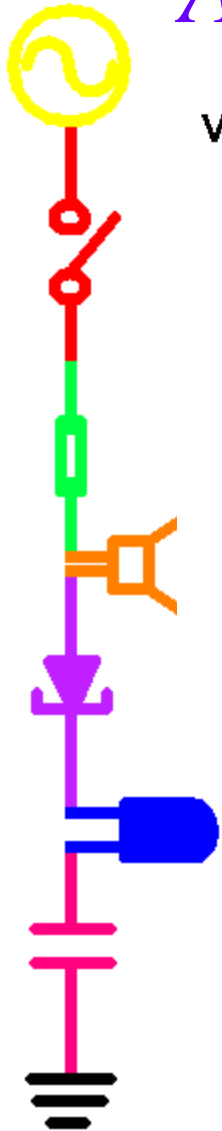

Note that step 2 uses a voltage divider to find the voltage at V_B relative to the output voltage.

2) +: $V_A = V_{in}$
 -: $V_B = \frac{R_g}{R_f + R_g} V_{out}$

3) $V_A = V_B$ $V_{in} = \frac{R_g}{R_f + R_g} V_{out}$

$$\frac{V_{out}}{V_{in}} = \frac{R_f + R_g}{R_g}$$

$$\frac{V_{out}}{V_{in}} = 1 + \frac{R_f}{R_g}$$

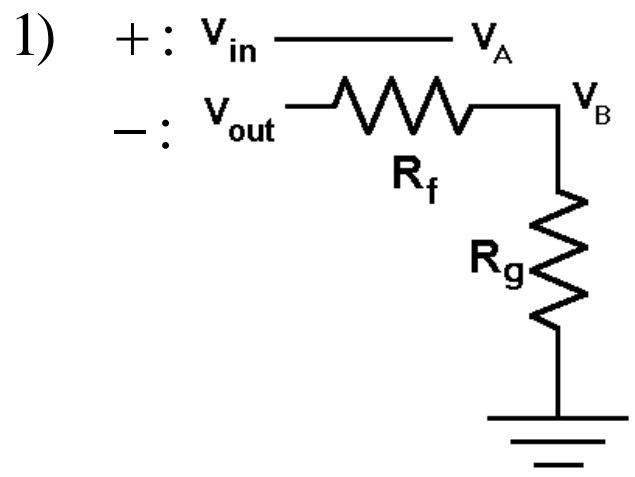

The Voltage Follower

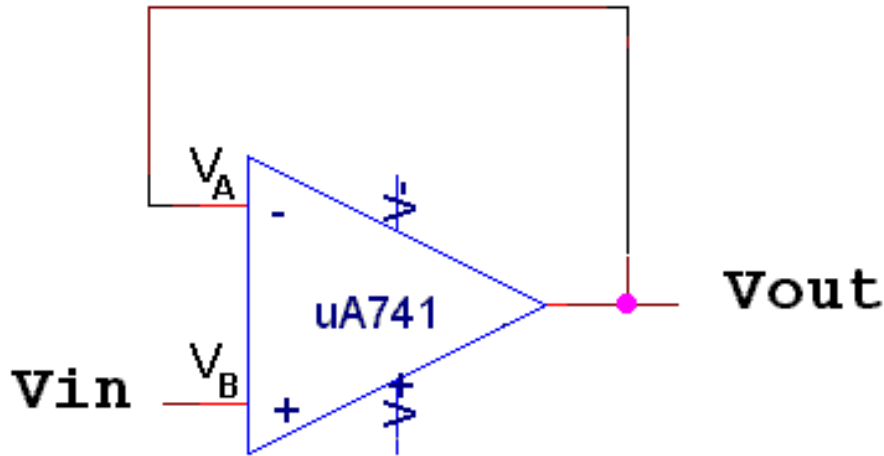
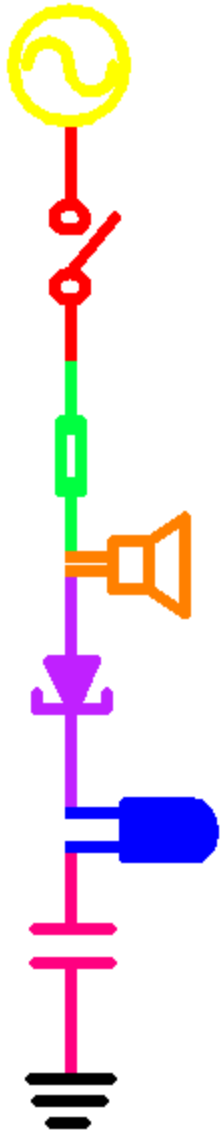

$$\frac{V_{out}}{V_{in}} = 1$$

analysis :

$$1] \quad V_A = V_{out}$$

$$2] \quad V_B = V_{in}$$

$$V_A = V_B \quad \textit{therefore,} \quad V_{out} = V_{in}$$

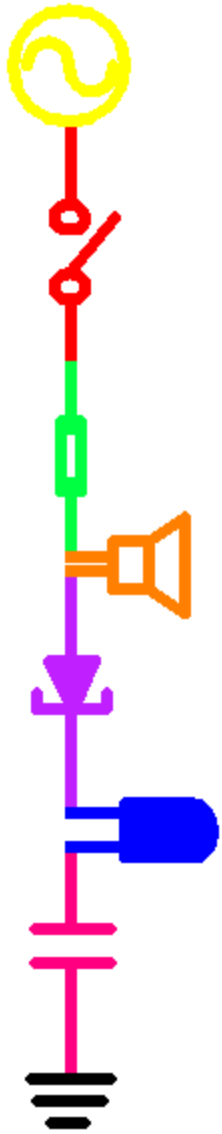

Why is it useful?

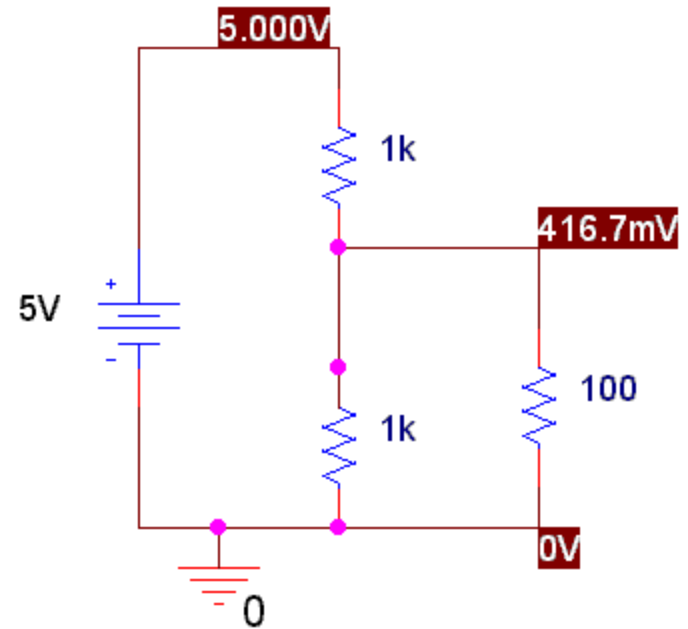
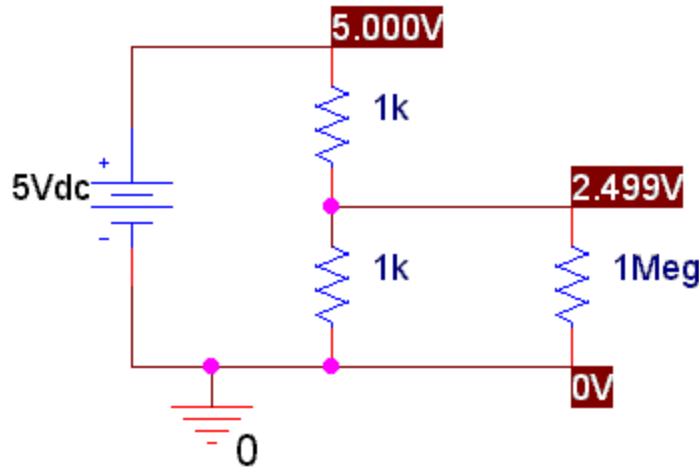

- ◆ In this voltage divider, we get a different output depending upon the load we put on the circuit.
- ◆ Why?

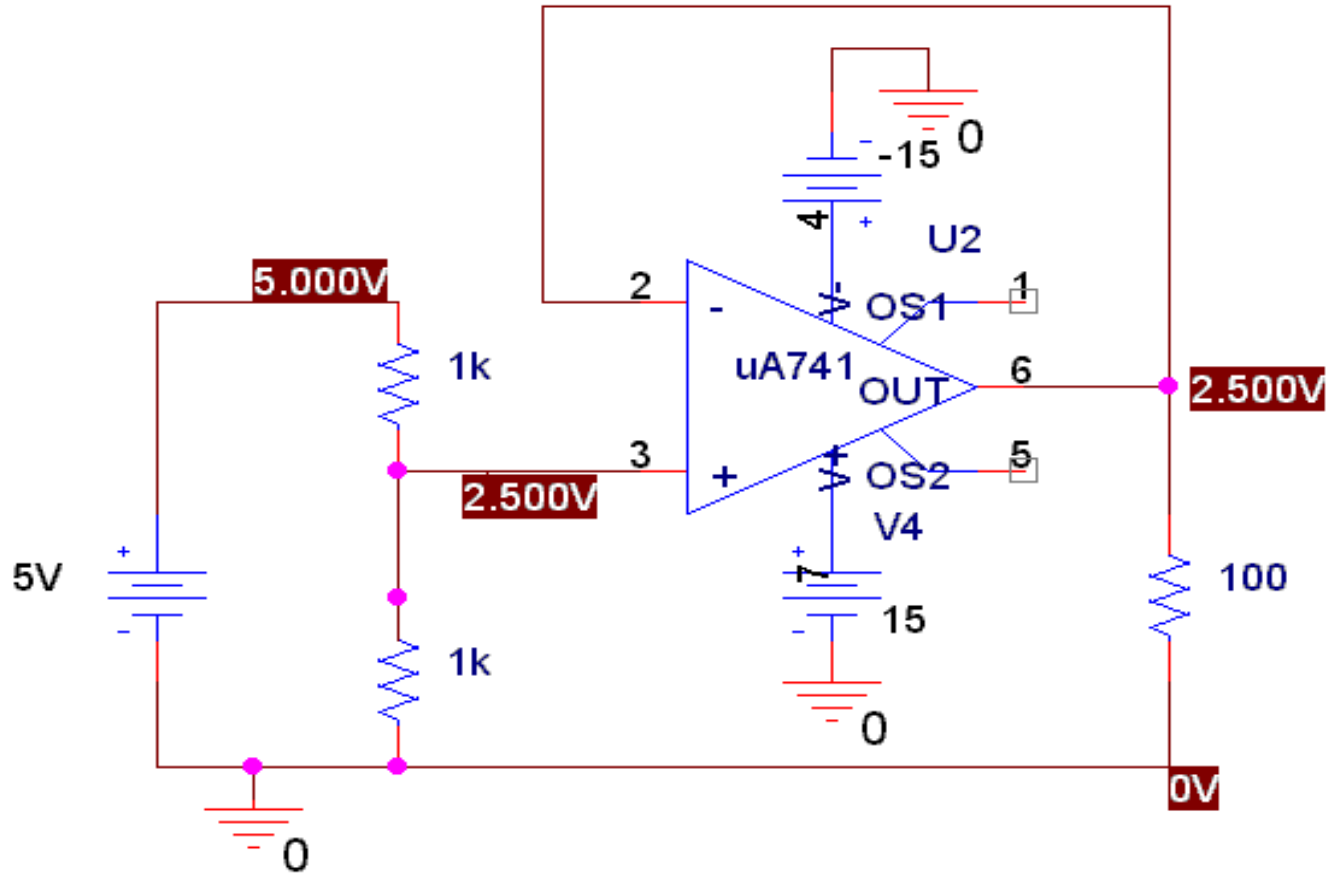
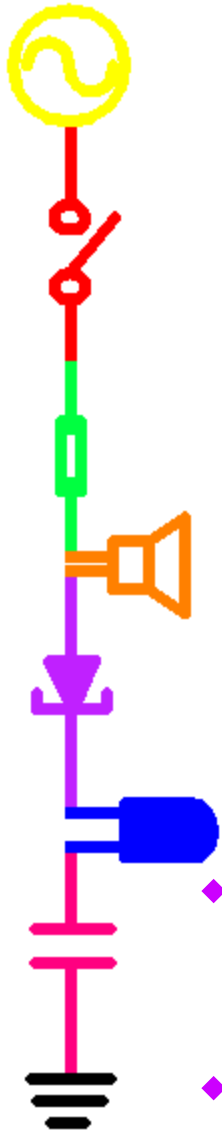

- ◆ We can use a voltage follower to convert this real voltage source into an ideal voltage source.
- ◆ The power now comes from the +/- 15 volts to the op amp and the load will not affect the output.

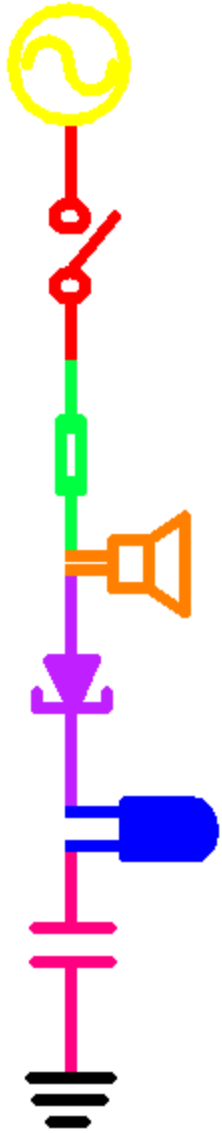

Part C

Integrators and Differentiators

- ◆ General Op-Amp Analysis
- ◆ Differentiators
- ◆ Integrators
- ◆ Comparison

Golden Rules of Op-Amp Analysis

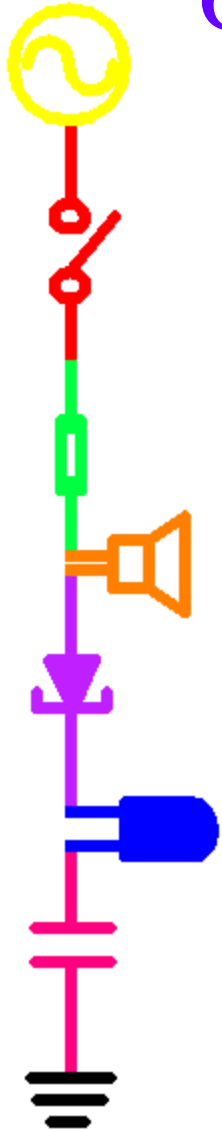

◆ Rule 1: $V_A = V_B$

- The output attempts to do whatever is necessary to make the voltage difference between the inputs zero.
- The op-amp “looks” at its input terminals and swings its output terminal around so that the external feedback network brings the input differential to zero.

◆ Rule 2: $I_A = I_B = 0$

- The inputs draw no current
- The inputs are connected to what is essentially an open circuit

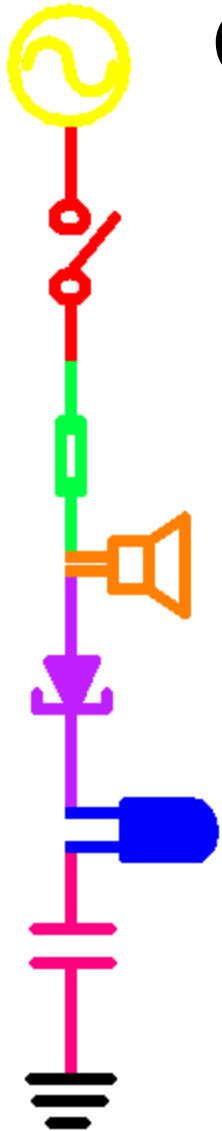

General Analysis Example(1)

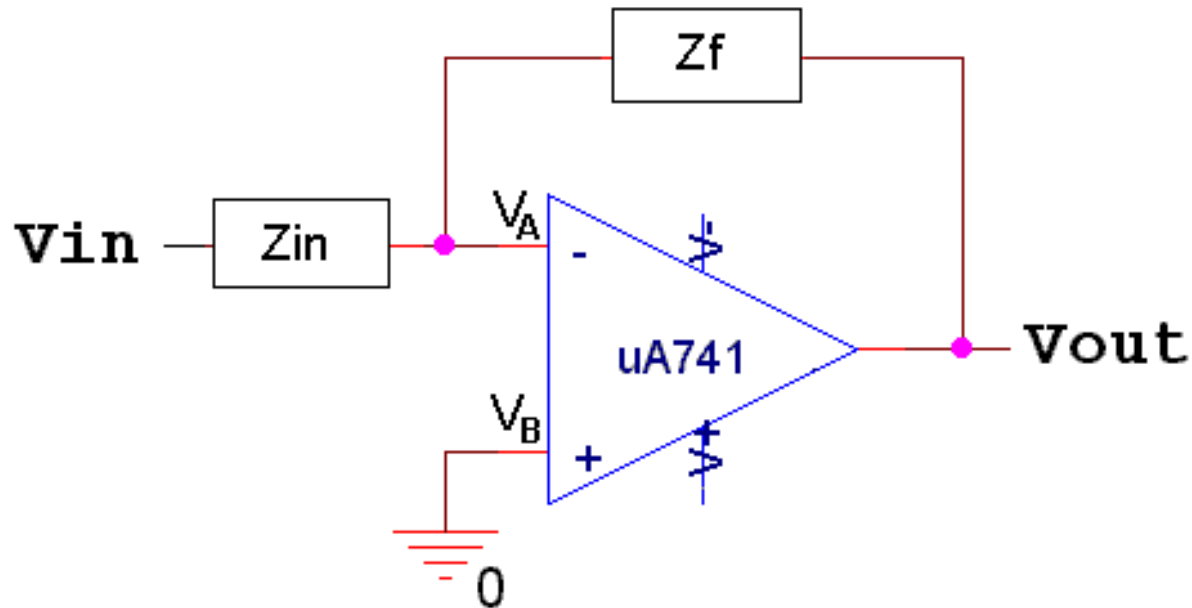

- ◆ Assume we have the circuit above, where Z_f and Z_{in} represent any combination of resistors, capacitors and inductors.



General Analysis Example(2)

- ◆ We remove the op amp from the circuit and write an equation for each input voltage.

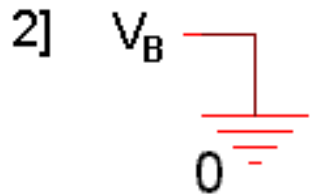
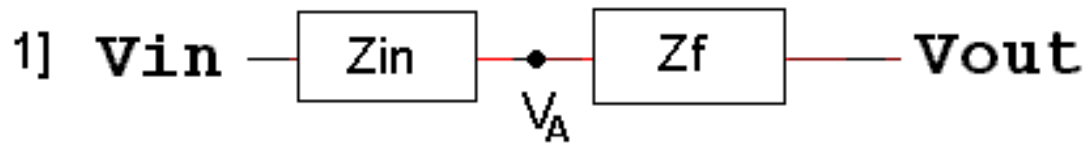

- ◆ Note that the current through Z_{in} and Z_f is the same, because equation 1] is a series circuit.



General Analysis Example(3)

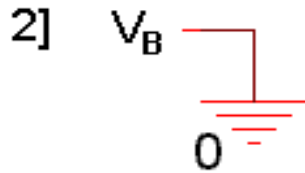
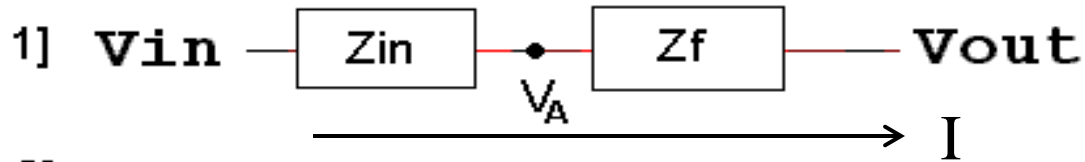

- ◆ Since $I=V/Z$, we can write the following:

$$I = \frac{V_{in} - V_A}{Z_{in}} = \frac{V_A - V_{out}}{Z_f}$$

- ◆ But $V_A = V_B = 0$, therefore:

$$\frac{V_{in}}{Z_{in}} = \frac{-V_{out}}{Z_f}$$

$$\frac{V_{out}}{V_{in}} = -\frac{Z_f}{Z_{in}}$$

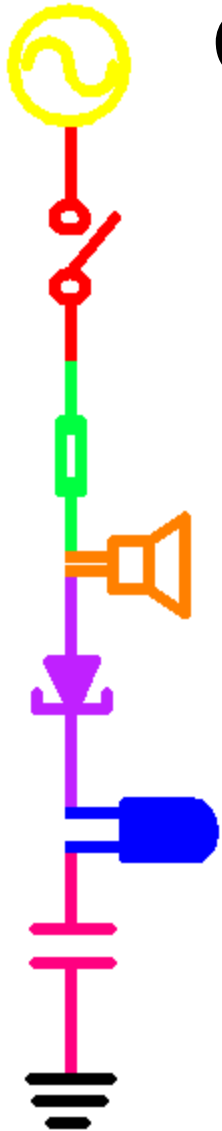

General Analysis Conclusion

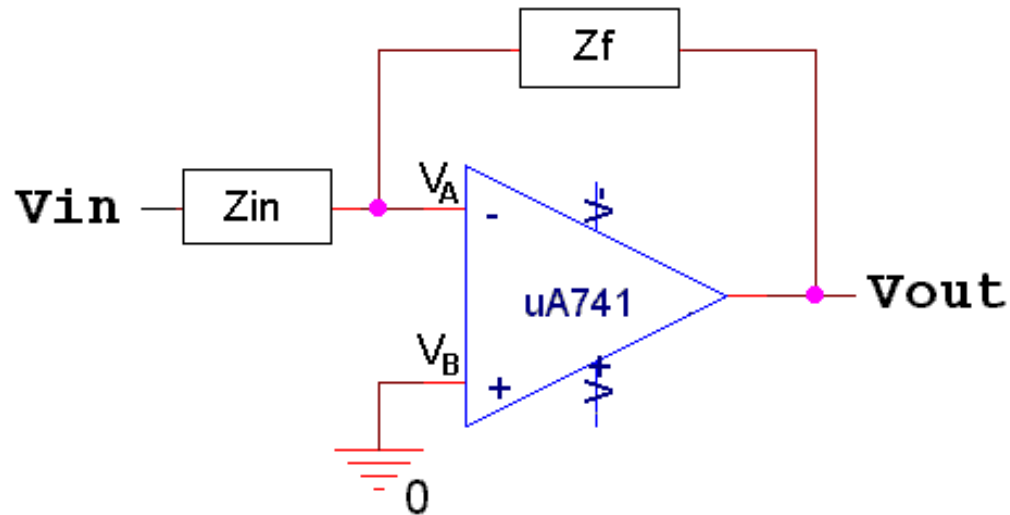

- ◆ For any op amp circuit where the positive input is grounded, as pictured above, the equation for the behavior is given by:

$$\frac{V_{out}}{V_{in}} = -\frac{Z_f}{Z_{in}}$$

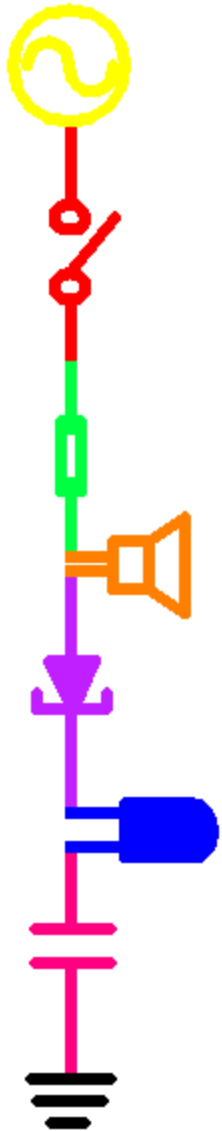

Ideal Differentiator

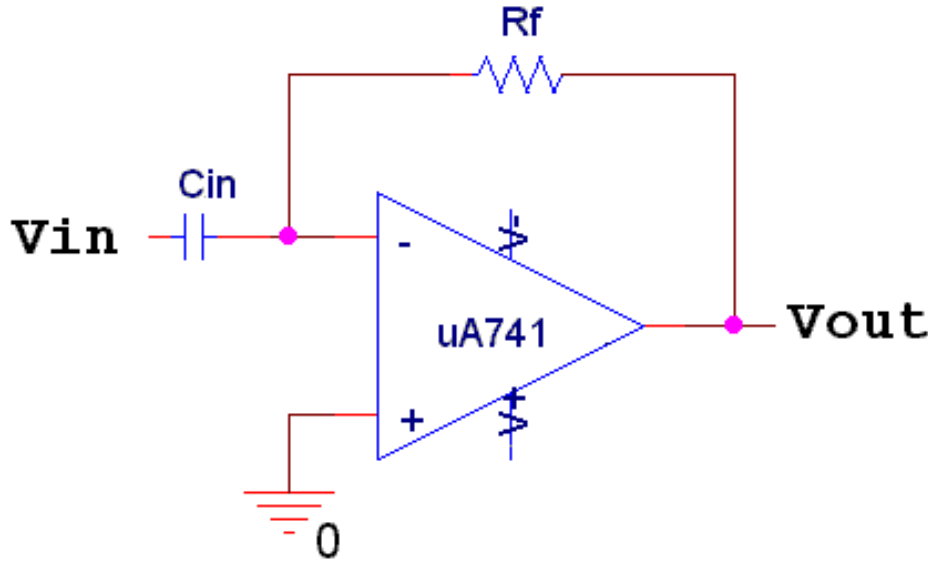

Phase shift

$j \rightarrow \pi/2$

$- \rightarrow \pm\pi$

Net $\rightarrow -\pi/2$

Amplitude
changes by a factor of
 $\omega R_f C_{in}$

analysis :

$$\frac{V_{out}}{V_{in}} = -\frac{Z_f}{Z_{in}} = -\frac{R_f}{1/j\omega C_{in}} = -j\omega R_f C_{in}$$



Analysis in time domain

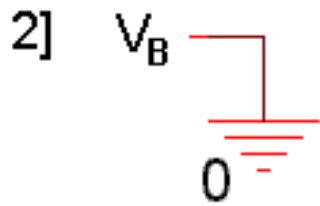
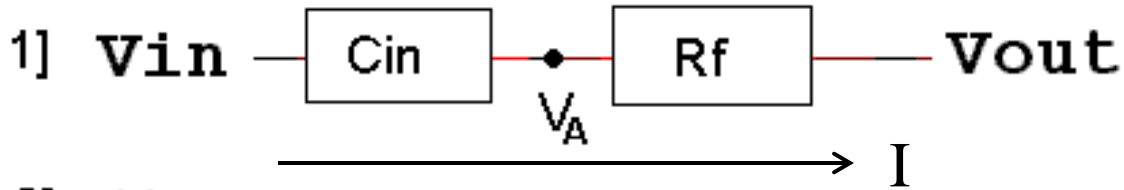

$$I_{C_{in}} = C_{in} \frac{dV_{C_{in}}}{dt} \quad V_{R_f} = I_{R_f} R_f \quad I_{C_{in}} = I_{R_f} = I$$

$$I = C_{in} \frac{d(V_{in} - V_A)}{dt} = \frac{V_A - V_{out}}{R_f} \quad V_A = V_B = 0$$

therefore, $V_{out} = -R_f C_{in} \frac{dV_{in}}{dt}$

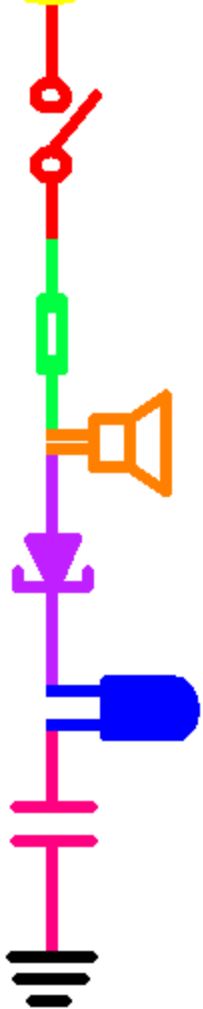

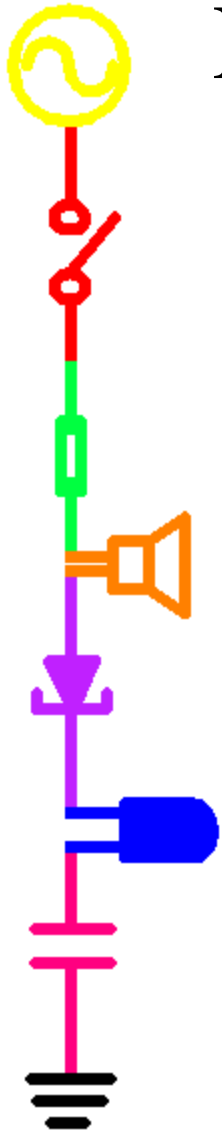

Problem with ideal differentiator

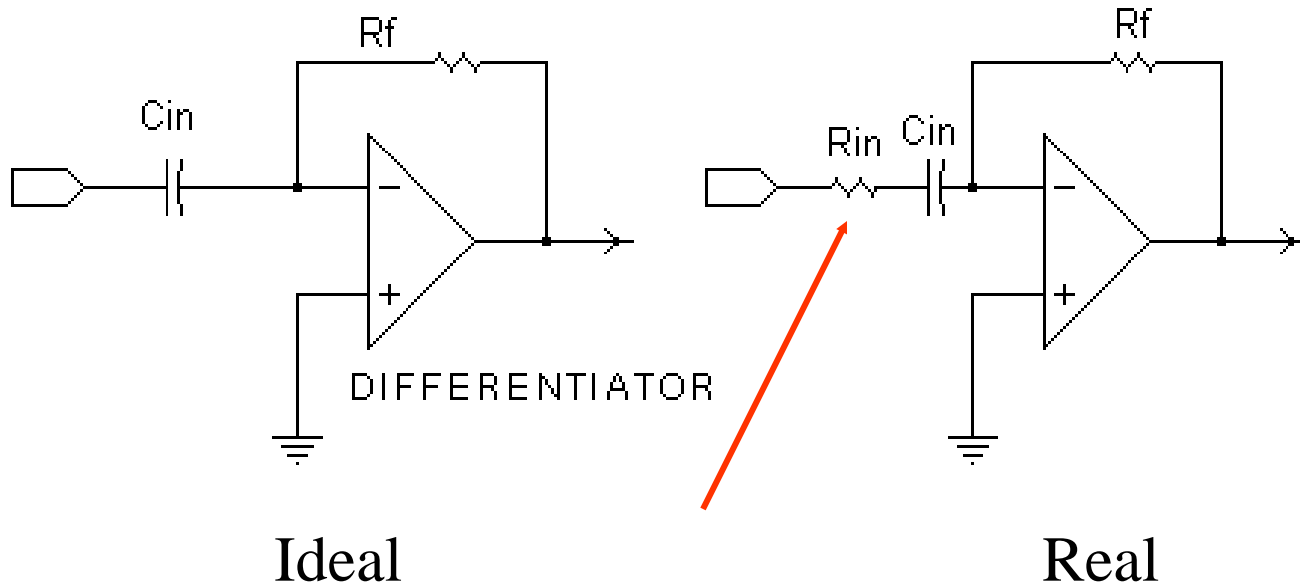

Circuits will always have some kind of input resistance, even if it is just the 50 ohms or less from the function generator.



Analysis of real differentiator

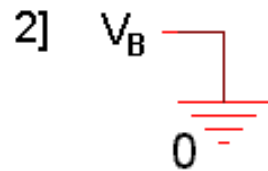
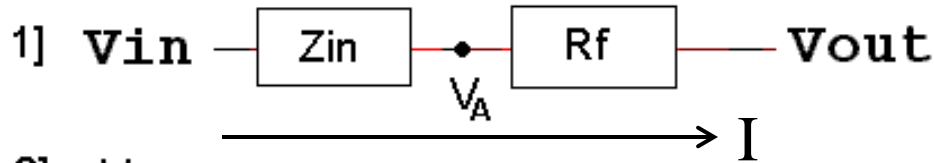

$$Z_{in} = R_{in} + \frac{1}{j\omega C_{in}}$$

$$\frac{V_{out}}{V_{in}} = -\frac{Z_f}{Z_{in}} = -\frac{R_f}{R_{in} + \frac{1}{j\omega C_{in}}} = -\frac{j\omega R_f C_{in}}{j\omega R_{in} C_{in} + 1}$$

Low Frequencies

$$\frac{V_{out}}{V_{in}} = -j\omega R_f C_{in}$$

ideal differentiator

High Frequencies

$$\frac{V_{out}}{V_{in}} = -\frac{R_f}{R_{in}}$$

inverting amplifier



Comparison of ideal and non-ideal

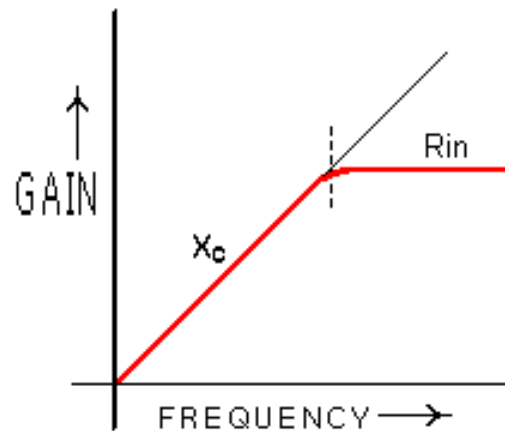
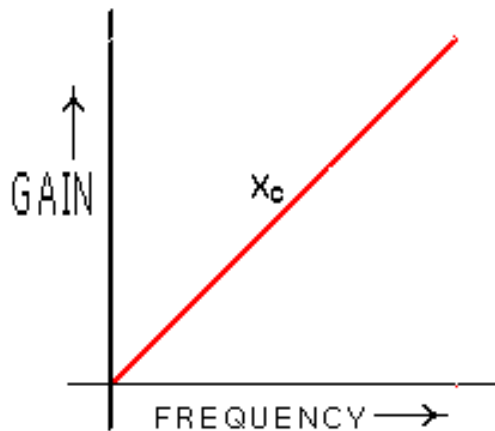
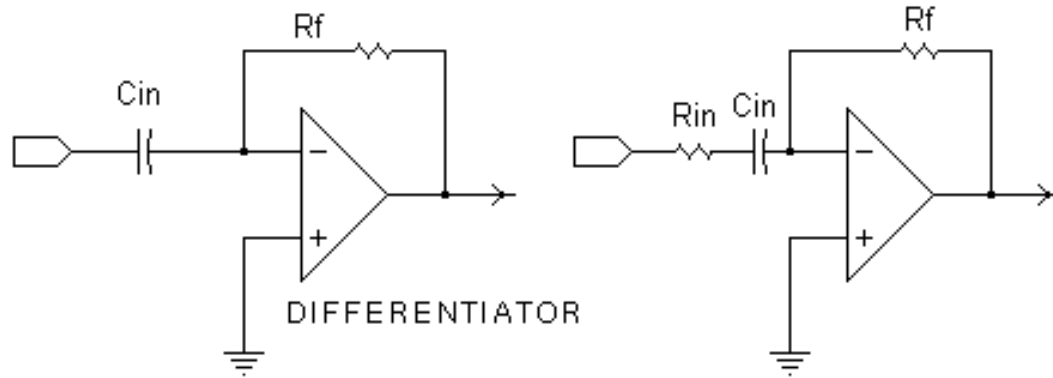

Both differentiate in sloped region.

Both curves are idealized, real output is less well behaved.

A real differentiator works at frequencies below $\omega_c = 1/R_{in}C_{in}$

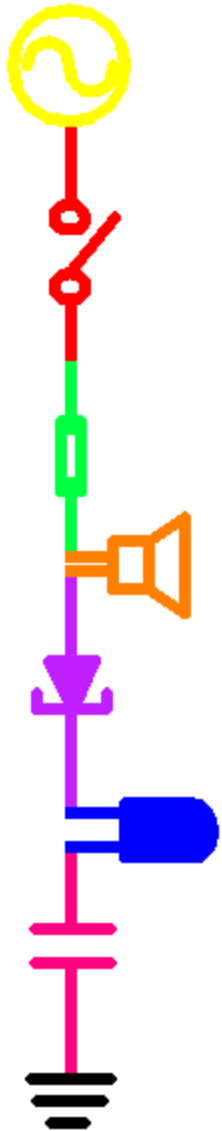

Ideal Integrator

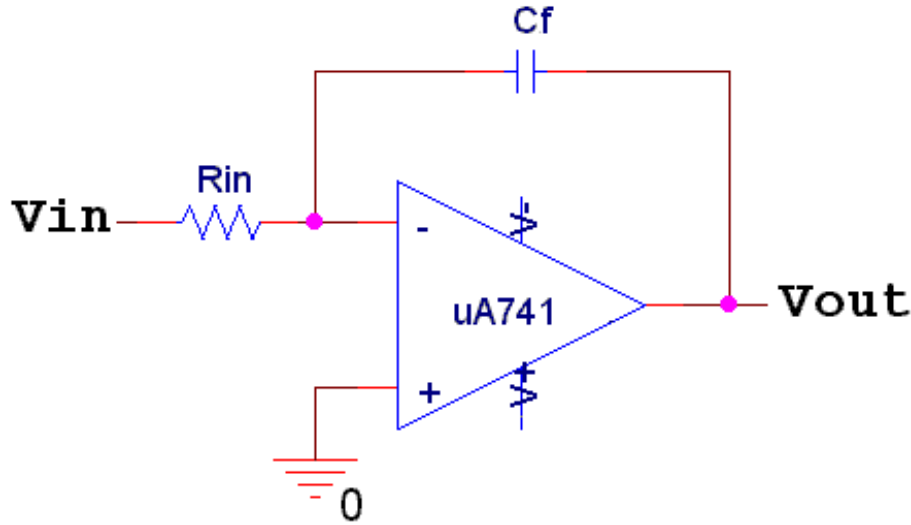

Phase shift

$$1/j \rightarrow -\pi/2$$

$$- \rightarrow \pm\pi$$

$$\text{Net} \rightarrow \pi/2$$

Amplitude
changes by a
factor of
 $1/\omega R_{in} C_f$

analysis :

$$\frac{V_{out}}{V_{in}} = -\frac{Z_f}{Z_{in}} = -\frac{1/j\omega C_f}{R_{in}} = -\frac{1}{j\omega R_{in} C_f}$$



Analysis in time domain

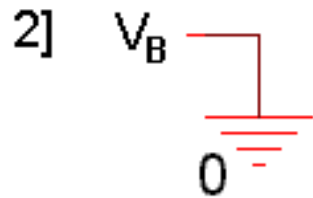
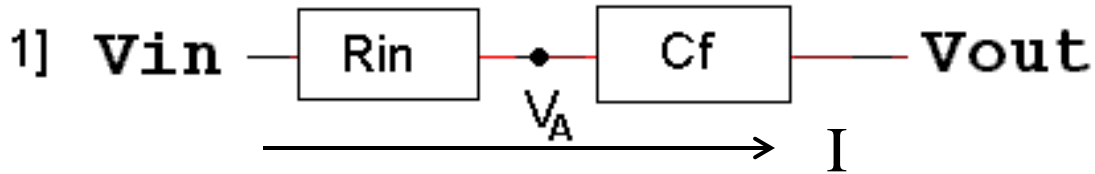

$$V_{Rin} = I_{Rin} R_{in} \quad I_{Cf} = C_f \frac{dV_{Cf}}{dt} \quad I_{Cf} = I_{Rin} = I$$

$$I = \frac{V_{in} - V_A}{R_{in}} = C_f \frac{d(V_A - V_{out})}{dt} \quad V_A = V_B = 0$$

$$\frac{dV_{out}}{dt} = -\frac{1}{R_{in} C_f} V_{in}$$

$$V_{out} = -\frac{1}{R_{in} C_f} \int V_{in} dt (+ V_{DC})$$



Problem with ideal integrator (1)

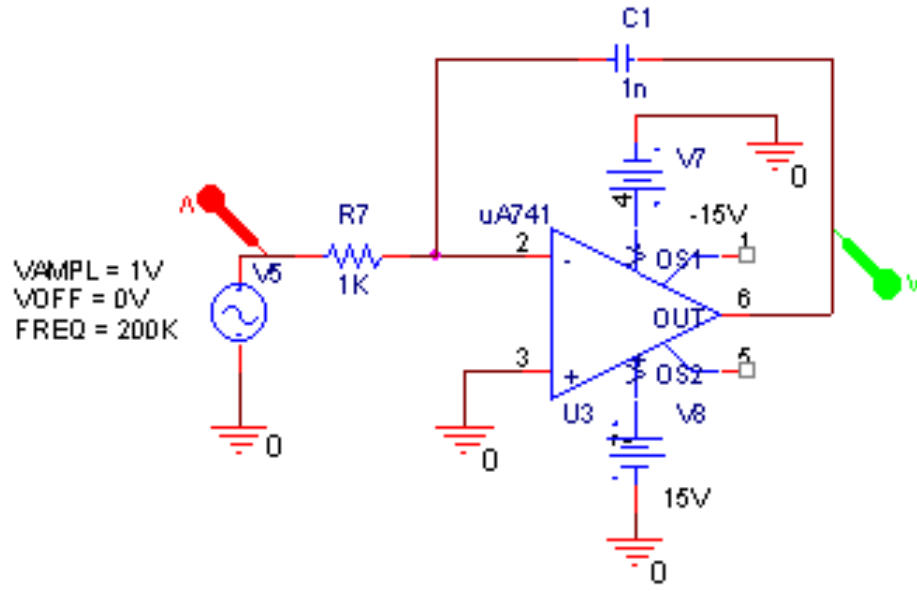

VAMPL = 1V
Vdff = 0V
FREQ = 200K

No DC offset.
Works OK.

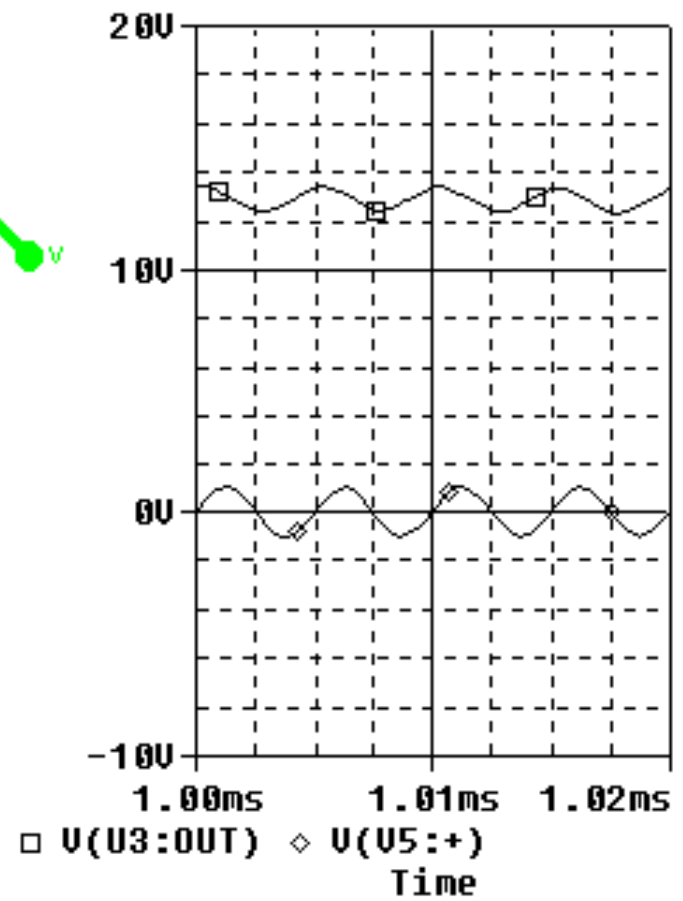



Problem with ideal integrator (2)

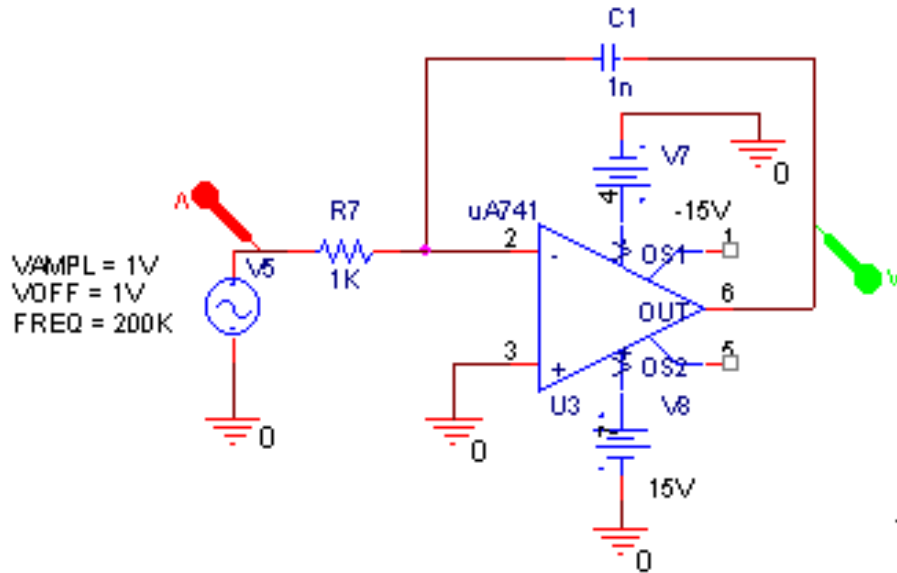

VAMPL = 1V
VOFF = 1V
FREQ = 200K

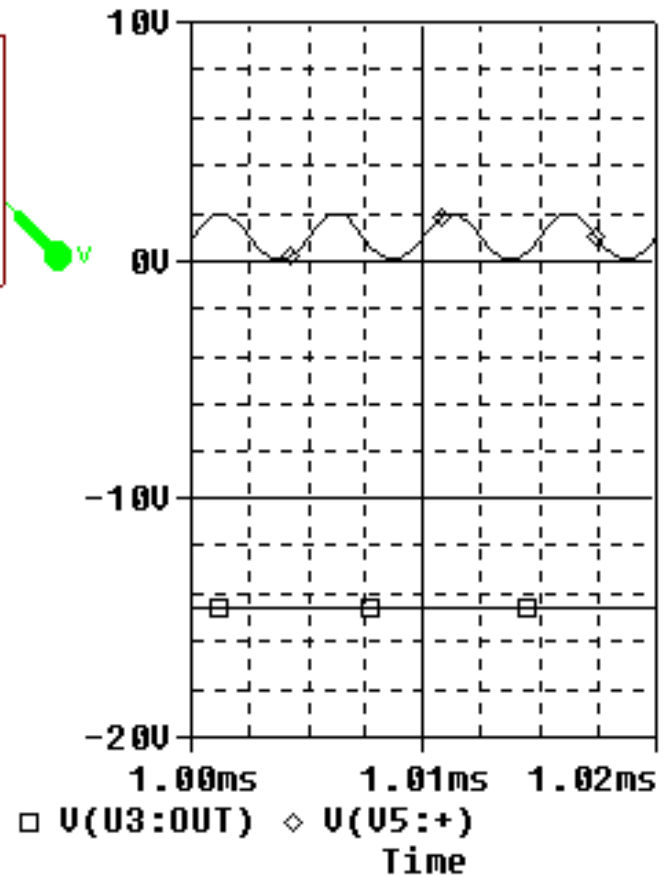

With DC offset.

Saturates immediately.

What is the integration of a constant?

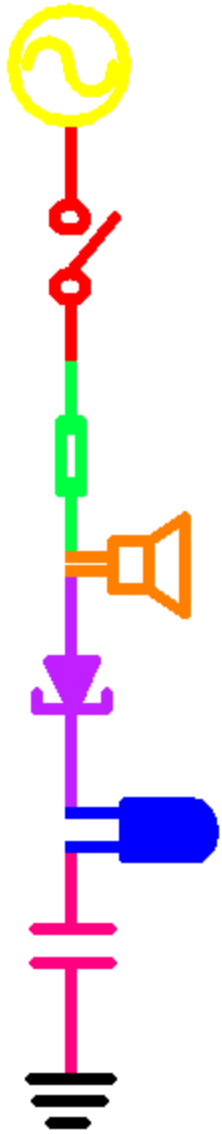

Miller (non-ideal) Integrator

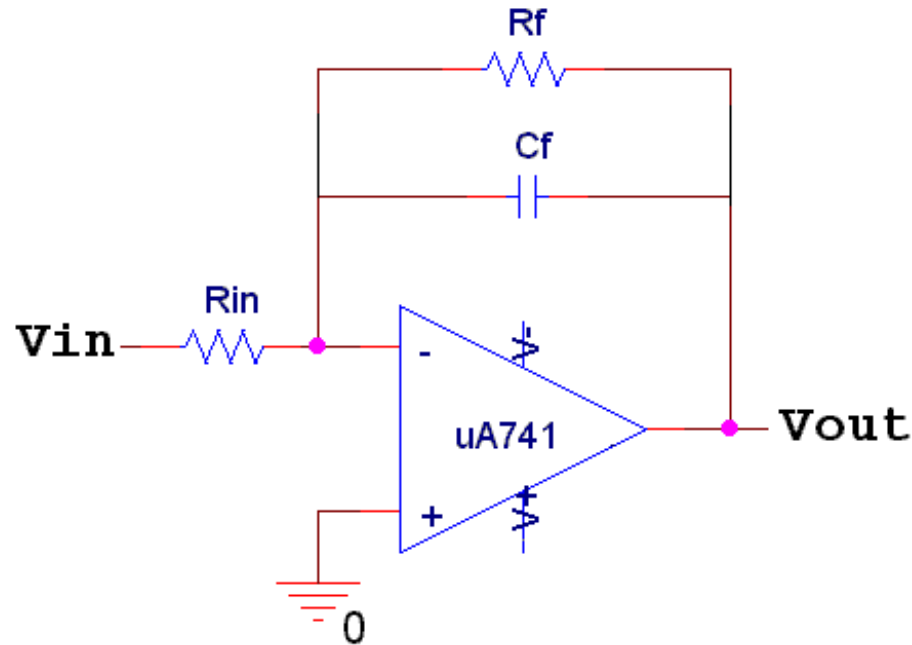

- ◆ If we add a resistor to the feedback path, we get a device that behaves better, but does not integrate at all frequencies.

Behavior of Miller integrator

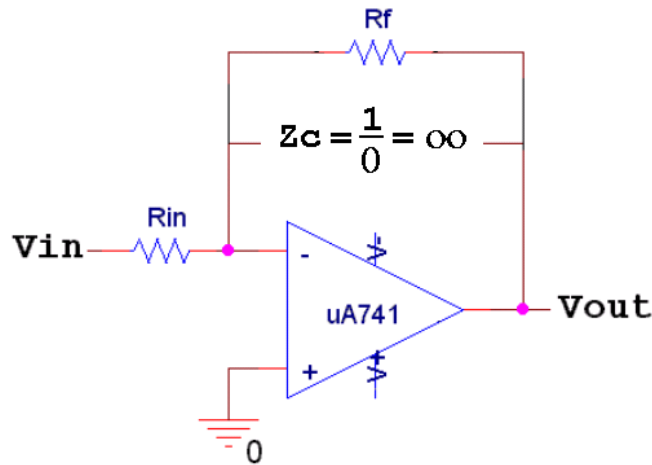

Low Frequencies

$$\frac{V_{out}}{V_{in}} = -\frac{Z_f}{Z_{in}} = -\frac{R_f}{R_{in}}$$

inverting amplifier

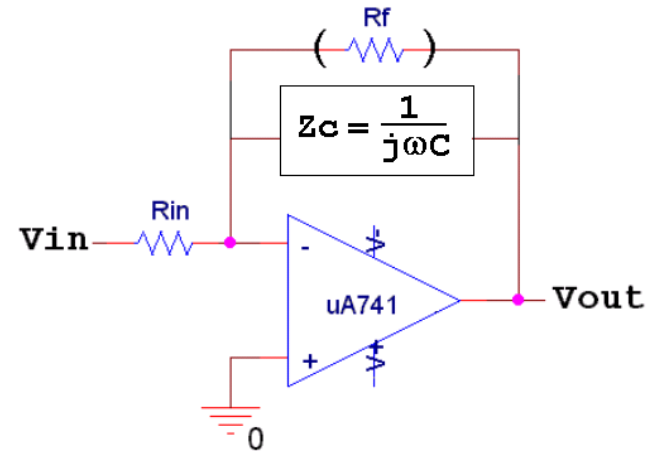

High Frequencies

$$\frac{V_{out}}{V_{in}} = -\frac{Z_f}{Z_{in}} = \frac{-1}{j\omega R_{in} C_f}$$

ideal integrator

The influence of the capacitor dominates at higher frequencies. Therefore, it acts as an integrator at higher frequencies, where it also tends to attenuate (make less) the signal.

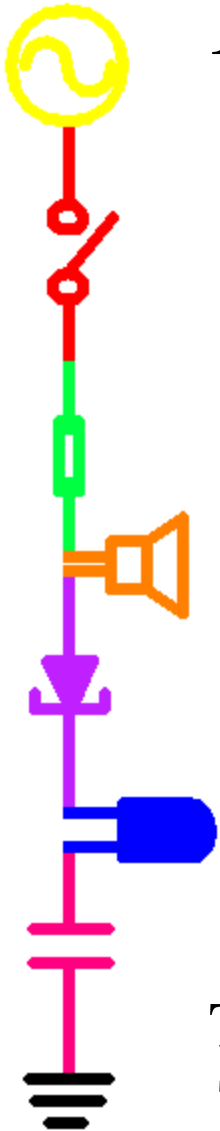

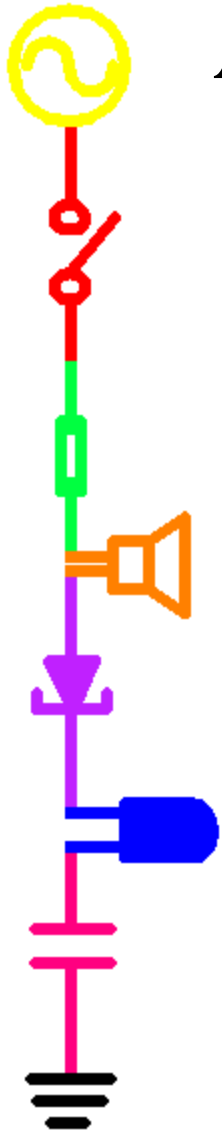

Analysis of Miller integrator

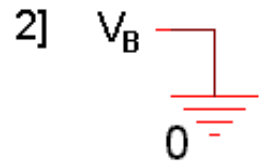
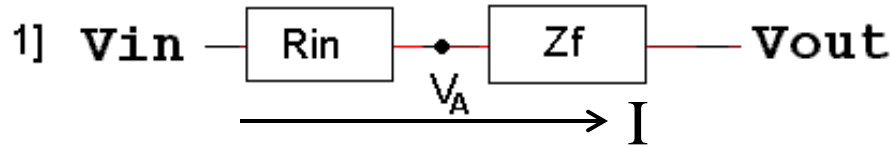

$$Z_f = \frac{R_f \cdot \frac{1}{j\omega C_f}}{R_f + \frac{1}{j\omega C_f}} = \frac{R_f}{j\omega R_f C_f + 1}$$

$$\frac{V_{out}}{V_{in}} = - \frac{Z_f}{Z_{in}} = - \frac{\frac{R_f}{j\omega R_f C_f + 1}}{R_{in}} = - \frac{R_f}{j\omega R_{in} R_f C_f + R_{in}}$$

Low Frequencies

$$\frac{V_{out}}{V_{in}} = - \frac{R_f}{R_{in}}$$

inverting amplifier

High Frequencies

$$\frac{V_{out}}{V_{in}} = - \frac{1}{j\omega R_{in} C_f}$$

ideal integrator



Comparison of ideal and non-ideal

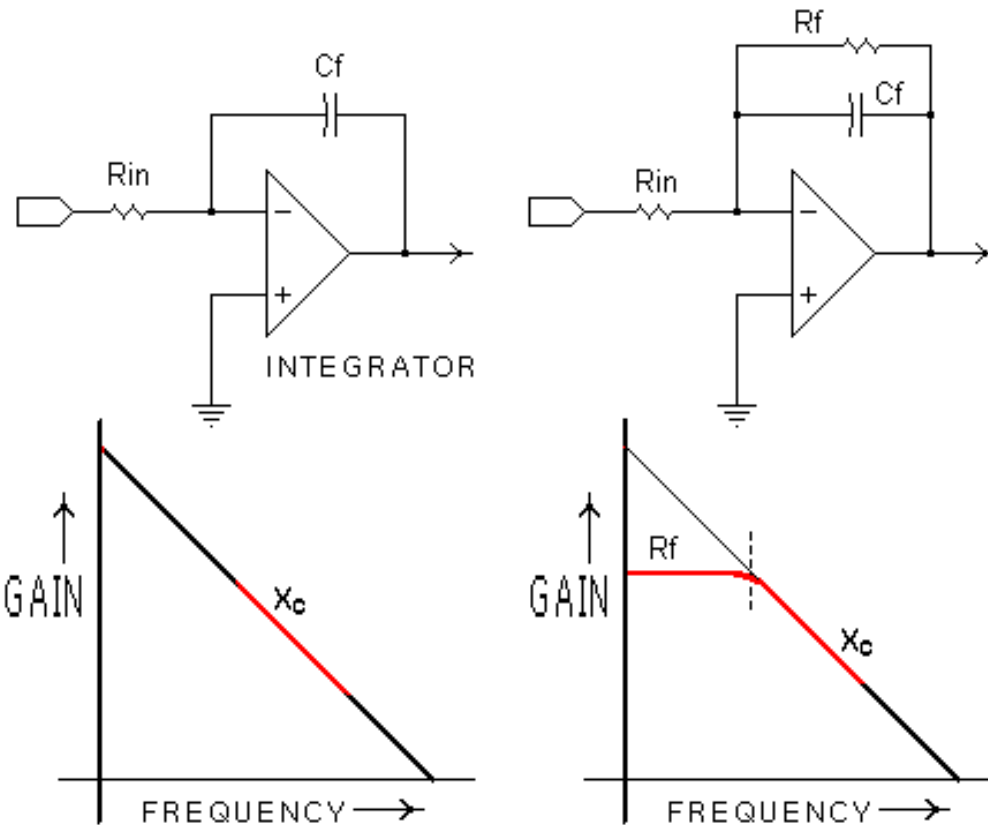

Both integrate in sloped region.

Both curves are idealized, real output is less well behaved.

A real integrator works at frequencies above $\omega_c = 1/R_f C_f$

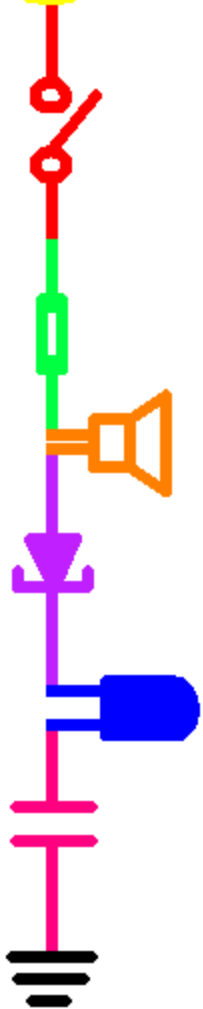

Problem solved with Miller integrator

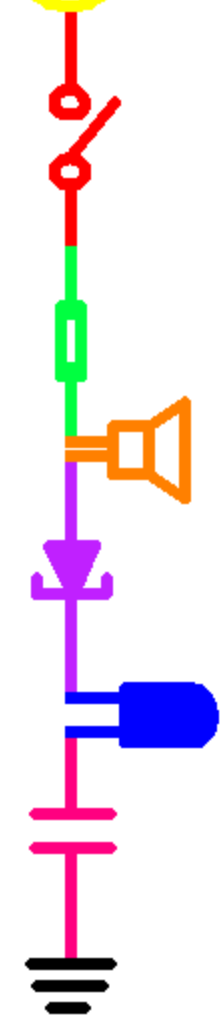

VAMPL = 1V
VOFF = 1V
FREQ = 200K

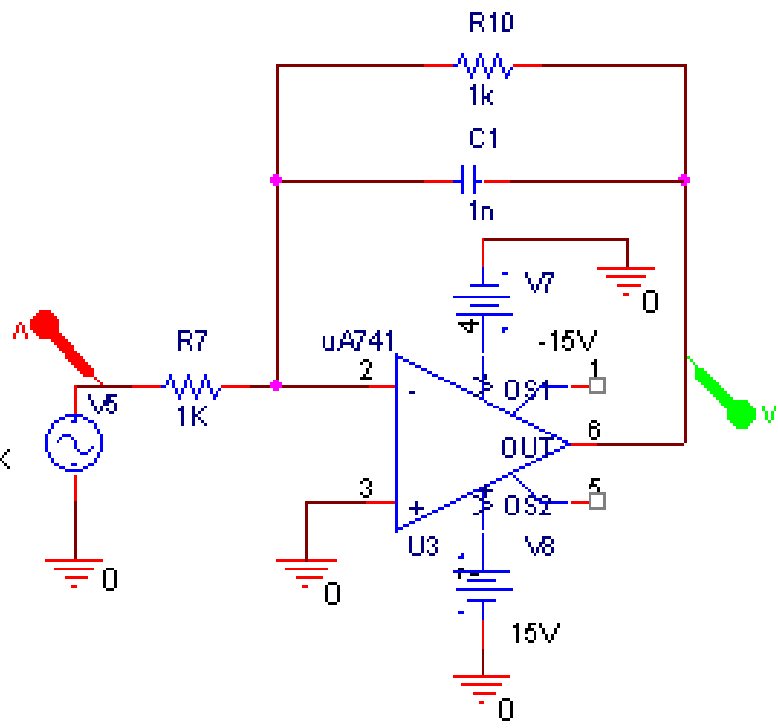

With DC offset.
Still integrates fine.

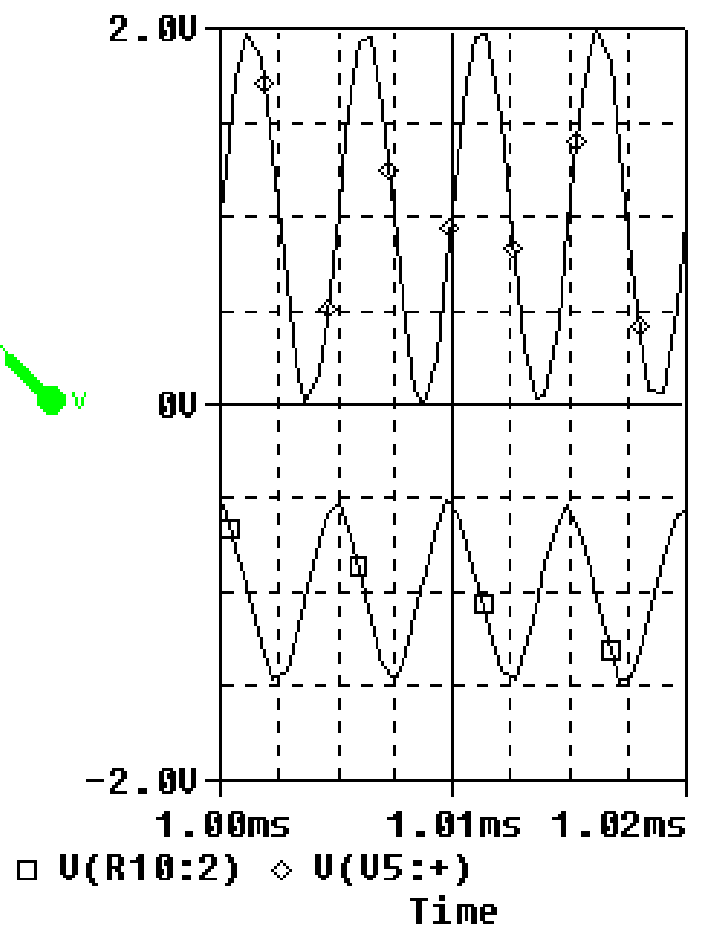



Why use a Miller integrator?

- ◆ Would the ideal integrator work on a signal with no DC offset?
- ◆ Is there such a thing as a perfect signal in real life?
 - noise will always be present
 - ideal integrator will integrate the noise
- ◆ Therefore, we use the Miller integrator for real circuits.
- ◆ Miller integrators work as integrators at $\omega > \omega_c$ where $\omega_c = 1/R_f C_f$

Comparison

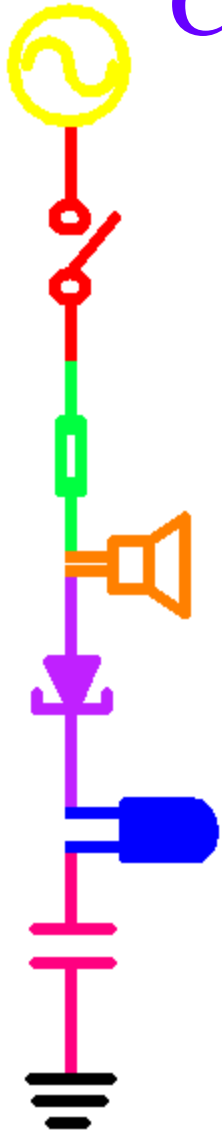

	Differentiaion	Integration
original signal	$v(t)=A\sin(\omega t)$	$v(t)=A\sin(\omega t)$
mathematically	$dv(t)/dt = A\omega\cos(\omega t)$	$\int v(t)dt = -(A/\omega)\cos(\omega t)$
mathematical phase shift	+90 (sine to cosine)	-90 (sine to -cosine)
mathematical amplitude change	ω	$1/\omega$
$H(j\omega)$	$H(j\omega) = -j\omega RC$	$H(j\omega) = -1/j\omega RC = j/\omega RC$
electronic phase shift	-90 (-j)	+90 (+j)
electronic amplitude change	ωRC	$1/\omega RC$

- ◆ The op amp circuit will *invert* the signal and multiply the mathematical amplitude by RC (differentiator) or $1/RC$ (integrator)

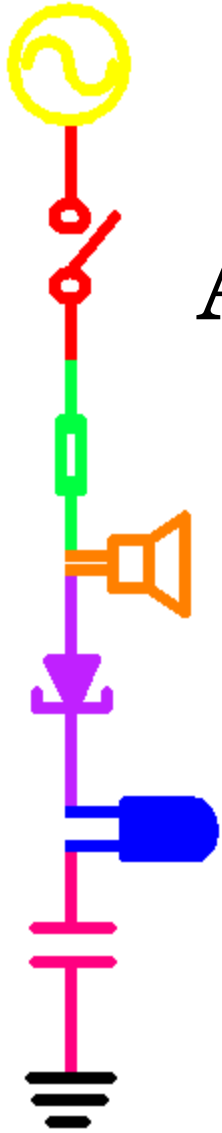

Part D

Adding and Subtracting Signals

- ◆ Op-Amp Adders
- ◆ Differential Amplifier
- ◆ Op-Amp Limitations
- ◆ Analog Computers

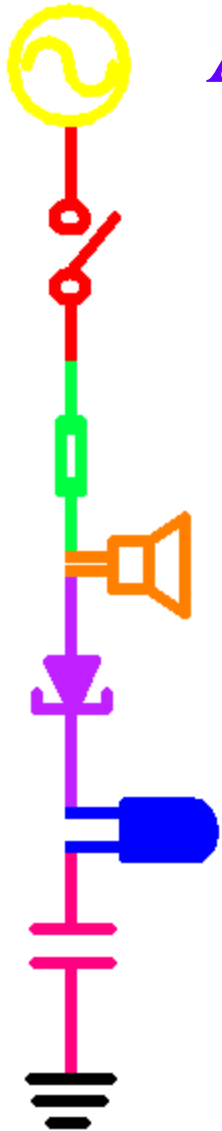

Adders

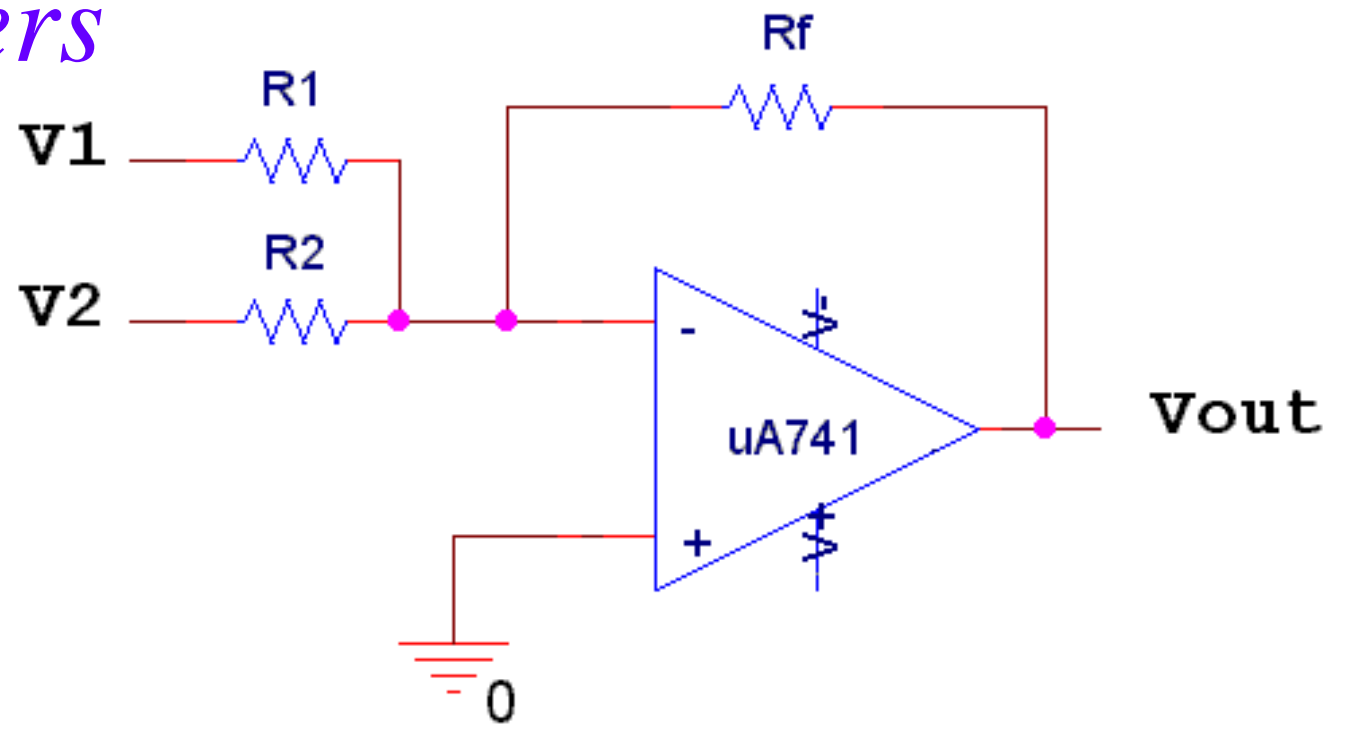

$$V_{out} = -R_f \left(\frac{V_1}{R_1} + \frac{V_2}{R_2} \right)$$

if $R_1 = R_2$ then $\frac{V_{out}}{V_1 + V_2} = -\frac{R_f}{R_1}$

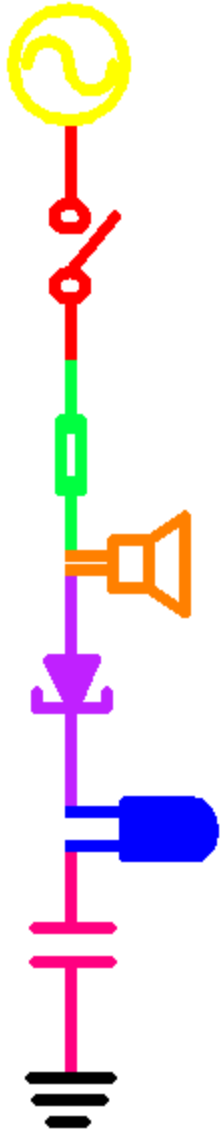

Weighted Adders

- ◆ Unlike differential amplifiers, adders are also useful when $R_1 \neq R_2$.
- ◆ This is called a “Weighted Adder”
- ◆ A weighted adder allows you to combine several different signals with a different gain on each input.
- ◆ You can use weighted adders to build audio mixers and digital-to-analog converters.



Analysis of weighted adder

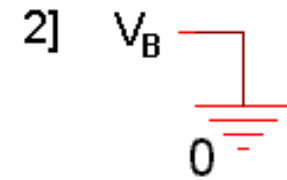
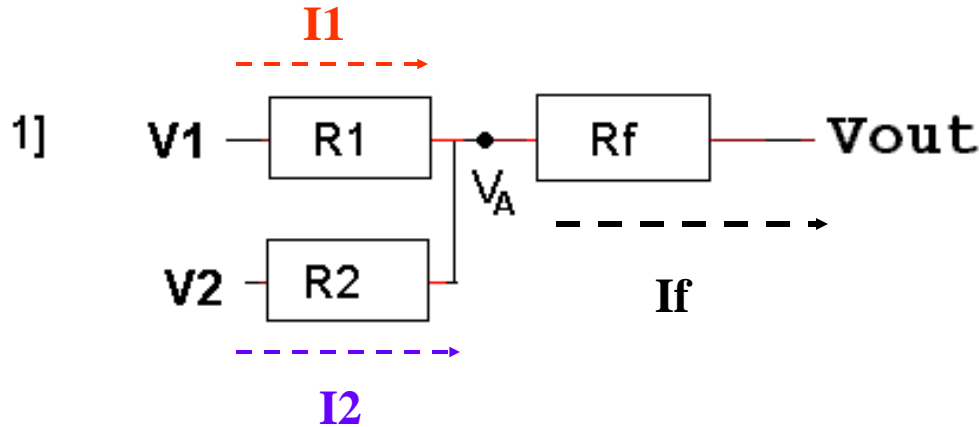

$$I_f = I_1 + I_2 \quad I_1 = \frac{V_1 - V_A}{R_1} \quad I_2 = \frac{V_2 - V_A}{R_2} \quad I_f = \frac{V_A - V_{out}}{R_f}$$

$$\frac{V_A - V_{out}}{R_f} = \frac{V_1 - V_A}{R_1} + \frac{V_2 - V_A}{R_2} \quad V_A = V_B = 0$$

$$\frac{-V_{out}}{R_f} = \frac{V_1}{R_1} + \frac{V_2}{R_2}$$

$$V_{out} = -R_f \left(\frac{V_1}{R_1} + \frac{V_2}{R_2} \right)$$

Differential (or Difference) Amplifier

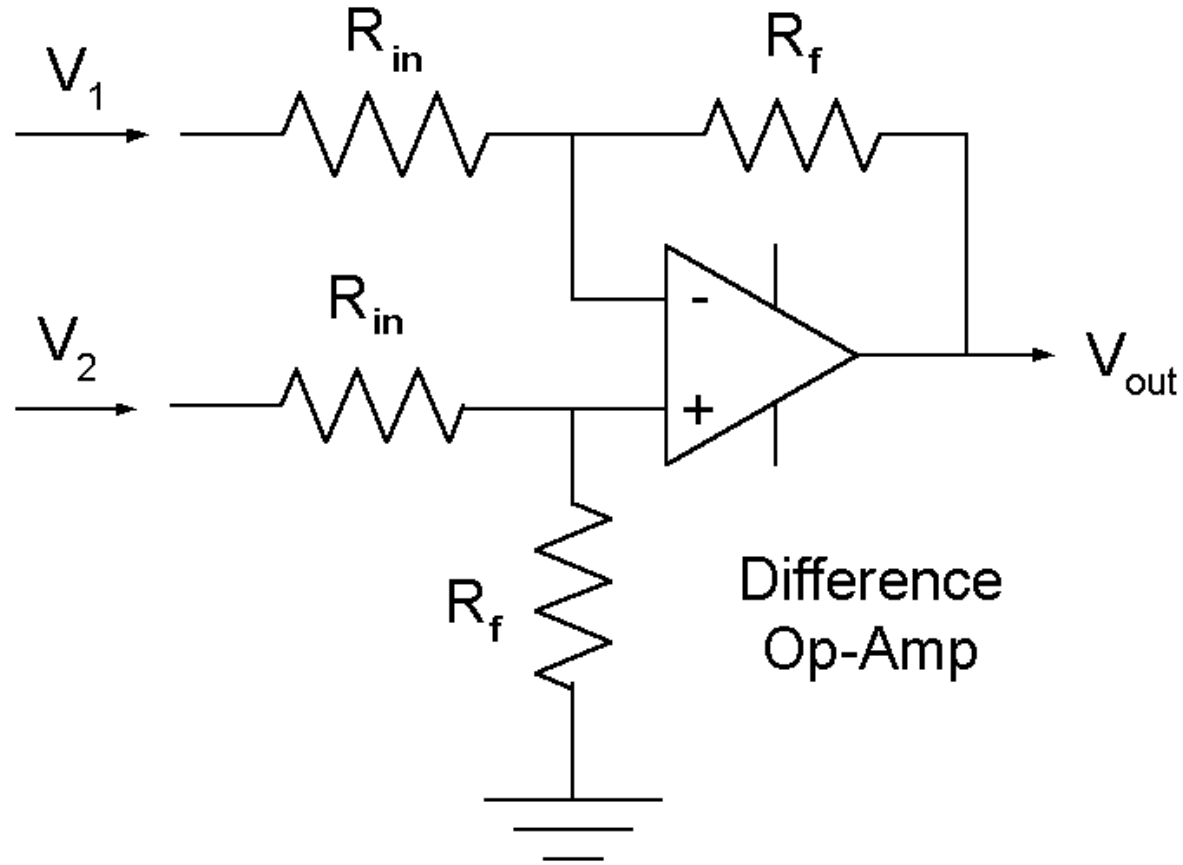

$$V_{out} = \left(\frac{R_f}{R_{in}} \right) (V_2 - V_1) \quad A = \frac{R_f}{R_{in}}$$

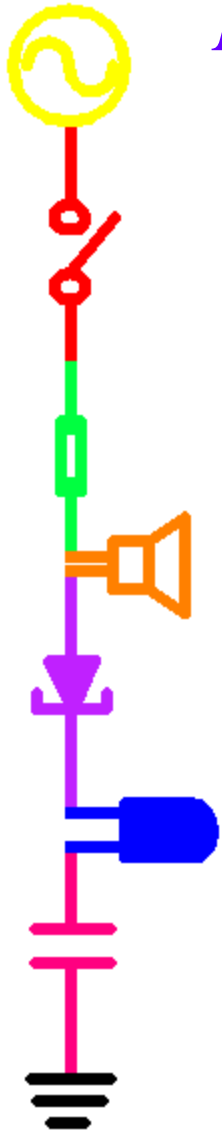

Analysis of Difference Amplifier(1)

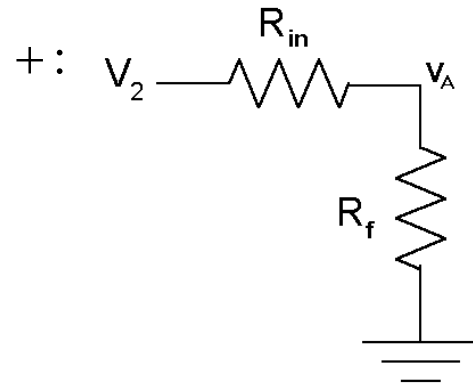
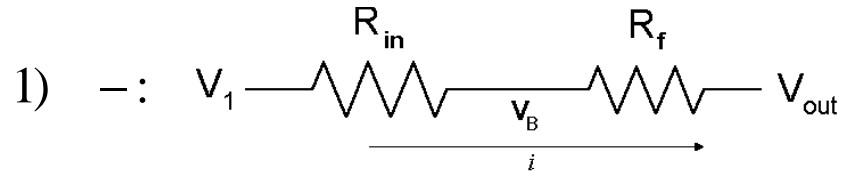
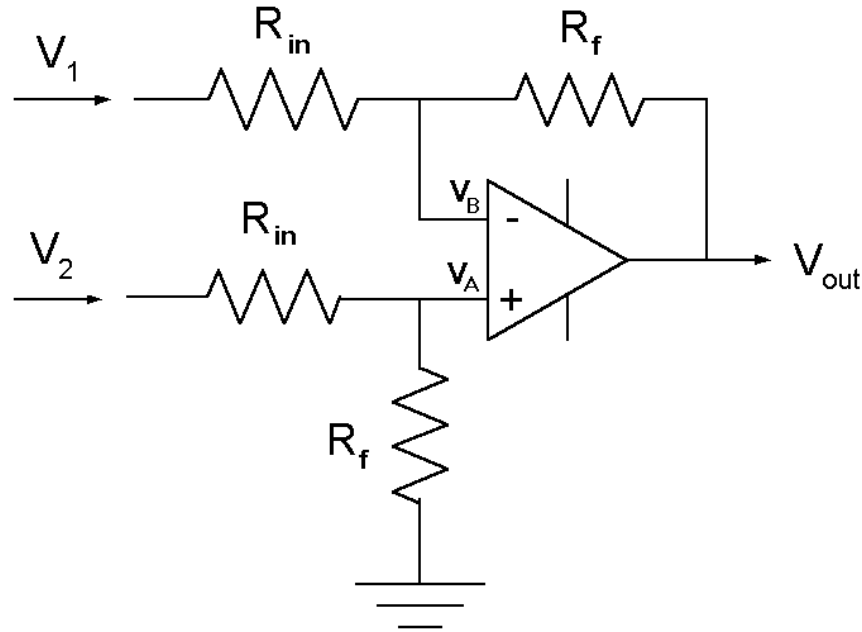
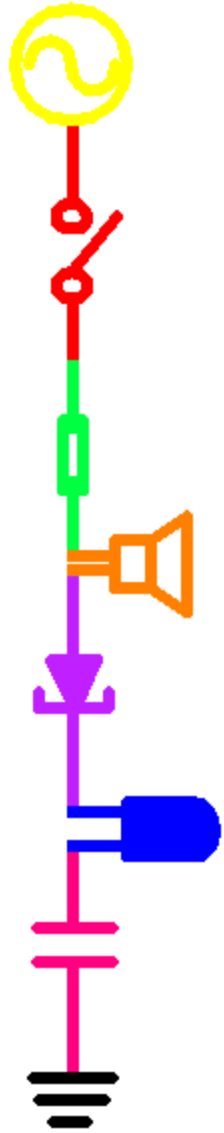

Analysis of Difference Amplifier(2)

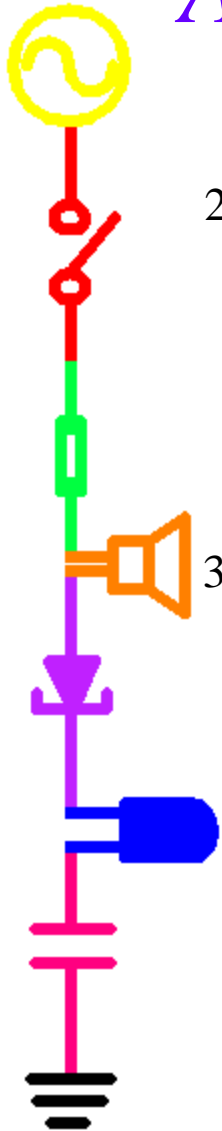

$$2) \quad -: \quad i = \frac{V_1 - V_B}{R_{in}} = \frac{V_B - V_{out}}{R_f}$$

$$+: \quad V_A = \frac{R_f}{R_{in} + R_f} V_2$$

Note that step 2(-) here is very much like step 2(-) for the inverting amplifier and step 2(+) uses a voltage divider.

$$3) \quad \text{solve for } V_B: \quad V_B = \frac{\frac{V_1}{R_{in}} + \frac{V_{out}}{R_f}}{\frac{1}{R_{in}} + \frac{1}{R_f}} \quad V_B = \frac{R_f V_1 + R_{in} V_{out}}{R_f + R_{in}} \quad V_B = \frac{R_f}{R_f + R_{in}} V_1 + \frac{R_{in}}{R_f + R_{in}} V_{out}$$

$$V_A = V_B: \quad \frac{R_f}{R_{in} + R_f} V_2 = \frac{R_f}{R_f + R_{in}} V_1 + \frac{R_{in}}{R_f + R_{in}} V_{out} \quad R_f V_2 - R_f V_1 = R_{in} V_{out}$$

$$\frac{V_{out}}{V_2 - V_1} = \frac{R_f}{R_{in}}$$

What would happen to this analysis if the pairs of resistors were not equal?

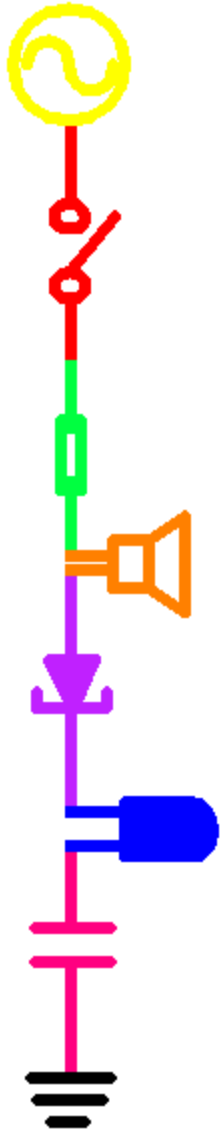

Op-Amp Limitations

- ◆ Model of a Real Op-Amp
- ◆ Saturation
- ◆ Current Limitations
- ◆ Slew Rate

Internal Model of a Real Op-amp

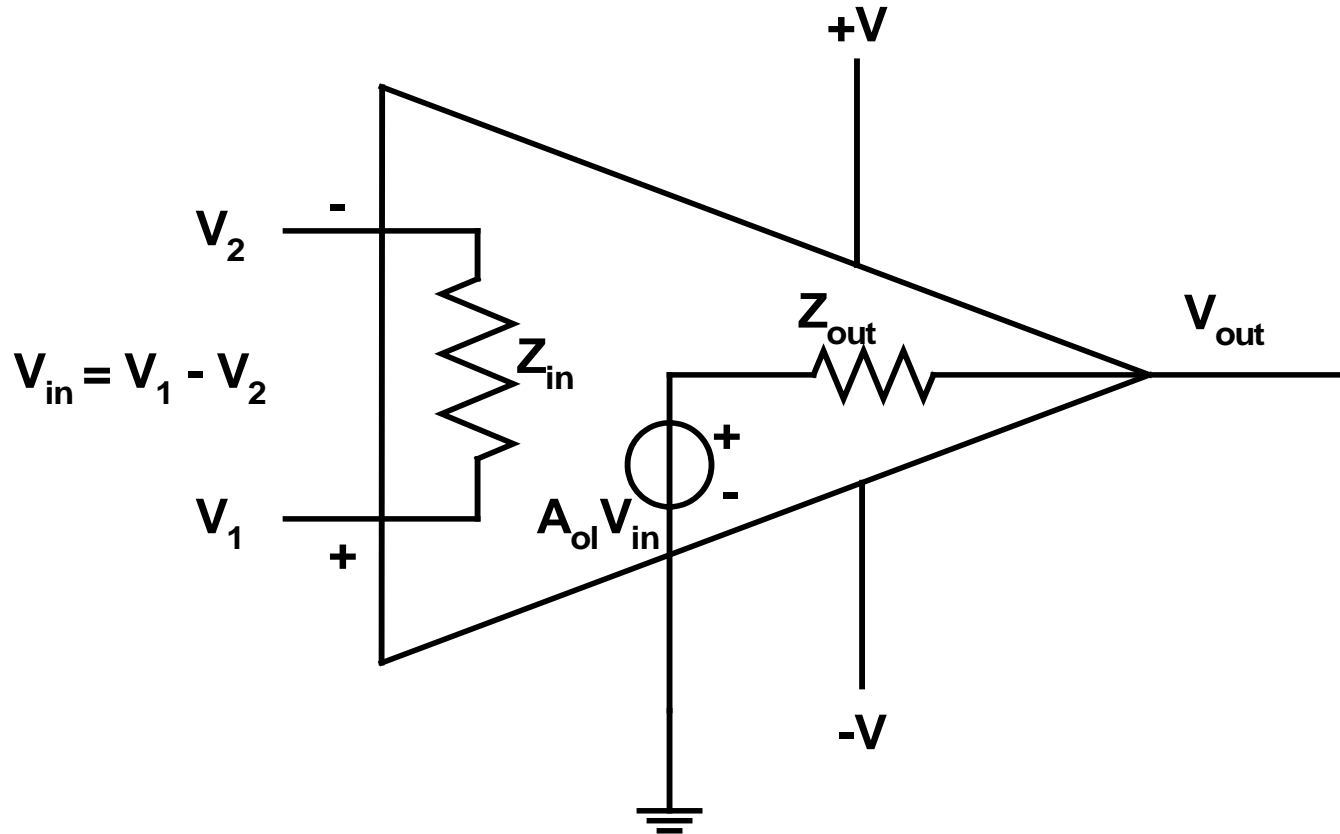
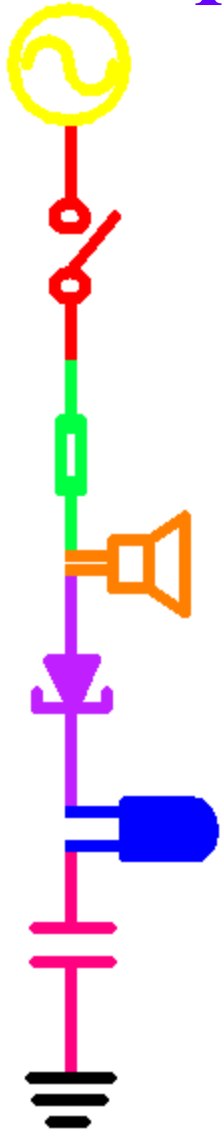

- Z_{in} is the input impedance (very large $\approx 2 \text{ M}\Omega$)
- Z_{out} is the output impedance (very small $\approx 75 \Omega$)
- A_{ol} is the open-loop gain

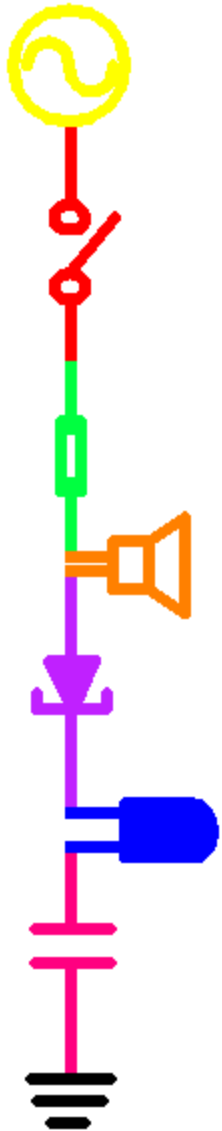

Saturation

- ◆ Even with feedback,
 - any time the output tries to go above V_+ the op-amp will saturate positive.
 - Any time the output tries to go below V_- the op-amp will saturate negative.
- ◆ Ideally, the saturation points for an op-amp are equal to the power voltages, in reality they are 1-2 volts less.

$$-V \leq V_{out} \leq +V$$

$$Ideal: -9V < V_{out} < +9V$$

$$Real: -8V < V_{out} < +8V$$

Additional Limitations

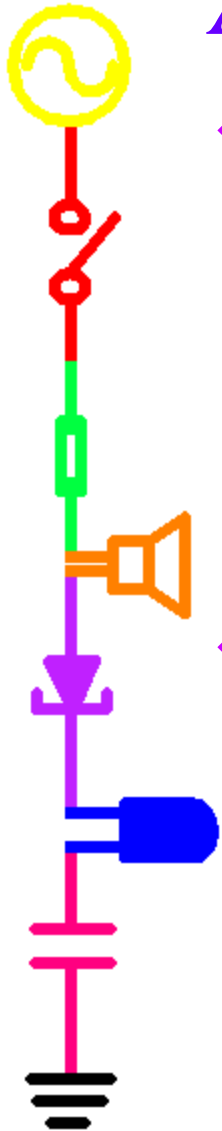

- ◆ Current Limits → If the load on the op-amp is very small,
 - Most of the current goes through the load
 - Less current goes through the feedback path
 - Op-amp cannot supply current fast enough
 - Circuit operation starts to degrade
- ◆ Slew Rate
 - The op-amp has internal current limits and internal capacitance.
 - There is a maximum rate that the internal capacitance can charge, this results in a maximum rate of change of the output voltage.
 - This is called the slew rate.



Analog Computers (circa. 1970)

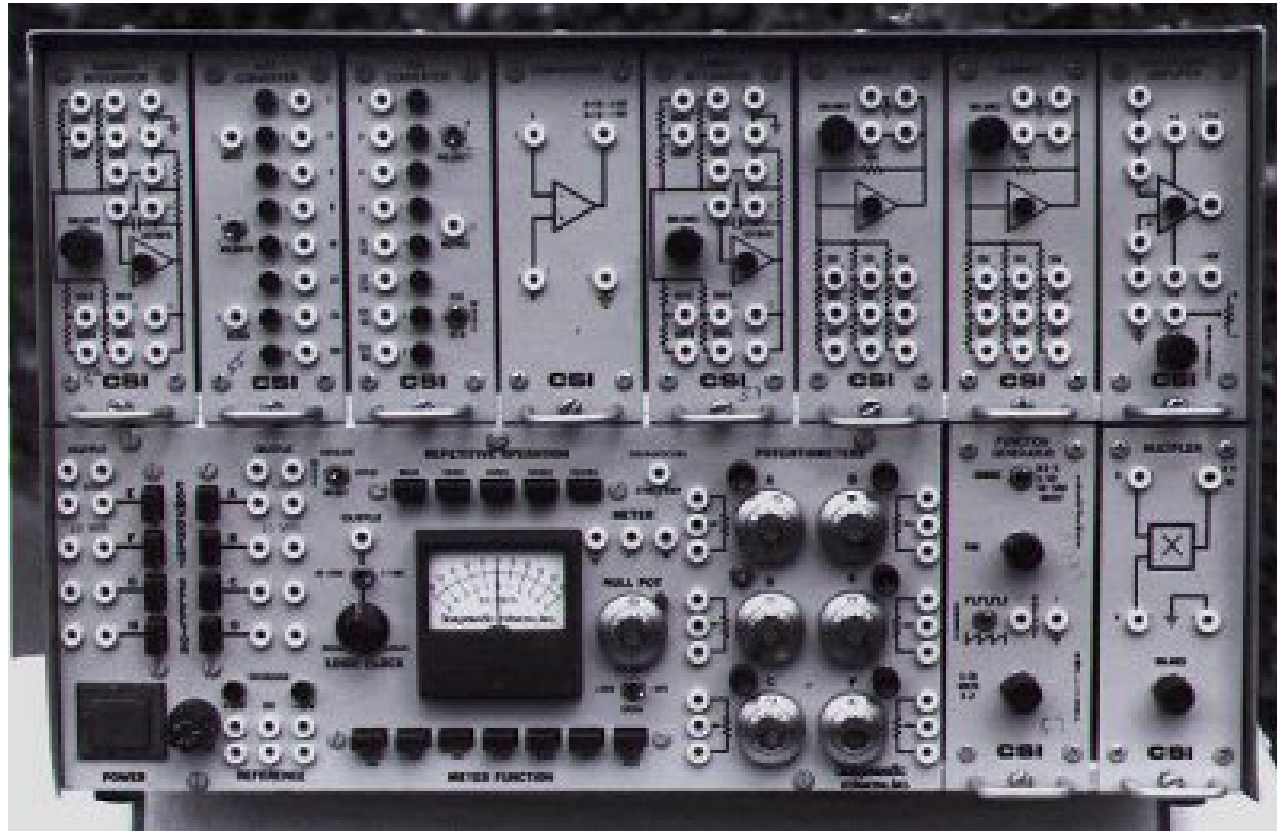

Analog computers use op-amp circuits to do real-time mathematical operations (solve differential equations).

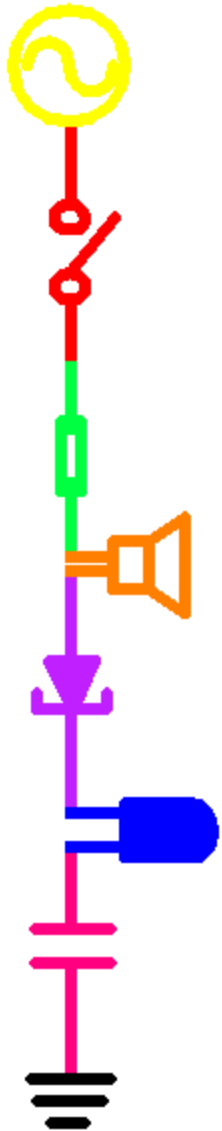

Using an Analog Computer

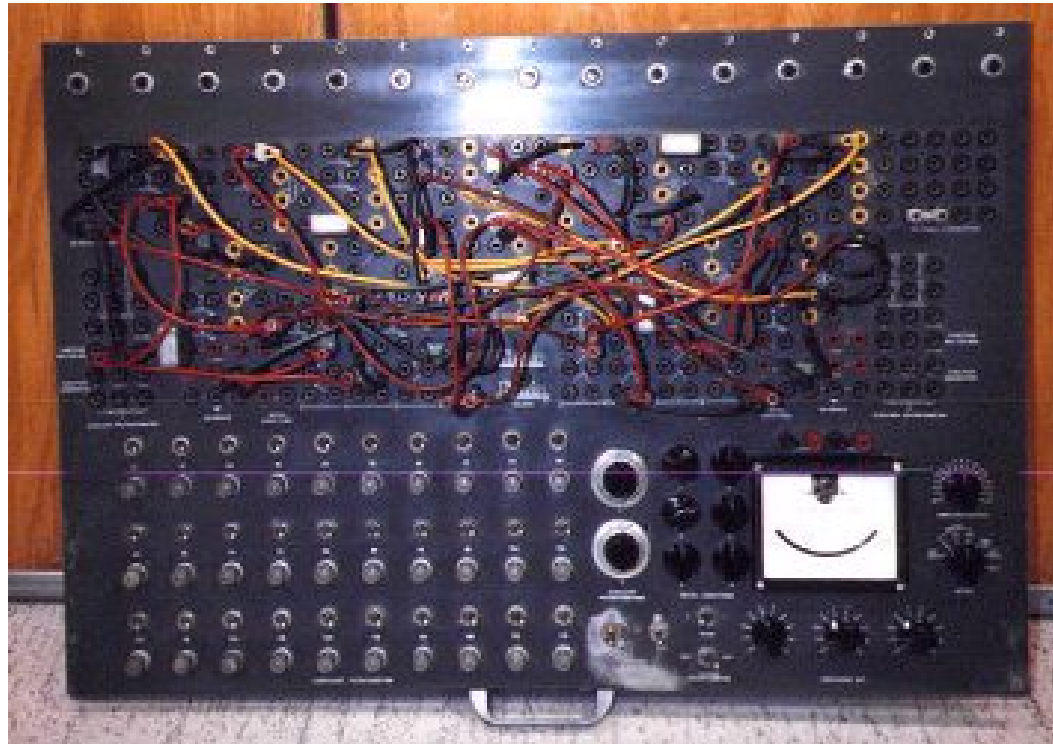

Users would hard wire adders, differentiators, etc. using the internal circuits in the computer to perform whatever task they wanted in real time.

Analog vs. Digital Computers

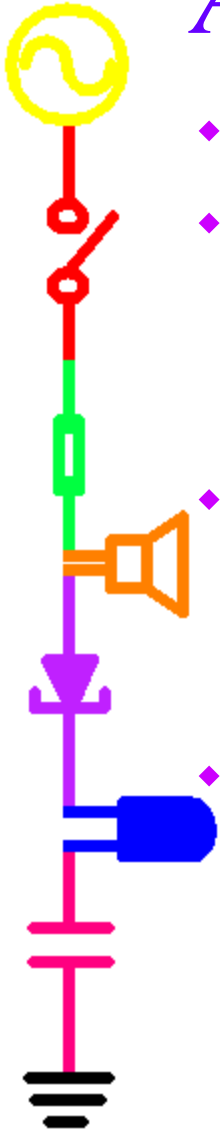

- ◆ In the 60's and 70's analog and digital computers competed.
- ◆ Analog
 - Advantage: real time
 - Disadvantage: hard wired
- ◆ Digital
 - Advantage: more flexible, could program jobs
 - Disadvantage: slower
- ◆ Digital wins
 - they got faster
 - they became multi-user
 - they got even more flexible and could do more than just math



Now analog computers live in museums
with old digital computers:

Mind Machine Web Museum: <http://userwww.sfsu.edu/%7Ehl/mmm.html>

Analog Computer Museum: <http://dcoward.best.vwh.net/analog/index.html>