

Name SOLUTIONS

1. \_\_\_\_\_ (6 pts)
2. \_\_\_\_\_ (15 pts)
3. \_\_\_\_\_ (8 pts)
4. \_\_\_\_\_ (8 pts)
5. \_\_\_\_\_ (8 pts)
6. \_\_\_\_\_ (10 pts)
7. \_\_\_\_\_ (5 pts)

Total \_\_\_\_\_

**For partial credit on some questions, you may want to re-draw/label circuit diagrams to clarify your answers.**

Show all of your work. Use the backs of pages if there is not enough room on the front.

Many problems can be solved using more than one method. Check your answers by using a second method.

At least skim through the entire quiz before you begin and then start with the problems you know best.

The proctor will only answer clarification questions where wording is unclear or where there may be errors/typos. No other questions will be responded to.

**Problem 1 (6 Points) – Voltage Dividers with a Sinusoidal Source**

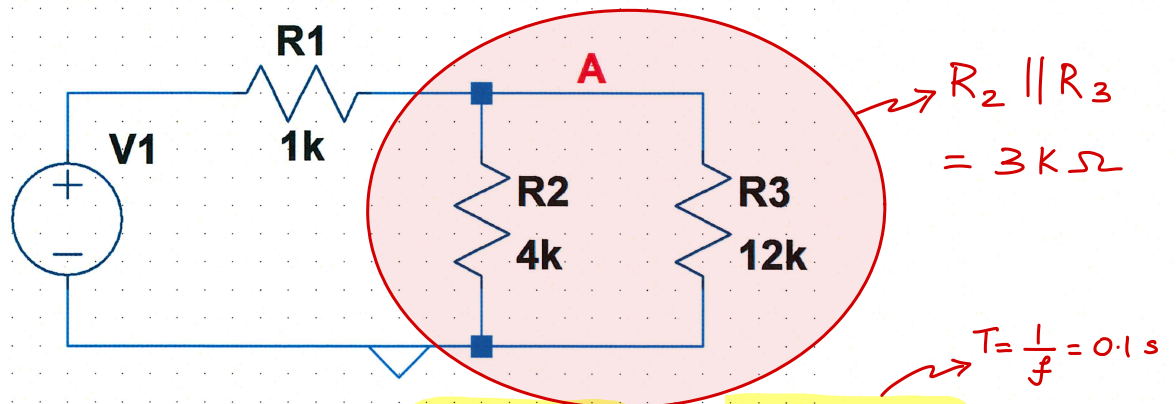

The source voltage is a sinusoidal signal, with an amplitude of 8V and a frequency of 10 Hz. On the provided plot, sketch the voltage at node A as a function of time.

Voltage @ node A,  $V_A = V_1 \left( \frac{3\text{K}}{1\text{K} + 3\text{K}} \right) = \frac{3}{4} V_1$

When  $V_1 = 8 \sin(2\pi 10t) \text{ V}$   
 $V_A = 6 \sin(2\pi 10t) \text{ V}$

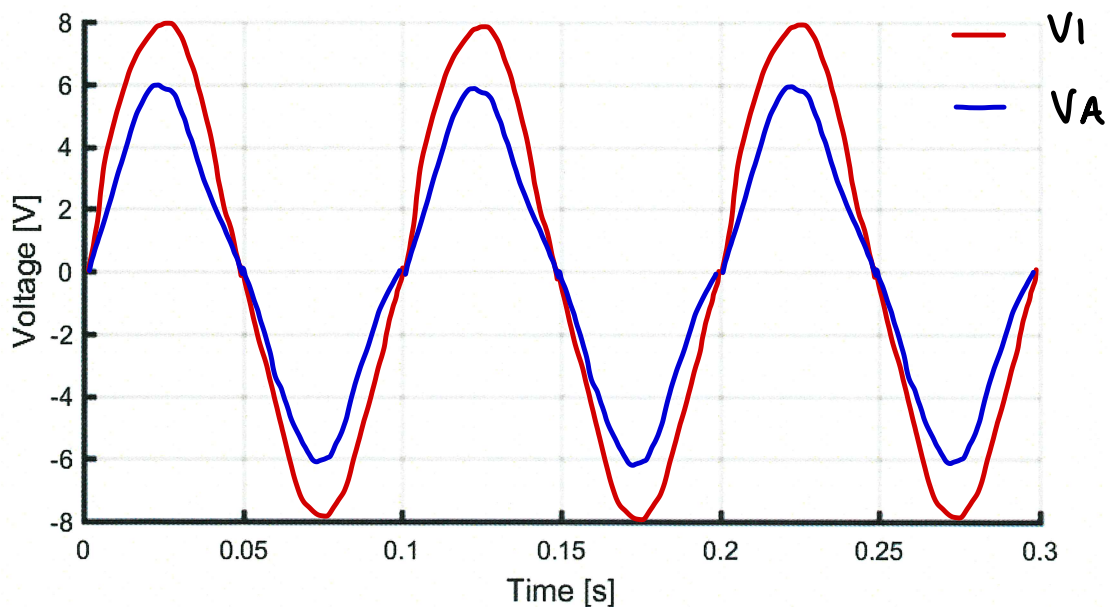

**Problem 2 (15 Points) – Nodal Analysis**

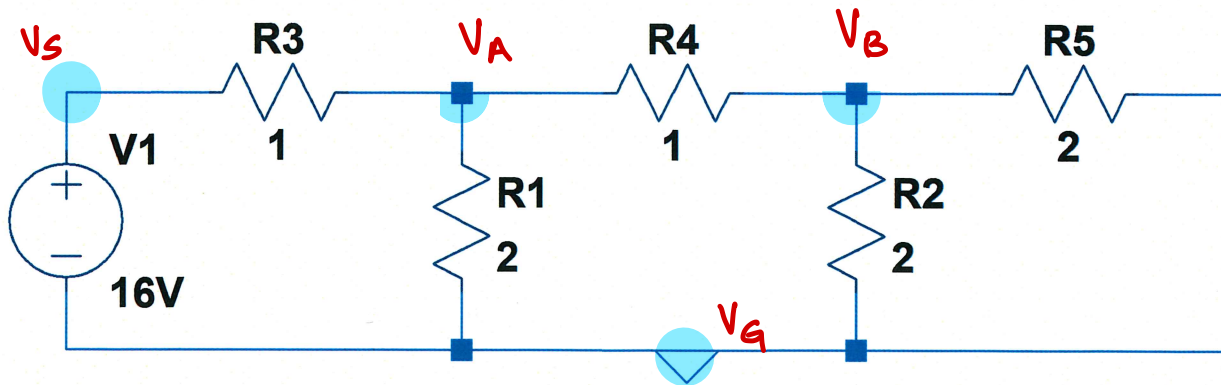

- a) Label all the nodes in the above circuit. (2 pts)
- b) Which labelled nodes have an unknown voltage? VA, VB (1 pt)
- c) Apply KCL and determine the linear system of equations associated with the unknown nodes. (Do not simplify the circuit using parallel and series relationships for resistors.) (3 pts)

KCL @ node A

$$\frac{V_A - 16}{1} + \frac{V_A}{2} + \frac{V_A - V_B}{1} = 0$$

$$\Rightarrow \frac{5}{2} V_A - V_B = 16 \quad \text{or} \quad \boxed{5V_A - 2V_B = 32}$$

KCL @ node B

$$\frac{V_B - V_A}{1} + \frac{V_B}{2} + \frac{V_B}{2} = 0$$

$$\Rightarrow \boxed{-V_A + 2V_B = 0}$$

Dependent equations are also acceptable

d) Based on your part c equations, build the matrix expression  $Ax = b$ . (2 pts)

$$\begin{bmatrix} 5 & -2 \\ -1 & 2 \end{bmatrix} \begin{bmatrix} V_A \\ V_B \end{bmatrix} = \begin{bmatrix} 32 \\ 0 \end{bmatrix}$$

Multiple forms possible; linearly dependent

e) Find the determinant of the  $A$  matrix in the above expression. (1 pts)

$$\det(A) = 10 - 2 = 8$$

Multiple answers possible based on matrix formulation

f) Using any method, find the inverse of the  $A$  matrix in the above expression. (2 pts)

$$A^{-1} = \frac{1}{\det(A)} \text{adj}(A) = \frac{1}{8} \begin{bmatrix} 2 & 2 \\ 1 & 5 \end{bmatrix}$$

$$= \begin{bmatrix} 0.25 & 0.25 \\ 0.125 & 0.625 \end{bmatrix}$$

depends on answer in part d

- g) Use matrix mathematics to determine the voltage at the unknown nodes. Circle your voltage results. (2 pts)

$$\begin{bmatrix} V_A \\ V_B \end{bmatrix} = \begin{bmatrix} 0.25 & 0.25 \\ 0.125 & 0.625 \end{bmatrix} \begin{bmatrix} 32 \\ 0 \end{bmatrix}$$

$$= \begin{bmatrix} 8 \\ 4 \end{bmatrix}$$

$$V_A = 8 \text{ V}$$

$$V_B = 4 \text{ V}$$

- h) If the source was replaced by a sinusoidal signal,  $V(t) = 16 \sin(20\pi t)$ , sketch the voltage at the unknown loads on the following plot. (2 pts)

$$f = 10 \text{ Hz} \Rightarrow T = 0.1 \text{ s}$$

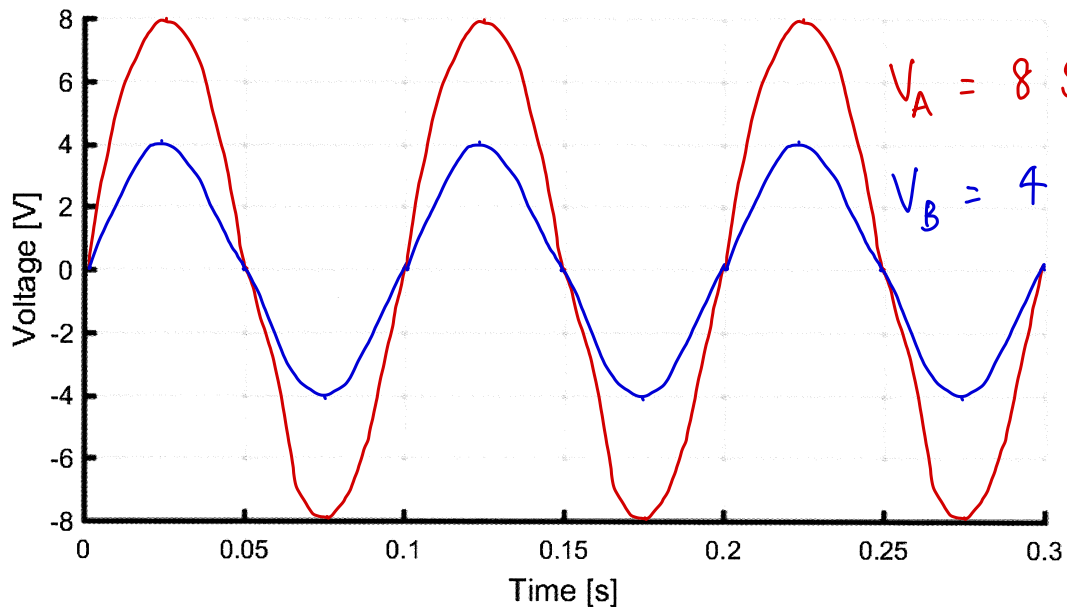

**Problem 3 (8 Points) – Concept Questions**

The voltage in an RC circuit when the capacitor is charging has which of the following expressions (circle one).

i.  $V(t) = V_o e^{-\frac{t}{RC}}$

ii.  $V(t) = V_o \left( 1 - e^{-\frac{t}{RC}} \right)$

The current in an RL circuit when the current is decaying has which of the following expressions (circle one).

i.  $I(t) = I_o e^{-\frac{t}{L/R}}$

ii.  $I(t) = I_o \left( 1 - e^{-\frac{t}{L/R}} \right)$

In an underdamped second order circuit, the relationship between the attenuation constant,  $\alpha$ , and the oscillation frequency,  $\beta$ , is (circle one)

i.  $\alpha > \beta$

ii.  $\alpha = \beta$

iii.  $\alpha < \beta$

We can increase the time constant in an RL circuit by (circle all correct answers)

i. Increasing the resistance

ii. Decreasing the resistance

iii. Increasing the inductance

iv. Decreasing the inductance

$$\tau = \frac{L}{R}$$



**Problem 4 (8 Points) – First Order Circuit**

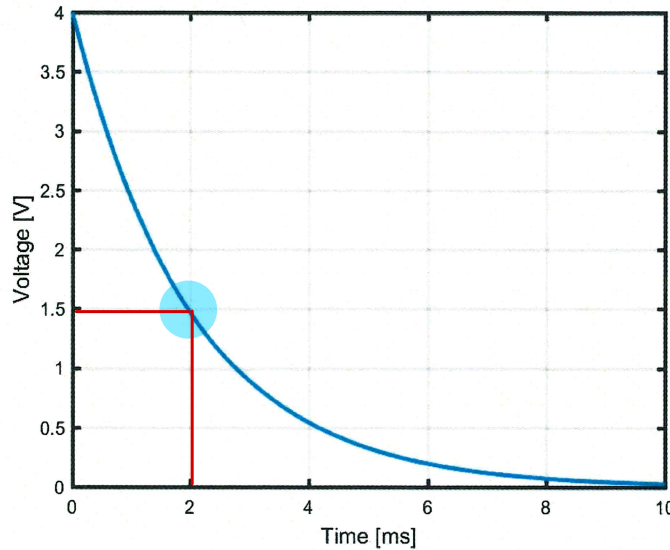

$\tau$  = time to discharge to 36.8% of 4V  
 $\Rightarrow$  Voltage at  $(t = \tau) = 4 \cdot e^{-1} = 1.47V$

- a) For the above plot, determine the time constant in ms. Note, the time axis is in units **milliseconds** (0.001s). (4 pts)

$\tau = 2ms$

$\tau$	$2$	[ms]
--------	-----	------

- b) Design any circuit that would produce the above voltage plot. Your circuit should include a source and include a brief description of how the source behaves. (4 pts)

Square wave with amplitude = 2V and offset = 2V time period = 20ms ( $f = 50Hz$ )

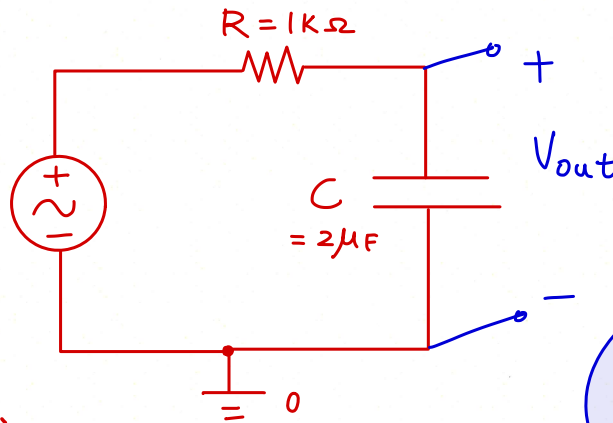
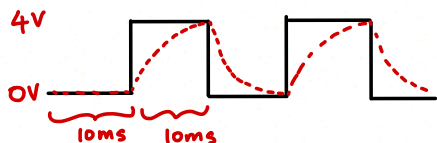

$\tau = 2ms = RC$   
 Let  $R = 1k\Omega$   
 $\Rightarrow C = 2\mu F$

Multiple correct answers possible as long as  $\tau = 2ms$

**Problem 5 (8 Points) – RC Circuits**

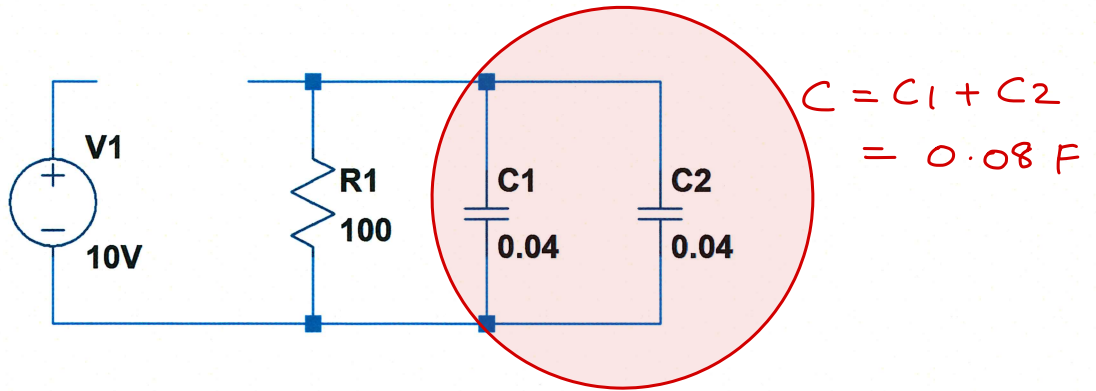

In the above circuit, the voltage source is connected to the circuit and then disconnected at  $t = 0s$  (time equals zero). Additionally, at  $t = 5s$ , capacitor  $C2$  is disconnected from the circuit, discharged by shorting the leads and then immediately reconnected to the circuit (all happening very quickly). To the best of your artistic ability, sketch the voltage across capacitor  $C1$  as a function of time.

For first 5 seconds  $\tau_1 = R_1 C = 8s$   
 $\Rightarrow V_0(t) = 10 e^{-t/\tau_1}$  @ 5s  $V_0(5) = 10 e^{-5/8} = 5.353 V$   
 $C_2$  discharged @  $t = 5 \Rightarrow V_0(t)$  is halved.  
 $\Rightarrow V_0(5^+) = 2.676 V$

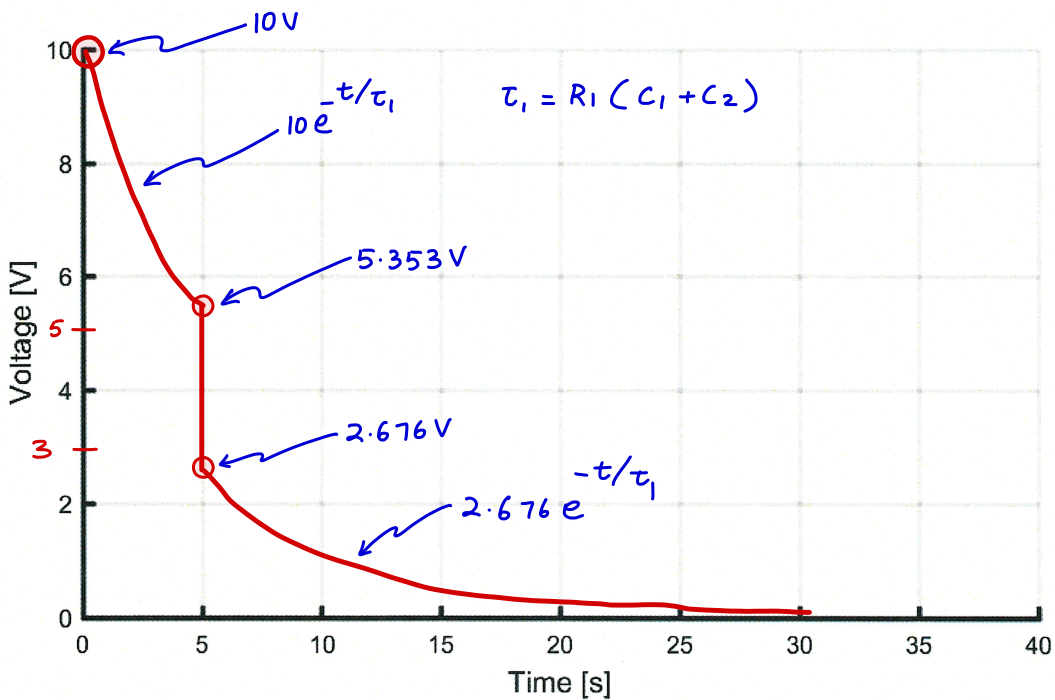



**Problem 6 (10 Points) – Second Order Circuit**

Note, the time axis is in units **seconds**.

- a) Estimate the DC steady state value of the voltage (the value of the voltage as time becomes very large). (2 pts)

10V

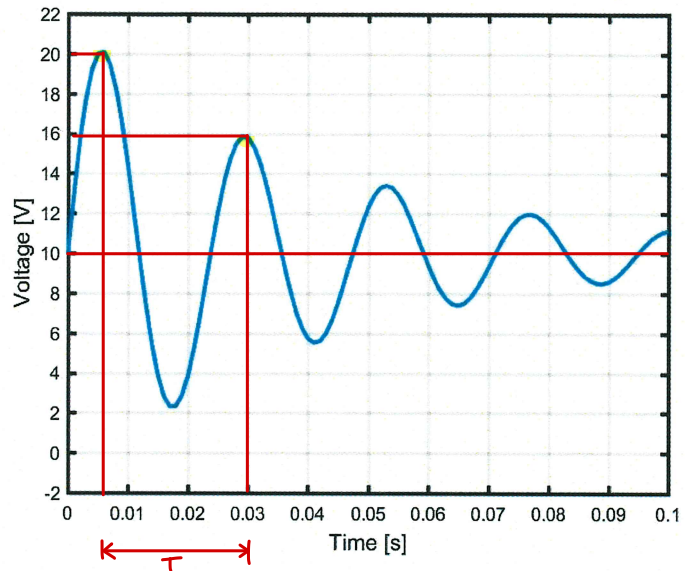

- b) Estimate the period, T, of the sinusoid. (2 pts)

$$T = 25 \text{ ms} \pm 2 \text{ ms accepted}$$

A more accurate value:

4.25 cycles in 0.1

$$\Rightarrow 1 \text{ cycle in } \frac{0.1}{4.25} = 23.53 \text{ ms}$$

- c) Estimate the oscillation frequency,  $\beta$ . (2 pts)

$$\beta = \frac{2\pi}{T} = 251.33 \text{ rad/s}$$

more accurate:  $\frac{2\pi}{23.53 \text{ ms}} = 267.03 \text{ rad/s}$

$\pm 10 \text{ rad/s}$   
accepted

- d) Estimate the attenuation constant,  $\alpha$ . (2 pts)

$$\alpha = - \frac{\ln \left( \frac{V_2 - V_{\text{offset}}}{V_1 - V_{\text{offset}}} \right)}{t_2 - t_1} = - \frac{\ln \left( \frac{6}{10} \right)}{25 \text{ ms}} = 20.43 \text{ rad/s}$$

$\pm 5 \text{ rad/s}$   
accepted

- e) Estimate the resonant frequency,  $\omega_0$ . (2 pts)

$$\omega_0 = \sqrt{\beta^2 + \alpha^2} = \sqrt{267.03^2 + 20.43^2} = 267.81 \text{ rad/s}$$

$\pm 10 \text{ rad/s}$   
accepted.

**Problem 7 (5 Points) – Second Order Circuit**

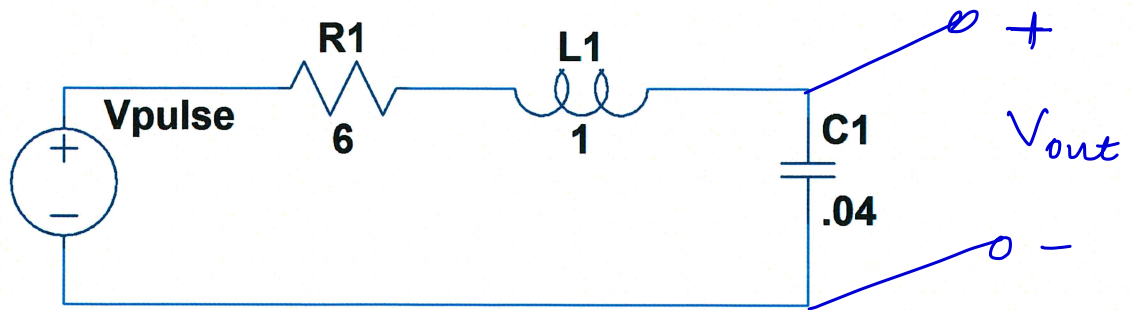

To the best of your artistic ability, sketch the voltage across the capacitor in the above circuit for a pulsed voltage source, between  $V_{min} = 0V$  and  $V_{max} = 5V$ . You only need to sketch one 'section' of the decaying sinusoid during capacitor discharge (when the capacitor voltage is decaying to zero). Annotate your plot, indicating 'features of interest'.

Resonant frequency,  $\omega_0 = \frac{1}{\sqrt{LC}} = 5 \text{ rad/s}$

Attenuation constant,  $\alpha = \frac{R}{2L} = 3 \text{ rad/s}$

Damped oscillation frequency,  $\beta = \sqrt{\omega_0^2 - \alpha^2} = 4 \text{ rad/s}$

$$V_{out} = 5 e^{-3t} \cos(4t) \text{ Volts}$$

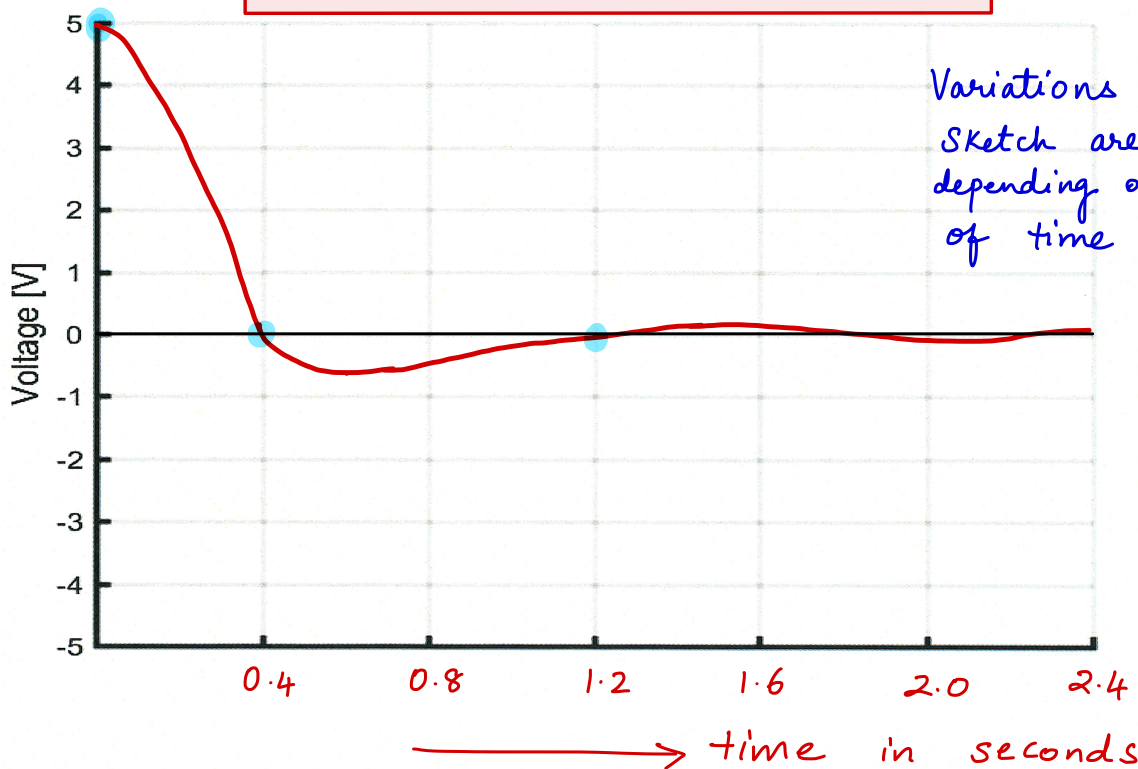

Variations of sketch are acceptable depending on choice of time axis.