

Name \_\_\_\_\_

1. \_\_\_\_\_ (12 pts)
2. \_\_\_\_\_ (8 pts)
3. \_\_\_\_\_ (8 pts)
4. \_\_\_\_\_ (14 pts)
5. \_\_\_\_\_ (8 pts)

Total \_\_\_\_\_

**For partial credit on some questions, you may want to re-draw/label circuit diagrams to clarify your answers.**

Show all of your work. Use the backs of pages if there is not enough room on the front.

Many problems can be solved using more than one method. Check your answers by using a second method.

At least skim through the entire quiz before you begin and then start with the problems you know best.

The proctor will only answer clarification questions where wording is unclear or where there may be errors/typos. No other questions will be responded to.

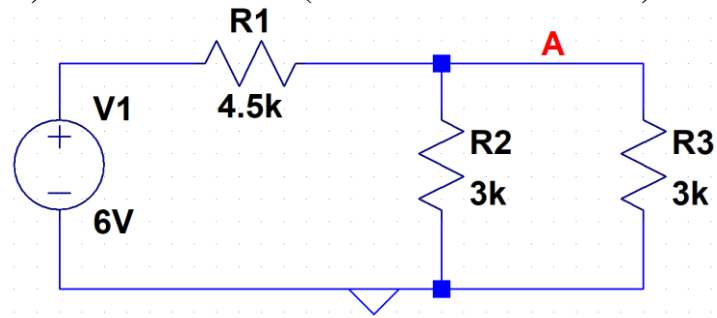
**Problem 1 (12 Points) – Ladder Circuits (Parallel/Series Resistors)**

- a) Using parallel, series and/or voltage divider concepts, determine the voltage at node A. (4 pts)

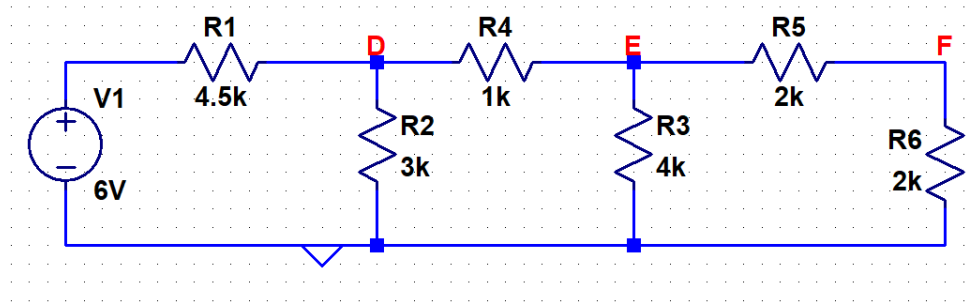

- b) Using parallel, series and/or voltage divider concepts, determine the voltage at nodes D, E, and F. Don't make any assumptions based on previous circuits without verifying those assumptions. You can include schematics of circuit reduction techniques for partial credit. (8 pts)

**Problem 2 (8 Points) – Concept Questions**

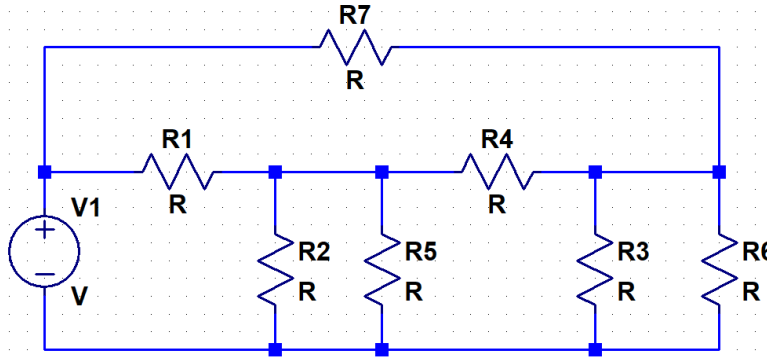

- a) How many nodes are in the above circuit? (You might want to label them for partial credit) (2 pts)

Number of nodes	
-----------------	--

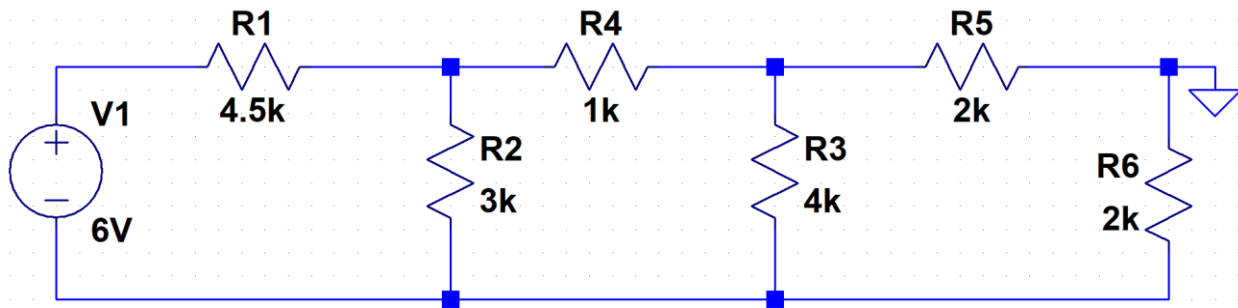

- b) The above circuit is the same circuit seen at the end of problem 1, except the ground node has been moved. Determine the voltage across resistor R6. (2 pts)

Voltage across R6	[V]
-------------------	-----

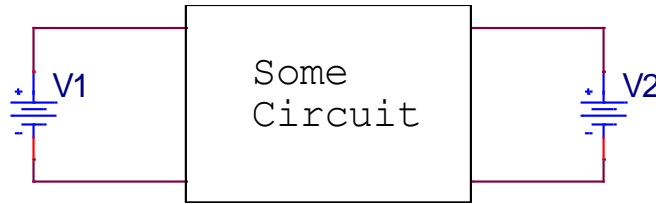

Two voltage sources are connected to some linear circuit. The voltage at V2 was set to zero and the voltage V1 was swept from 0 to 5V. The voltage at some node A inside the circuit was measured and the plot of  $V_A$  vs. V1 (with  $V_2 = 0$ ) is shown below.

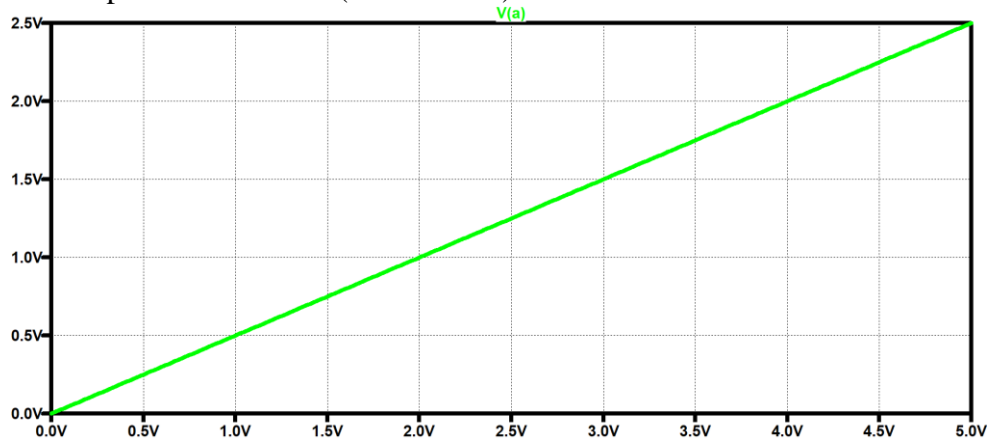

Similarly, the voltage at V1 was set to zero and the voltage V2 was swept from 0 to 5V. The voltage at some node A inside the circuit was measured and the plot of  $V_A$  vs. V2 (with  $V_1 = 0$ ) is shown below.

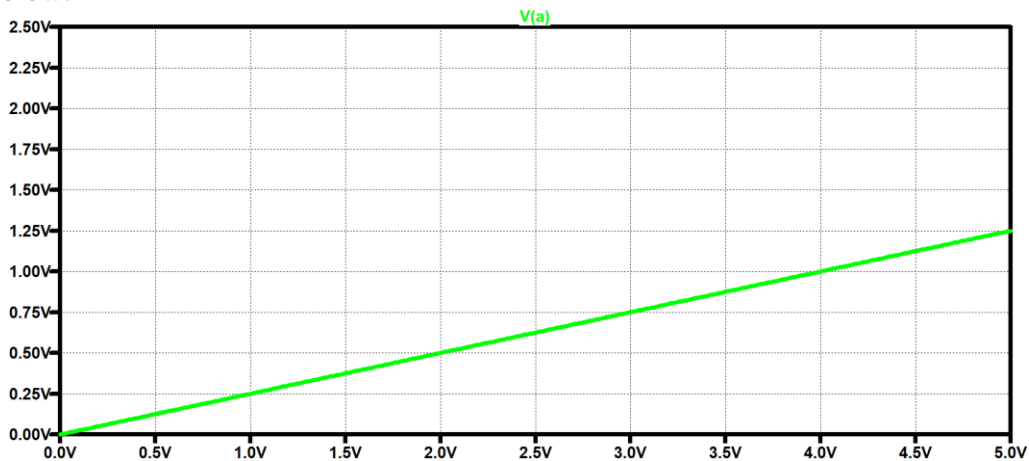

- c) Based on the above results for the two source circuit, express the voltage at node A in the form,  $V_A = aV_1 + bV_2$ . In other words, for values for the constants  $a$  and  $b$ . (4 pts)

$$V_A = \underline{\hspace{2cm}} V_1 + \underline{\hspace{2cm}} V_2$$

**Problem 3 (8 Points) – Matrix Solutions**

$$\begin{bmatrix} 1 & 2 & 0 \\ -1 & 0 & 1 \\ 0 & 1 & 1 \end{bmatrix} \begin{bmatrix} x_1 \\ x_2 \\ x_3 \end{bmatrix} = \begin{bmatrix} 1 \\ 1 \\ 2 \end{bmatrix}$$

Using techniques applied in the laboratories, solve for the unknown values in the above matrix expression. You must show your work by filling in the matrix fields. There are likely more fields than you need.

Matrix reduction: (4 pts)

$$\begin{bmatrix} & & \\ & & \\ & & \end{bmatrix} \begin{bmatrix} x_1 \\ x_2 \\ x_3 \end{bmatrix} = \begin{bmatrix} \\ \\ \end{bmatrix}$$

Step 1

$$\begin{bmatrix} & & \\ & & \\ & & \end{bmatrix} \begin{bmatrix} x_1 \\ x_2 \\ x_3 \end{bmatrix} = \begin{bmatrix} \\ \\ \end{bmatrix}$$

Step 2

$$\begin{bmatrix} & & \\ & & \\ & & \end{bmatrix} \begin{bmatrix} x_1 \\ x_2 \\ x_3 \end{bmatrix} = \begin{bmatrix} \\ \\ \end{bmatrix}$$

Step 3

$$\begin{bmatrix} & & \\ & & \\ & & \end{bmatrix} \begin{bmatrix} x_1 \\ x_2 \\ x_3 \end{bmatrix} = \begin{bmatrix} \\ \\ \end{bmatrix}$$

Step 4

Solving for  $x_1, x_2, x_3$  (4 pts)

**Problem 4 (14 Points) – Nodal Analysis**

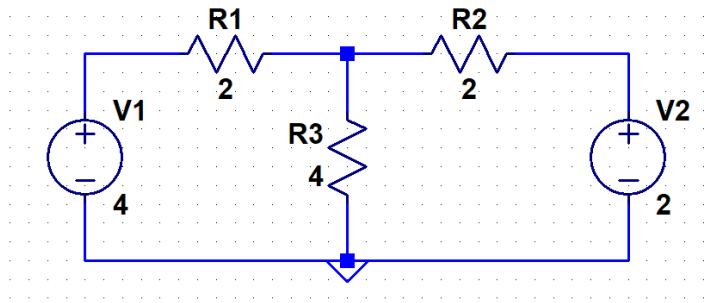

- a) Label all the nodes in the above circuit. (1 pts)
- b) Based on your labels, which node has a voltage of 0V? (1 pt)

Ground Node	
-------------	--

- c) Due to voltage sources, which nodes have known voltages and what are those voltages? (1 pt)

	[V]
	[V]

- d) Determine the voltage at the unknown node. (3 pts)

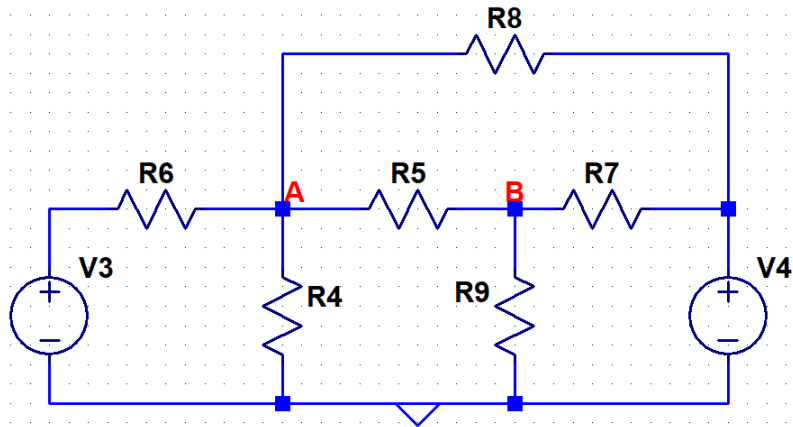

e) Use nodal analysis to find the matrix equation,  $Ax = b$ . All your terms should be symbolic (no numbers needed) (8 pts)

$$\begin{bmatrix} \phantom{0} \\ \phantom{0} \end{bmatrix} \begin{bmatrix} \phantom{0} \\ \phantom{0} \end{bmatrix} \begin{bmatrix} V_A \\ V_B \end{bmatrix} = \begin{bmatrix} \phantom{0} \\ \phantom{0} \end{bmatrix}$$

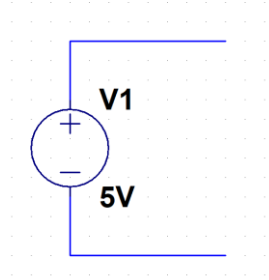

**Problem 5 (8 Points) – Design Problems**

- a) Design a circuit such that there is a node with voltage 1V. Finish the circuit using the above source voltage. (4 pts)
- b) Design any circuit (any combination of resistors and source voltages) that has a node with 4V and a node with 1V. Neither of those nodes can be connected to a voltage source. (4 pts)