

Intro to ECSE

Quiz 2

Fall 2024

1.	/12
2.	/8
3.	/13
4.	/12
Total	/45

Name _____

RIN _____

Notes:

SHOW ALL WORK. BEGIN WITH FORMULAS, THEN SUBSTITUTE VALUES AND UNITS. No credit will be given for numbers that appear without justification.

Use the backs of pages if there is not enough room on the front.

For partial credit on some questions, you may want to re-draw circuit diagrams as you simplify the circuits.

Many problems can be solved using more than one method. check your answers by using a second method.

At least skim through the entire quiz before you begin and then start with the problems you know best. The proctor will only answer clarification questions where wording is unclear or where there may be errors/typos. No other questions will be responded to.

Problem 1 [12 Points]: Miscellaneous Concepts and Short Answer Questions

1.1 [4 pts] Sketch the IV characteristic for a resistor with $R = 2000\Omega$ for the range $-1V < V < 1V$. Label the axes of the IV characteristic with numerical values for I and V and indicate the slope of the IV characteristic.

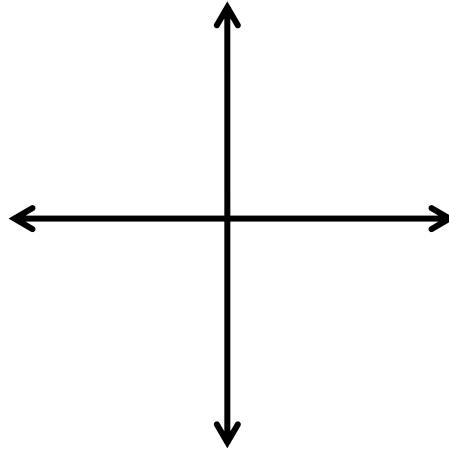

1.2 [2 pts] The transfer characteristic for an amplifier circuit is shown to the right. What type of amplifier is this? What is its gain?

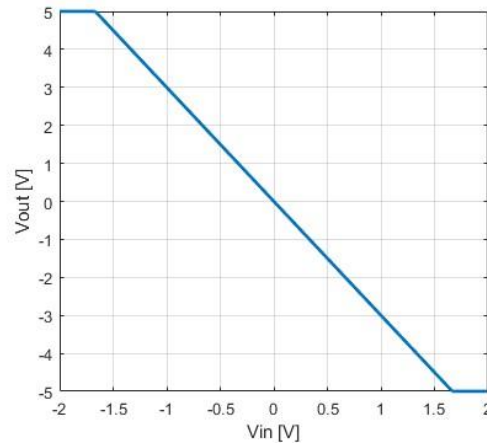

Amplifier Type:

Gain:

1.3 [2 pts] The IV characteristic for a diode is shown to the right. What is the turn on voltage? What is the reverse breakdown voltage?

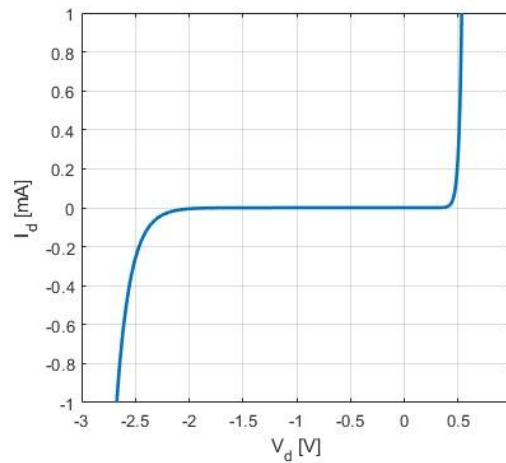

Turn-on Voltage:

Reverse Breakdown Voltage:

1.4 [2 pts] *True or False*: transfer functions can only be derived for linear systems. Circle one:

True

False

1.5 [2 pts] As we discussed in class, dependent sources are not real components that can be used to build a physical circuit. If that's the case, what is the purpose of including dependent sources in circuit schematics?

Problem 2 [8 Points]: Superposition

Solve for V_{R1} , the voltage across $R1$, in the circuit below *using the superposition method* of circuit analysis.

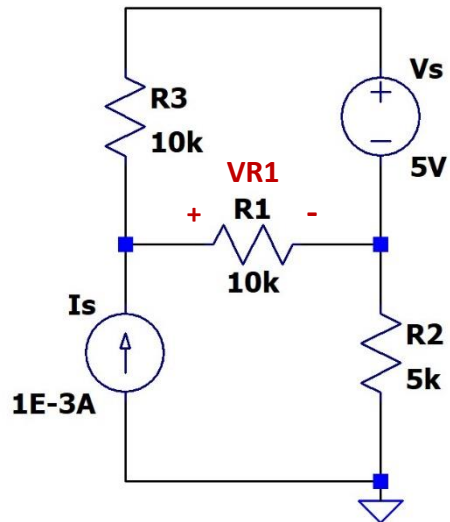

- a. [3 pts] Find $V_{R1}(V_s)$, the voltage across $R1$ due to V_s only.

$V_{R1}(V_s)$:

b. [3 pts] Find $V_{R1}(I_s)$, the voltage across R1 due to I_s only.

$V_{R1}(I_s)$:

c. [2 pts] Using $V_{R1}(V_s)$ and $V_{R1}(I_s)$, find V_{R1} as indicated in the circuit above.

V_{R1} :

Problem 3 [13 Points]: Nodal Analysis

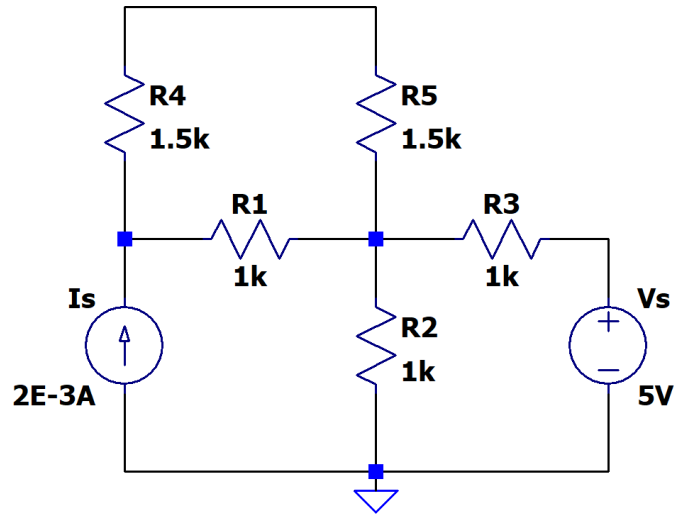

- a. [2 pts] How many voltage nodes in total (both known and unknown) are in this circuit? Label them on the circuit schematic.

**Total Number
of Nodes:**

- b. [2 pts] Which of these nodal voltages are already known (if any)? Write their numerical values on the circuit schematic.

- c. [2 pts] How many linearly independent equations are needed to solve for all unknowns in this circuit?

**Total Number
of Equations Needed:**

- d. [3 pts] Write down the KCL equation for each node in terms of the nodal voltages you labeled on the schematic in 1.a and 1.b.

KCL Equations:

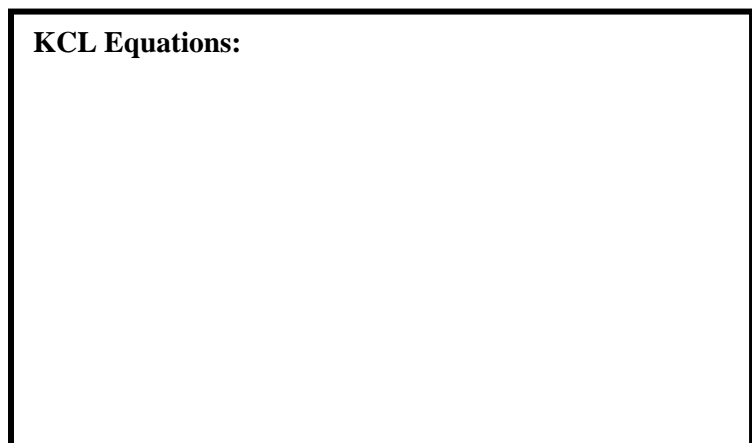

- e. [4 pts] Write the equations from 1.d in matrix form with numerical values for circuit elements inserted (i.e. numbers for all resistances, known voltages, and known currents). You do not need to numerically solve the matrix equation.

Matrix A =

$$\left[\begin{array}{c} \\ \\ \\ \end{array} \right]$$

Vector x =

$$\left[\begin{array}{c} \\ \\ \end{array} \right]$$

Vector b =

$$\left[\begin{array}{c} \\ \\ \end{array} \right]$$

Problem 4 [12 Points]: Cascaded Op-Amp Circuit

Determine the value of V_{out} . The supply voltages V_{s+} and V_{s-} for the op-amps are $+9V$ and $-9V$.

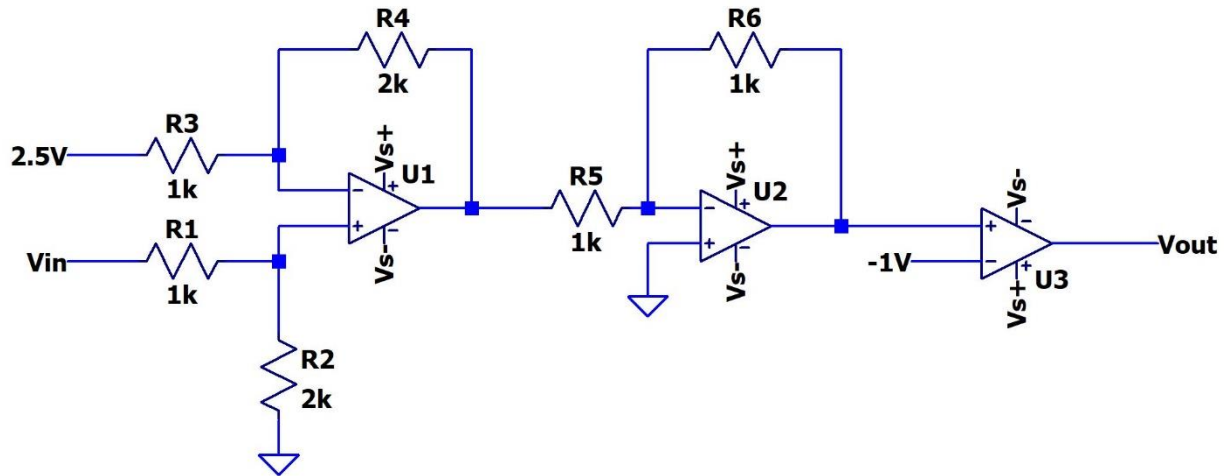

- [3 pts] Identify how many stages are in this op-amp circuit. Draw a box around each stage and label them "Stage 1", "Stage 2", etc.
- [3 pts] Label each stage of the circuit with what type of circuit it is. *Note:* for all stages, specify if it is "non-inverting" or "inverting" when applicable.

- c. [3 pts] For each stage, write the transfer function as a numerical value. In cases in which a transfer function cannot be written for a stage, state this clearly, and write the expression for the output voltage of that stage in terms of the input voltage instead. *Hint:* V_{in} for a stage may be the sum or difference of two voltages; in this case, also state what you consider to be V_{in} for that stage.

Transfer function for each stage:

- d. [3 pts] Calculate V_{out} for $V_{in} = 4V$.

V_{out} :