

ECSE 1010: Intro to ECSE

Quiz 2 (10% of overall grade)

18th October, 2021

Name: _____

RIN #: _____

General Instructions

1. This exam is open-book, open-notes. You are allowed a non-communicating calculator.
2. You are not allowed to use your Laptop/iPad during the quiz.
3. If you need extra space, use an empty sheet of paper, and insert it below the problem.
4. If you need to make any assumptions to answer a question, state them clearly.
5. **Please show all your work!**

Question #	Possible Points
1: M1K Instrumentation and Alice Tools	15
2: Design Problems	15
3: Nodal Analysis	20
4: Resistive Circuits	10
5: Nodal Analysis – Multiple Sources	15
Total	75

Problem 1. (15 points) M1K Instrumentation and Alice Tools

You are asked to experimentally determine the current through resistor R3 in the circuit diagram shown below. You decide to setup the circuit on a protoboard and use M1K to supply the voltages and make voltage measurements at node A and node B.

Note: You are not going to be determining the numerical value of the current in this problem. Instead, in the following questions, you will be describing the experimental setup, software configuration, and a way to analyze the results that will help determine current through R3.

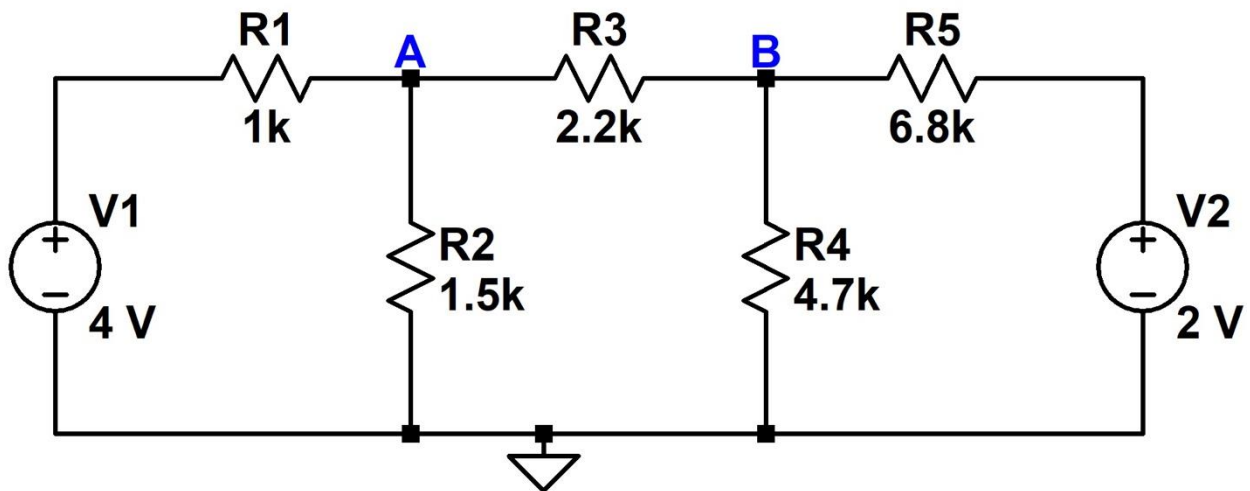

Part a) (2 points) Which Alice tool would be best suited for this experiment?
Circle your answer.

- I. Alice Voltmeter
- II. Alice Meter-Source
- III. Alice Desktop
- IV. Alice Ohmmeter
- V. Alice Data-logger
- VI. Alice Strip Chart

Part b) (5 points) Shown below are the M1K board pinouts, empty protoboard (like the one in your parts kit but half the size), and resistors R1 to R5. Clearly draw lines between M1K, protoboard, and resistors to represent all the wires you need to connect to determine the nodal voltages at point A and B. Indicate the holes being used on the protoboard by completely blackening the circles.

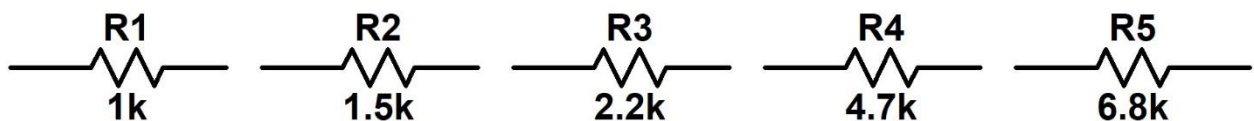
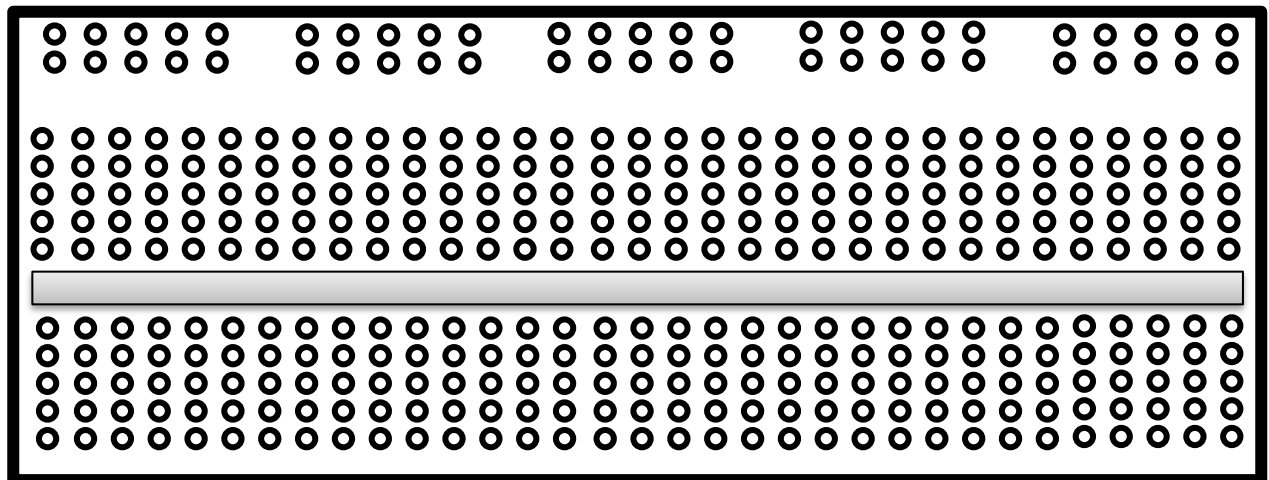
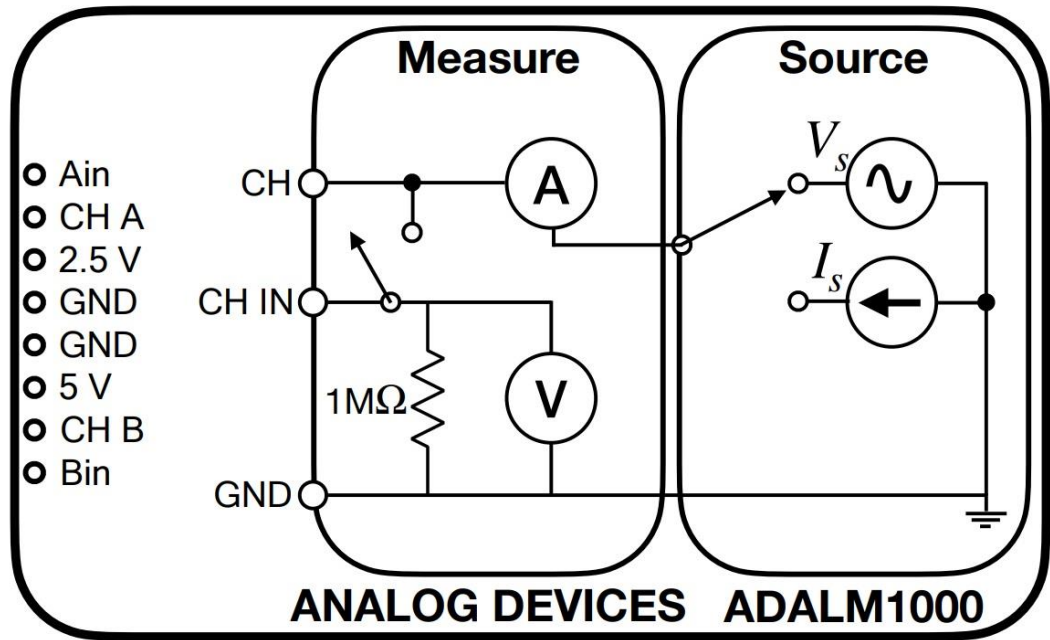

Part c) (5 points) Configuring the Software

After setting up the circuit, you would need to launch Alice tools and setup the application. What are the changes you would make in this default view of the Alice tool shown below? Circle the item you would change and write down what you would change it to. Also point out where the desired voltage measurements would be displayed. As an example, the last step of clicking the Run button is answered. Use the space around the figure as needed to label changes.

Click here to start supplying voltages and acquiring measurements.

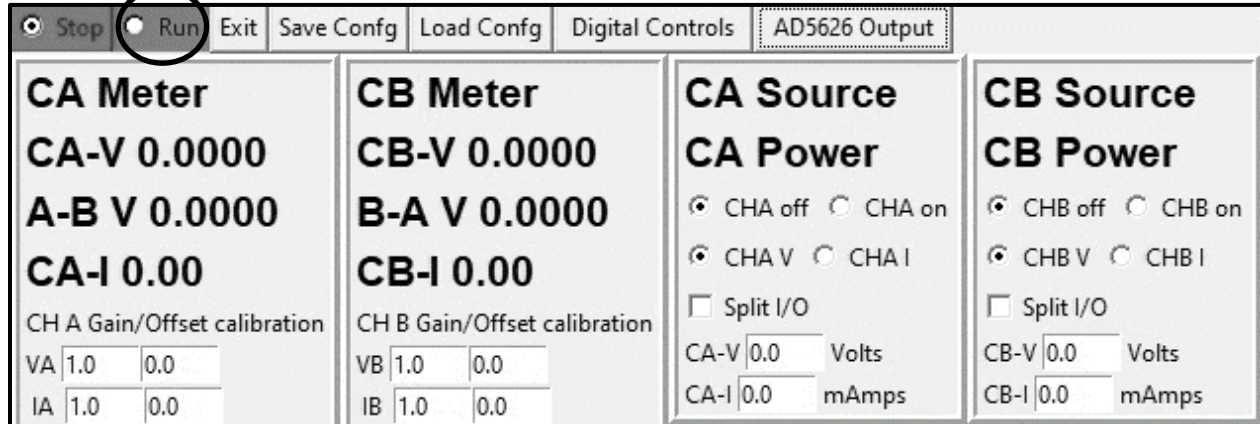

The screenshot shows the Alice tool interface with the following sections:

- Buttons:** Stop, Run (circled), Exit, Save Config, Load Config, Digital Controls, AD5626 Output
- CA Meter:** CA-V 0.0000, A-B V 0.0000, CA-I 0.00. Calibration: CH A Gain/Offset calibration (VA: 1.0, 0.0; IA: 1.0, 0.0)
- CB Meter:** CB-V 0.0000, B-A V 0.0000, CB-I 0.00. Calibration: CH B Gain/Offset calibration (VB: 1.0, 0.0; IB: 1.0, 0.0)
- CA Source:** CA Power. CHA off (selected), CHA on. CHA V (selected), CHA I. Split I/O (unchecked). CA-V 0.0 Volts, CA-I 0.0 mAmps.
- CB Source:** CB Power. CHB off (selected), CHB on. CHB V (selected), CHB I. Split I/O (unchecked). CB-V 0.0 Volts, CB-I 0.0 mAmps.

Part d) (3 points) Analyzing the results.

From the nodal voltages obtained using the Alice tool above, explain how you would use this data to determine current through R3. Comment about how you would determine the direction of this current.

Problem 2. (15 points) Design Problems

For the three design problems below, your answers should include a clearly drawn schematic of the circuit and should also include work/explanation justifying your design methodology. Indicate which node/nodes satisfy the design criterion.

Part a) (4 points) Design a circuit such that there is a node with voltage 3 V. Constraint: Use one voltage source of value 9 V.

Part b) (5 points) Design a circuit (any combination of resistors and source voltages) that has a node with 3.75 V and a node with 1.25 V. Neither of those nodes can be connected to a voltage source.

Part c) (6 points) Design a circuit such that there is a node with voltage 5 V. Constraint: Use two voltage sources of values 9 V and 12 V and three resistors. None of the resistors should be in parallel or series with each other.

Problem 3. (20 points) Nodal Analysis

Consider the circuit shown below.

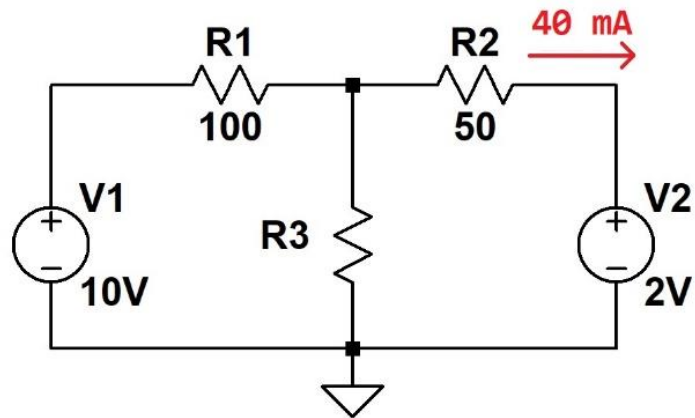

Part a) (10 points) Determine the value of resistance R3 using nodal analysis such that the current through R2 is 40 mA as shown. Show handwritten work.

Consider a new circuit shown below. Answer part b based on new circuit.

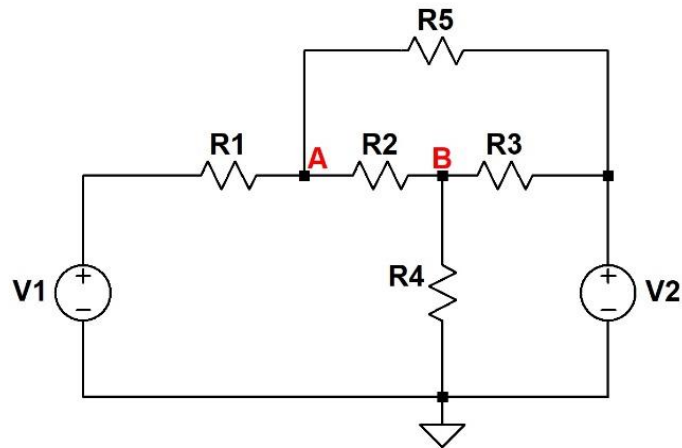

Part b (10 points) Use nodal analysis to find the matrix equation, $A\mathbf{x} = \mathbf{b}$. All your terms should be symbolic (no numbers needed). Your final answer should be expressed as a matrix equation as shown below. V_A and V_B are nodal voltages at nodes A and B respectively.

$$\left[\begin{array}{c} \\ \end{array} \right] \begin{bmatrix} V_A \\ V_B \end{bmatrix} = \begin{bmatrix} \\ \end{bmatrix}$$

Problem 4. (10 points) Resistive Circuits

Consider the circuit diagram shown.

$$V_1 = 40V,$$

$$R_1 = R_4 = R_5 = R_6 = 1 \text{ kilo-ohm}$$

$$R_2 = R_3 = 2 \text{ kilo-ohms}$$

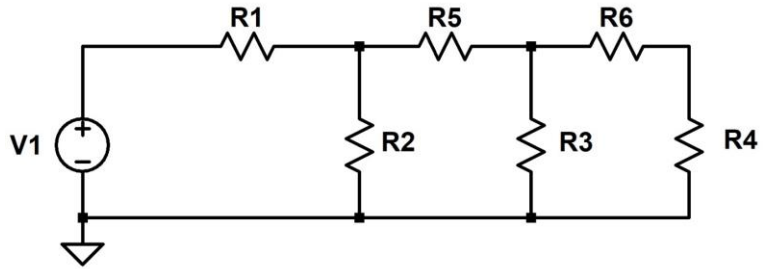

Part a) (3 points) Find the total resistance of the circuit, seen from the voltage source.

Part b) (4 points) Find the voltages across R_1 and R_4 .

Part c) (3 points) Find the currents through R_2 and R_3 .

Problem 5. (15 points) Nodal Analysis – Multiple Sources

Use KCL and nodal analysis to answer this problem. Consider the circuit shown below.

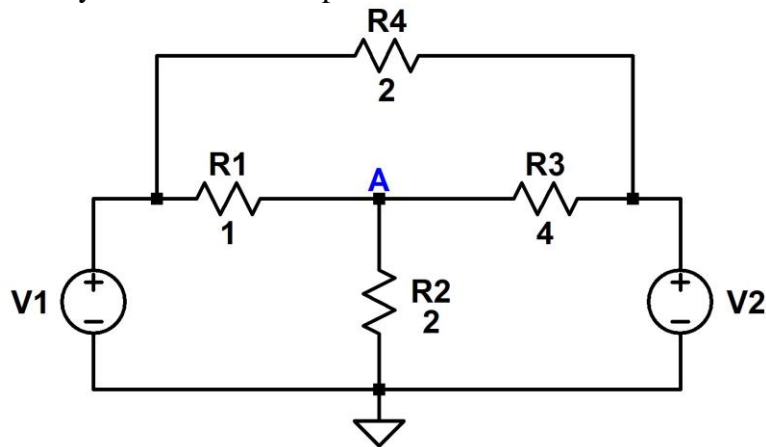

The voltage at V_2 was set to zero and the voltage V_1 was swept from 0 to 5V. Sketch the voltage at node A to plot V_A vs. V_1 (with $V_2 = 0$) in the graph below. Label axes clearly.



Similarly, the voltage at V1 was set to zero and the voltage V2 was swept from 0 to 5V. Sketch the voltage at node A to plot VA vs. V2 (with V1 = 0) in the graph below. Label axes clearly.



Based on the above results for the two source circuit, determine the voltage at node A when V1 = 4 V and V2 = 2 V.

Answer: _____