

Intro to ECSE

Quiz 1

Spring 2024

1.	/18
2.	/16
3.	/12
Total	/46

Name _____

RIN _____

Notes:

SHOW ALL WORK. BEGIN WITH FORMULAS, THEN SUBSTITUTE VALUES AND UNITS. No credit will be given for numbers that appear without justification.

Use the backs of pages if there is not enough room on the front.

For partial credit on some questions, you may want to re-draw circuit diagrams as you simplify the circuits. Work through a problem in terms of variables, then substitute numerical values when you are ready to solve it.

Many problems can be solved using more than one method. Check your answers by using a second method.

At least skim through the entire quiz before you begin and then start with the problems you know best. The proctor will only answer clarification questions where wording is unclear or where there may be errors/typos. No other questions will be responded to.

Problem 1 (18 Points): Combining Resistors, Circuit Reduction, Voltage Dividers

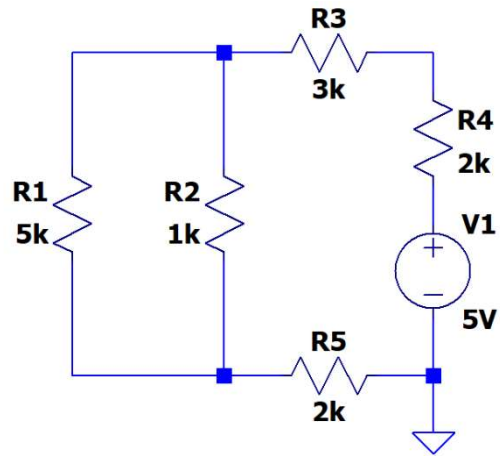

Figure 1

a) (2 pts) In the circuit diagram above, which of the resistors (if any) are in series? Do not combine resistors before answering this question.

b) (2 pts) In the circuit diagram above, which of the resistors (if any) are in parallel? Do not combine resistors before answering this question.

c) (3 pts) Find the voltage across R5. Redraw the circuit that helps you find VR5.

d) (3 pts) Find the current through R1.

e) (4 pts) Reduce the circuit in Figure 1 to the circuit in Figure 2. What is the value of Req?

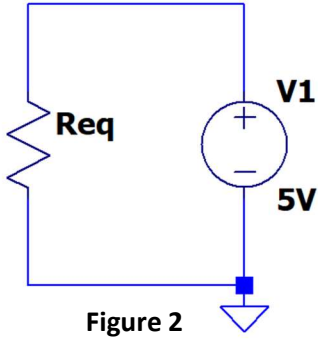

f) (4 pts) You want to design a circuit that takes a 5V input voltage and divides it into two output voltages: $V_{out1} = 1V$ and $V_{out2} = 4V$. Using the circuit schematic below, choose values for R1 and R2 to satisfy the above design requirement. You may use each resistor value only once but may combine resistors in series or in parallel to obtain values for R1 and R2.

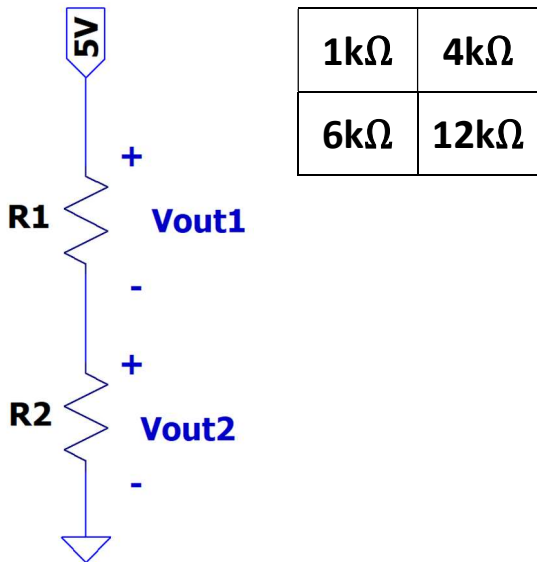

R1: _____

R2: _____

Problem 2 (16 pts): KVL/KCL/Ohm's Law Method of Circuit Analysis

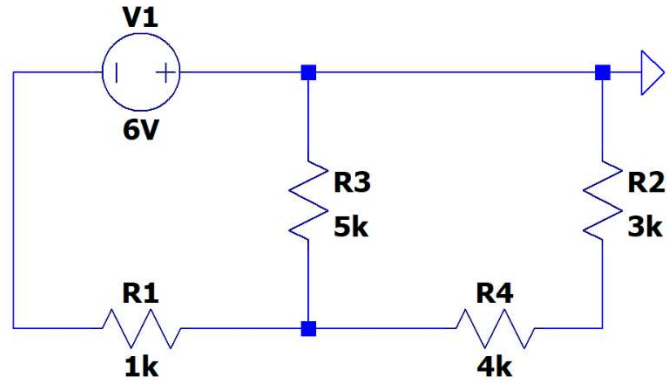

- a) (4 pts) How many nodes are in the circuit above? How many loops are there? Label all nodes and loops on the circuit diagram.
- b) (2 pts) How many unknowns are there in this circuit as it is drawn (i.e. do not combine resistances)?
- c) (2 pts) Draw reference marks on your circuit diagram.

d) (4 pts) Write the linearly independent equations that will solve for all unknowns in the circuit in terms of **current** (i.e., in the final form of your equations, the unknowns must be expressed in terms of current).

e) (4 pts) Write the equations in matrix form, giving your final answer in terms of numerical values for circuit elements. Note: You do not have to solve the matrix equation to obtain a numerical answer for the unknowns, but you may if you'd like to check your answer. If you do choose to solve the matrix equation, that work will not be graded.

Problem 3 (12 pts): Electric Circuit Fundamentals and Proof of Skills

- a) (2 pts) *Circuit Fundamentals*: True or False: When combining resistances in parallel, the resulting equivalent resistance is always greater than each of the individual parallel resistances (circle one):

True

False

- b) (5 pts) *LTSpice*: Shown below is a circuit and the corresponding output from a DC operating point simulation. Give the voltages across resistors R1 through R4 (as shown in the schematic) on the lines provided. Give your answer in volts to the nearest 0.01V.

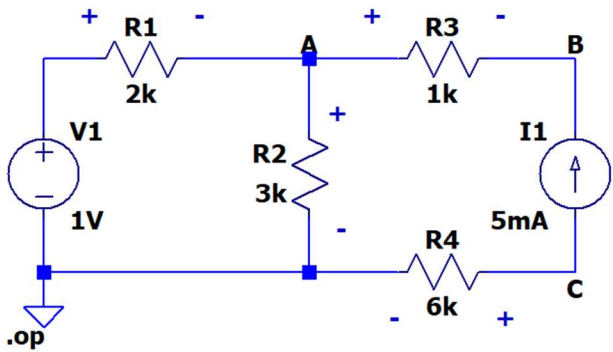

--- Operating Point ---		
V(n001) :	1	voltage
V(a) :	6.6	voltage
V(b) :	11.6	voltage
V(c) :	-30	voltage
I(I1) :	0.005	device_current
I(R4) :	0.005	device_current
I(R3) :	-0.005	device_current
I(R2) :	-0.0022	device_current
I(R1) :	0.0028	device_current
I(V1) :	0.0028	device_current

V_{R1} _____ V

V_{R2} _____ V

V_{R3} _____ V

V_{R4} _____ V

c) (5 pts) *Instrumentation and Experimental Measurement*: Shown below is a circuit schematic and its corresponding breadboard circuit.

In the breadboard circuit below, multiple wires are connected to different points in the circuit. Next to each wire, there is a box for you to write the name of a signal wire from the M2K or AD2 (for example V+, 1+, Gnd, etc.) that you could connect to that point in the circuit. For the questions below, write your answers in the provided boxes. The signal wire layouts and labels for the M2K and AD2 are provided for you. Note: it may be the case that not all wires are used. If you don't plan to use a wire, leave its box blank.

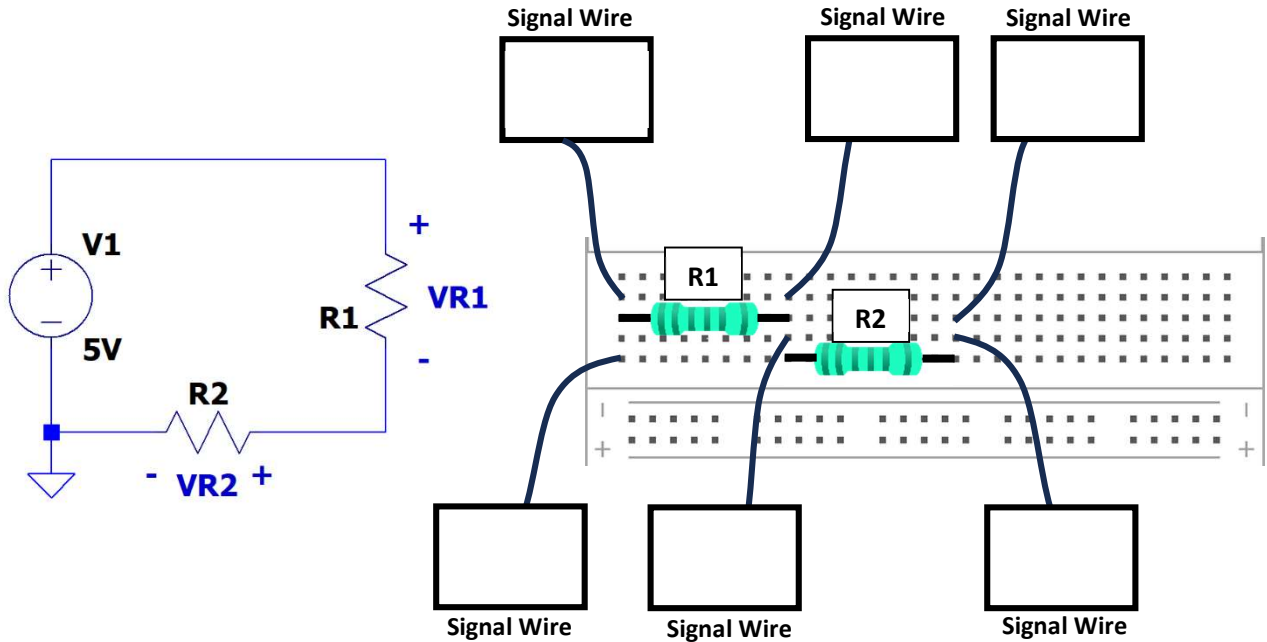

- i) Label which signal wires you would connect to the circuit from the M2K or AD2 **to power your circuit** as shown in the circuit schematic on the left.
- ii) Label which signal wires you would connect to the circuit from the M2K or AD2 **to measure the voltage across R2** as shown in the circuit schematic on the left.

