

Questions about Transfer Functions

These questions should help you with question 3 of quiz 1.

Fall 2004

Question I – Transfer functions of RLC, RL and RC Circuits (52 points)

Circuit A: Answer 1-8 for the RC circuit below

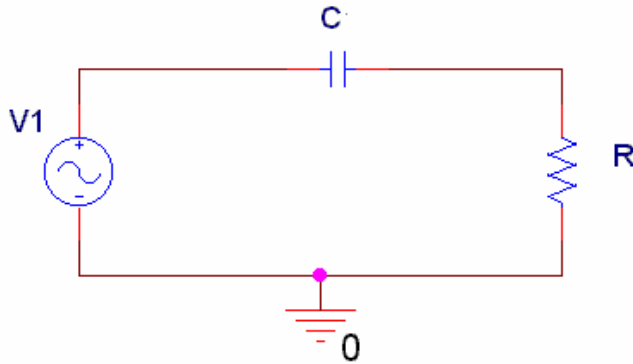

1. Find the transfer function for the above circuit. (2 points)

$$H(j\omega) =$$

2. Find the function to describe the behavior of the circuit at very low frequencies. Also determine the magnitude and phase of this circuit at very low frequencies. (3 points)

$$H_{LO}(j\omega) =$$

$$|H_{LO}| = \qquad \angle H_{LO} =$$

3. Find the function to describe the behavior of the circuit at very high frequencies. Also determine the magnitude and phase of this circuit at very high frequencies. (3 points)

$$H_{HI}(j\omega) =$$

$$|H_{HI}| = \qquad \angle H_{HI} =$$

4. What is the expression for the corner frequency of the circuit? (1 point)

$$\omega_c =$$

5. Find the transfer function which governs the behavior of the circuit at the corner frequency, ω_c . Also find the magnitude and phase of the function at the corner frequency. (3 points)

$$H_C =$$

$$|H_C| = \qquad \angle H_C =$$

6. If $C=0.047\mu\text{F}$ and $R=500$ ohms, find the numerical values for the following. Indicate the units. (8 points)

$$\omega_c =$$

$$f_c =$$

	Magnitude	Phase
Very low frequencies		
Very high frequencies		
Corner frequency		

7. Sketch a plot of the magnitude of the transfer function vs frequency (in Hertz). Clearly indicate the value at very high frequencies, very low frequencies and the corner frequency. Mark the corner frequency on the sketch. (3 points)
8. Sketch a plot of the phase of the transfer function (in degrees or radians). Clearly indicate the value at very high frequencies, very low frequencies and the corner frequency. Mark the corner frequency on the sketch. (3 points)

Circuit B: Answer 9-16 for the RLC circuit below

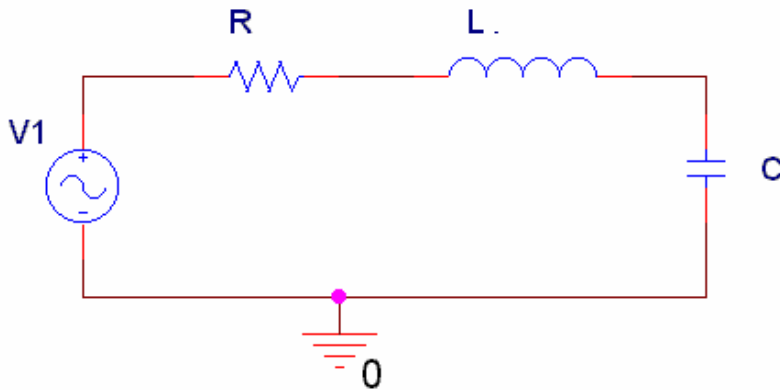

9. Find the transfer function for the above circuit. (2 points)

$$H(j\omega) =$$

10. Find the function to describe the behavior of the circuit at very low frequencies. Also determine the magnitude and phase of this circuit at very low frequencies. (3 points)

$$H_{LO}(j\omega) =$$

$$|H_{LO}| = \quad \angle H_{LO} =$$

11. Find the function to describe the behavior of this circuit at very high frequencies. Also determine the magnitude and phase of this circuit at very high frequencies. (3 points)

$$H_{HI}(j\omega) =$$

$$|H_{HI}| = \quad \angle H_{HI} =$$

12. What is the expression for the resonant frequency of the circuit? (1 point)

$$\omega_0 =$$

13. Find the transfer function which governs the behavior of the circuit at the resonant frequency, ω_0 . Also find the magnitude and phase of the function at the resonant frequency. (3 points)

$$H_0 =$$

$$|H_0| = \quad \angle H_0 =$$

14. If $C=0.063\mu\text{F}$, $L=10\text{mH}$ and $R=800$ ohms, find the numerical values for the following. Indicate the units. (8 points)

$$\omega_0 =$$

$$f_0 =$$

	Magnitude	Phase
Very low frequencies		
Very high frequencies		
Resonant frequency		

15. Sketch a plot of the magnitude of the transfer function vs frequency in Hertz. Clearly indicate the value at very high frequencies, very low frequencies and the resonant frequency. Mark the resonant frequency on the sketch. (3 points)

16. Sketch a plot of the phase of the transfer function (in degrees or radians). Clearly indicate the value at very high frequencies, very low frequencies and the corner frequency. Mark the resonant frequency on the sketch. (3 points)

Fall 2004 Solution

Circuit A: Answer 1-8 for the RC circuit below

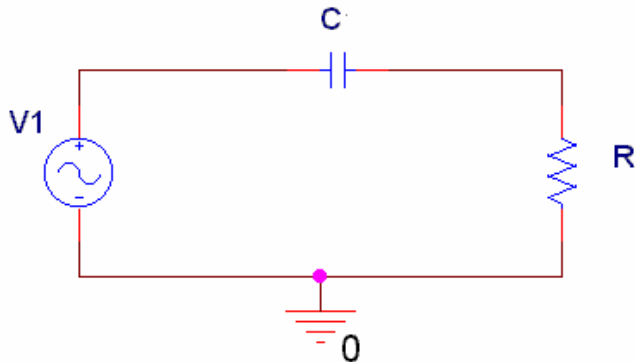

1. Find the transfer function for the above circuit. (2 points)

$$H(j\omega) = [R] / [1/j\omega C + R] = [j\omega RC] / [1 + j\omega RC]$$

4. Find the function to describe the behavior of the circuit at very low frequencies. Also determine the magnitude and phase of this circuit at very low frequencies. (3 points)

$$H_{LO}(j\omega) = [j\omega RC] / [1] = j\omega RC$$

$$|H_{LO}| = 0 \quad \angle H_{LO} = \pi/2$$

5. Find the function to describe the behavior of the circuit at very high frequencies. Also determine the magnitude and phase of this circuit at very high frequencies. (3 points)

$$H_{HI}(j\omega) = [j\omega RC] / [j\omega RC] = 1$$

$$|H_{HI}| = 1 \quad \angle H_{HI} = 0$$

4. What is the expression for the corner frequency of the circuit? (1 point)

$$\omega_c = [1]/[RC]$$

9. Find the transfer function which governs the behavior of the circuit at the corner frequency. Also find the magnitude and phase of the function at the corner frequency. (3 points)

$$H_C = [j(1/RC)RC] / [1 + j(1/RC)RC] = [j] / [1 + j]$$

$$|H_C| = 1 / \sqrt{2} \quad \angle H_C = \pi/2 - \pi/4 = \pi/4$$

10. If $C=0.047\mu\text{F}$ and $R=500$ ohms, find the numerical values for the following. Indicate the units. (8 points)

$$\omega_c = 1/[(0.047\mu)(500)] = 42553 \text{ rad/s} \quad f_c=42553/2\pi = 6773 \text{ Hz}$$

	Magnitude	Phase
Very low frequencies	0	$\pi/2$
Very high frequencies	1	0
Corner frequency	$1/\sqrt{2}$	$\pi/4$

11. Sketch a plot of the magnitude of the transfer function vs frequency (in Hertz). Clearly indicate the value at very high frequencies, very low frequencies and the corner frequency. Mark the corner frequency on the sketch. (3 points)

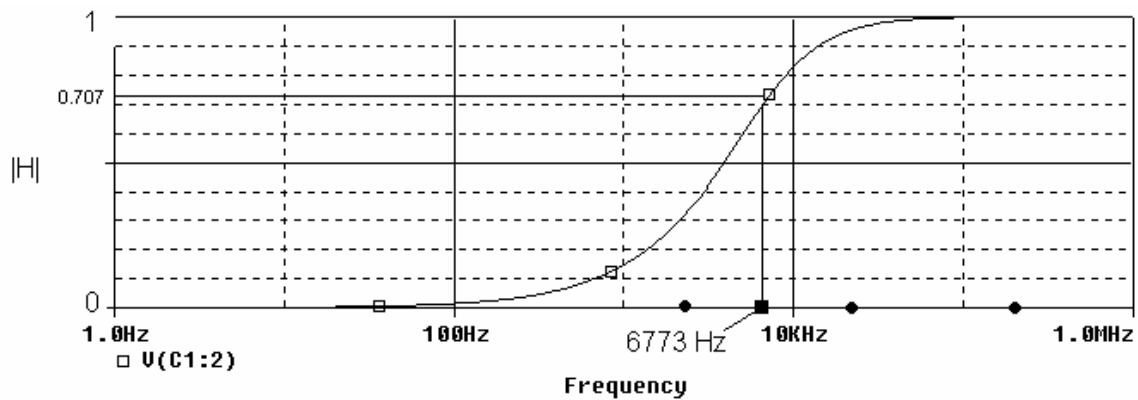

12. Sketch a plot of the phase of the transfer function (in degrees or radians). Clearly indicate the value at very high frequencies, very low frequencies and the corner frequency. Mark the corner frequency on the sketch. (3 points)

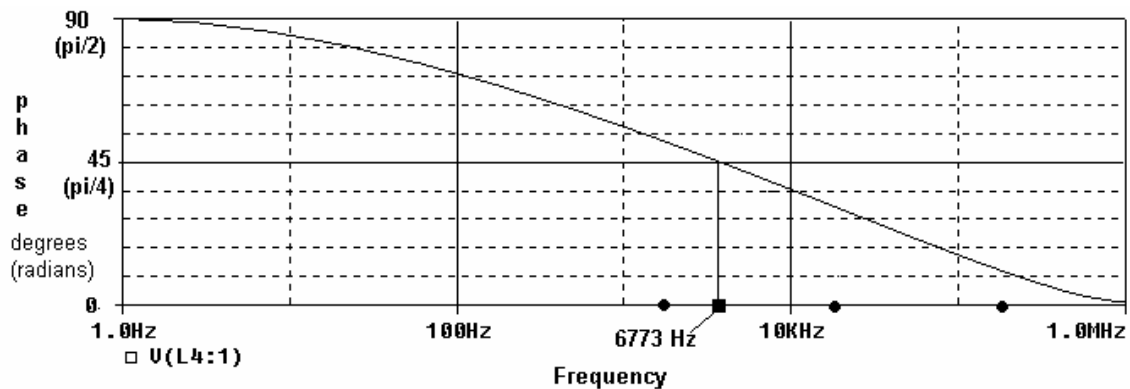

Circuit B: Answer 9-16 for the RLC circuit below

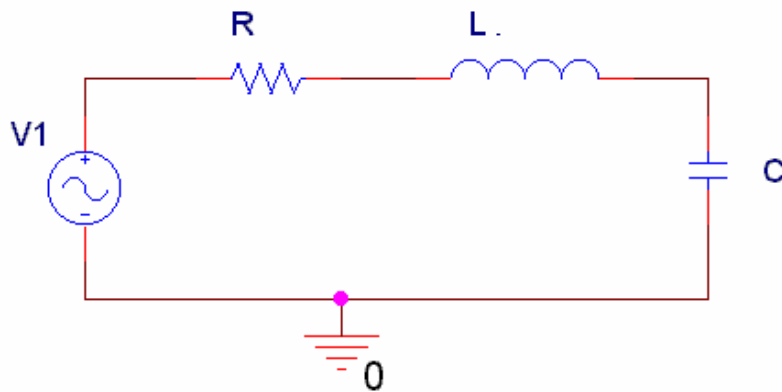

9. Find the transfer function for the above circuit. (2 points)

$$H(j\omega) = [1/j\omega C] / [R + j\omega L + 1/j\omega C] = [1] / [j\omega RC - \omega^2 LC + 1]$$

12. Find the function to describe the behavior of the circuit at very low frequencies. Also determine the magnitude and phase of this circuit at very low frequencies. (3 points)

$$H_{LO}(j\omega) = [1] / [1] = 1$$

$$|H_{LO}| = 1 \quad \angle H_{LO} = 0$$

13. Find the function to describe the behavior of this circuit at very high frequencies. Also determine the magnitude and phase of this circuit at very high frequencies. (3 points)

$$H_{HI}(j\omega) = [1] / [-\omega^2 LC]$$

$$|H_{HI}| = 0 \quad \angle H_{HI} = -\pi$$

12. What is the expression for the resonant frequency of the circuit? (1 point)

$$\omega_0 = 1/(\sqrt{LC})$$

13. Find the transfer function which governs the behavior of the circuit at the resonant frequency. Also find the magnitude and phase of the function at the resonant frequency. (3 points)

$$H_0 = [1] / [j (1/\sqrt{LC})RC - (1/LC)(LC) + 1] = [-j\sqrt{LC}] / [RC]$$

$$|H_0| = [\sqrt{LC}] / [RC] \quad \angle H_0 = -\pi/2$$

17. If $C=0.063\mu\text{F}$, $L=10\text{mH}$ and $R=800$ ohms, find the numerical values for the following. Indicate the units. (8 points)

$$\omega_0 = [1]/[\sqrt{(0.063\mu)(10\text{m})}] = 39841 \text{ rad/s} \quad f_0 = 39841/2\pi = 6341 \text{ Hz}$$

$$|H_0| = [\sqrt{LC}] / [RC] = [\sqrt{(0.063\mu)(10\text{m})}] / [(800)(0.063\mu)] = 0.5$$

	Magnitude	Phase
Very low frequencies	1	0
Very high frequencies	0	$-\pi$
Resonant frequency	0.5	$-\pi/2$

18. Sketch a plot of the magnitude of the transfer function vs frequency in Hertz. Clearly indicate the value at very high frequencies, very low frequencies and the resonant frequency. Mark the resonant frequency on the sketch. (3 points)

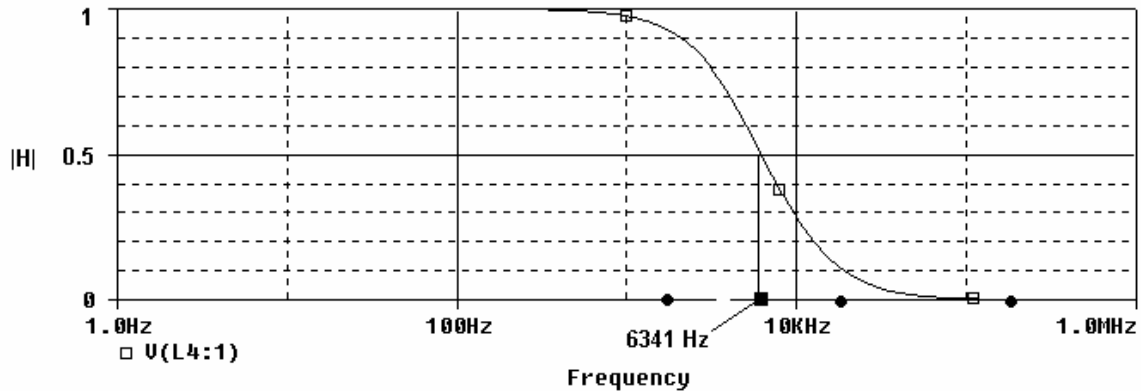

19. Sketch a plot of the phase of the transfer function (in degrees or radians). Clearly indicate the value at very high frequencies, very low frequencies and the corner frequency. Mark the resonant frequency on the sketch. (3 points)

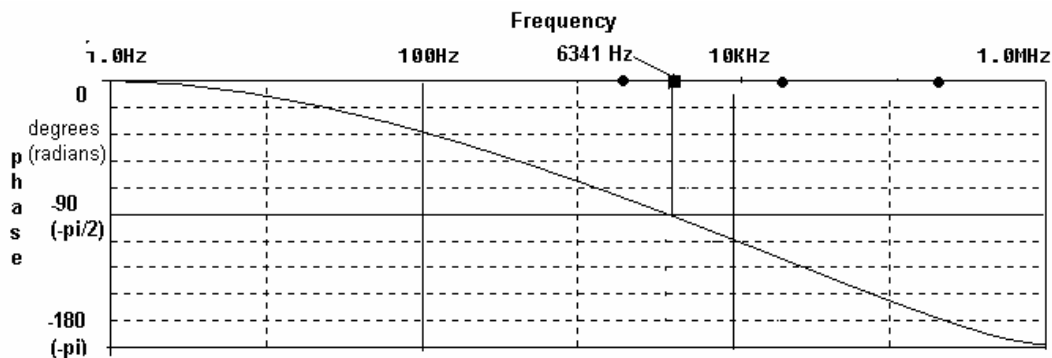

Fall 2004

Question II – Filters (16 points)

Consider the following three input signals:

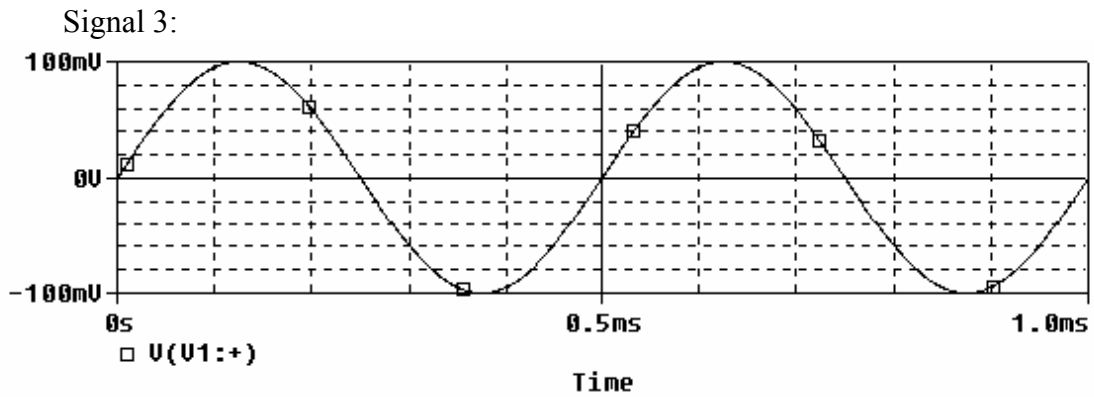
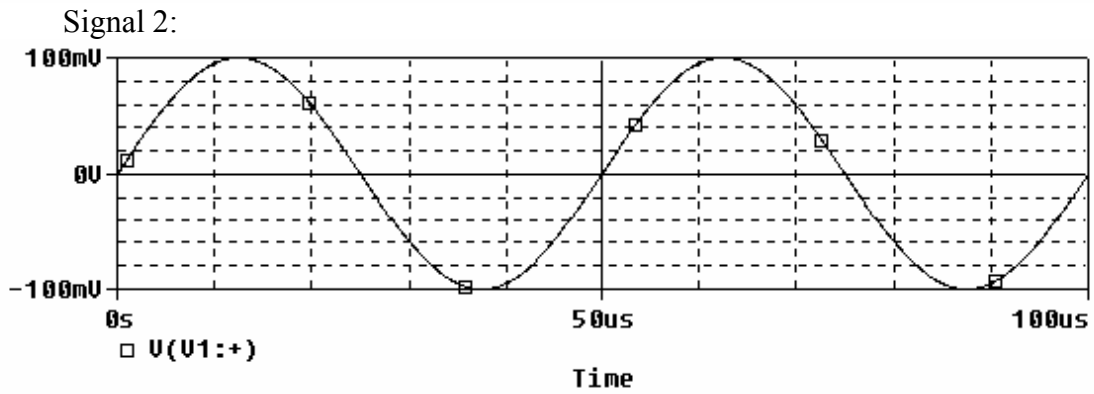
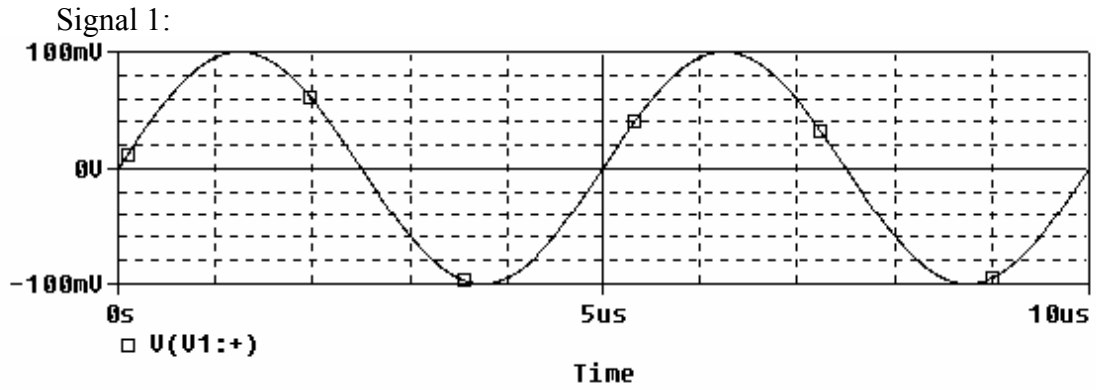

1. What is the frequency of each of the signals above (in Hertz)? (6 points)

Signal 1:

Signal 2:

Signal 3:

2. What type of filter is circuit A from question I ? (2 point)

3. What type of filter is circuit B from question I ? (2 point)

4. Fill out the following chart. Enter “lower” if the amplitude of the output of the given circuit will be substantially lower than the input amplitude. Enter “higher” if the amplitude of the output of the given circuit will be substantially higher than the input amplitude. Enter “same” if the amplitude of the output of the given circuit will be about the same as the input amplitude. Note that the circuits are the ones you analyzed in question I (with the component values we gave you) and the signals are those pictured on the previous page. You can assume the filter transitions are close to ideal. (6 points)

	Signal 1	Signal 2	Signal 3
Circuit A			
Circuit B			

Fall 2004 solution

Question II – Filters (16 points)

Consider the following three input signals:

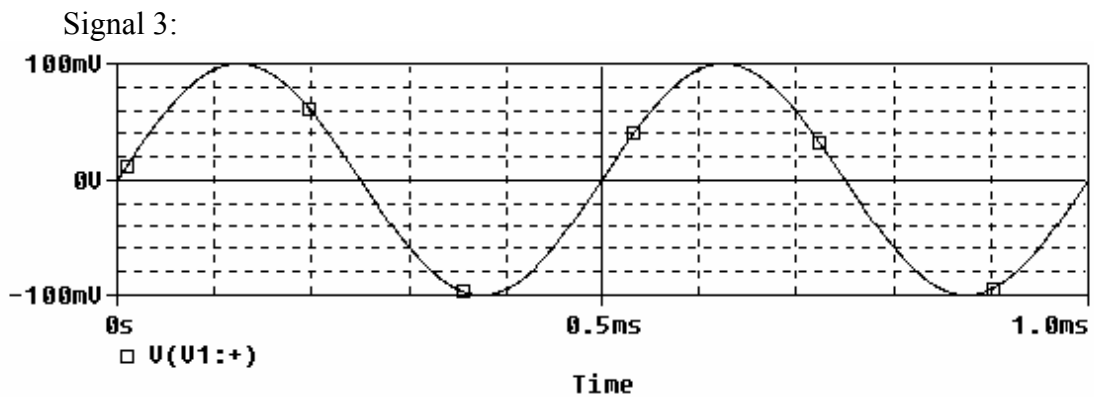
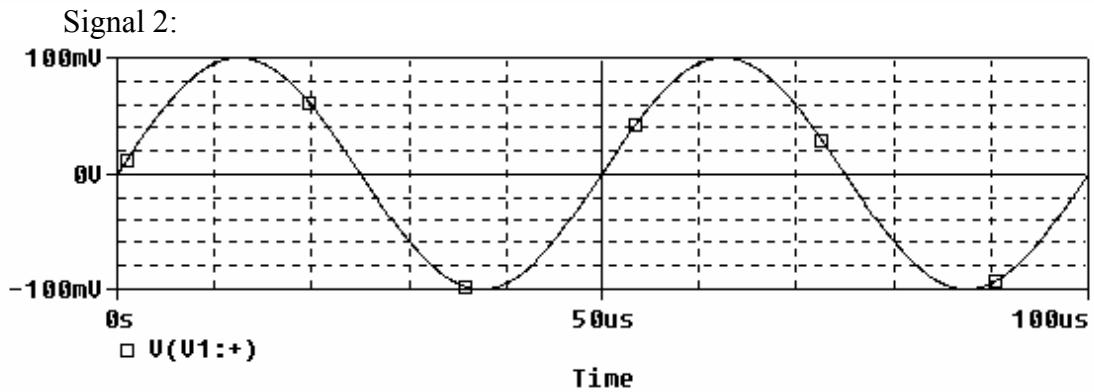
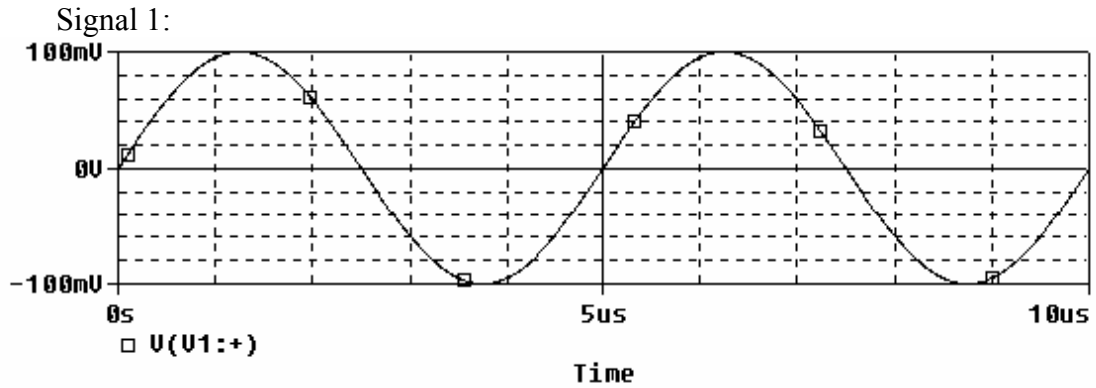

5. What is the frequency of each of the signals above (in Hertz)? (6 points)

Signal 1: $T = 5\mu\text{s}$ $f = 200,000\text{ Hz}$

Signal 2: $T = 50\mu\text{s}$ $f = 20,000\text{ Hz}$

Signal 3: $T = 0.5\text{ms}$ $f = 2000\text{ Hz}$

6. What type of filter is circuit A from question I ? (2 point)

High pass filter

7. What type of filter is circuit B from question I ? (2 point)

Low pass filter

8. Fill out the following chart. Enter “lower” if the amplitude of the output of the given circuit will be substantially lower than the input amplitude. Enter “higher” if the amplitude of the output of the given circuit will be substantially higher than the input amplitude. Enter “same” if the amplitude of the output of the given circuit will be about the same as the input amplitude. Note that the circuits are the ones you analyzed in question I (with the component values we gave you) and the signals are those pictured on the previous page. You can assume the filter transitions are close to ideal. (6 points)

	200K	20K	2K
	Signal 1	Signal 2	Signal 3
Circuit A	same	same	lower
Circuit B	lower	lower	same

(see dots marked on plots in answers to question I)

Spring 2004

Question 1 – Transfer Functions (32 points)

Consider a variety of filter configurations that can be analyzed with PSpice. All the resistors (except one) shown are 1k, all the inductors are 1mH and all the capacitors are 0.1 μ F. In general the components can assume any realistic value. Thus, in most of this problem, we will only assume that they have some unknown value. *For each of these circuits, assume that the input and output voltages are measured at the two locations where we have added a voltage marker.*

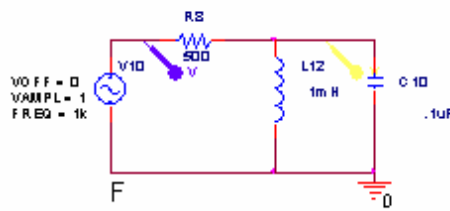
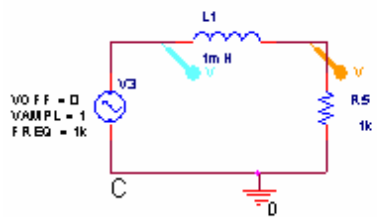
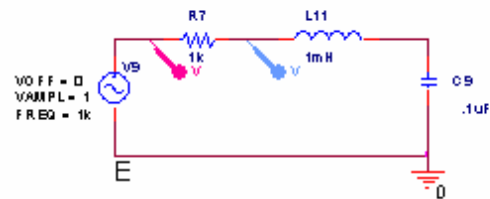
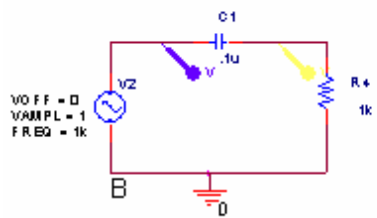
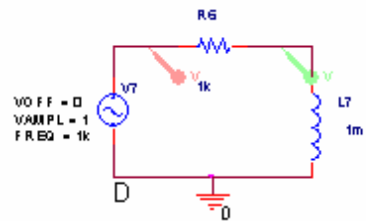
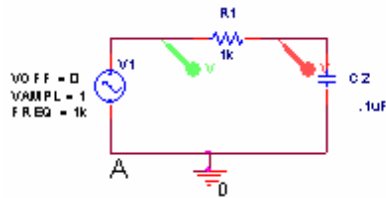

a) First, identify which type of filter these are: (6 points)

Which is a low pass filter (list all):

Which is a high pass filter (list all):

Which is a band pass filter (list all):

Which is a band reject filter (list all):

- b) The complex transfer functions for all of these filters are given below. Identify which circuit goes with each transfer function. (6 points)

$$\frac{j\omega L}{R + j\omega L}$$

$$\frac{1/j\omega C + j\omega L}{R + j\omega L + 1/j\omega C}$$

$$\frac{R}{R + 1/j\omega C}$$

$$\frac{R}{R + j\omega L}$$

$$\frac{\frac{j\omega L}{j\omega C}}{j\omega L + \frac{1}{j\omega C}}$$

$$R + \frac{\frac{j\omega L}{j\omega C}}{j\omega L + \frac{1}{j\omega C}}$$

$$\frac{1/j\omega C}{R + 1/j\omega C}$$

- c) The voltage and phase vs frequency for each of these filters is shown on the following two pages. Identify which plot goes with each transfer function. Show your work below for partial credit: (12 points)

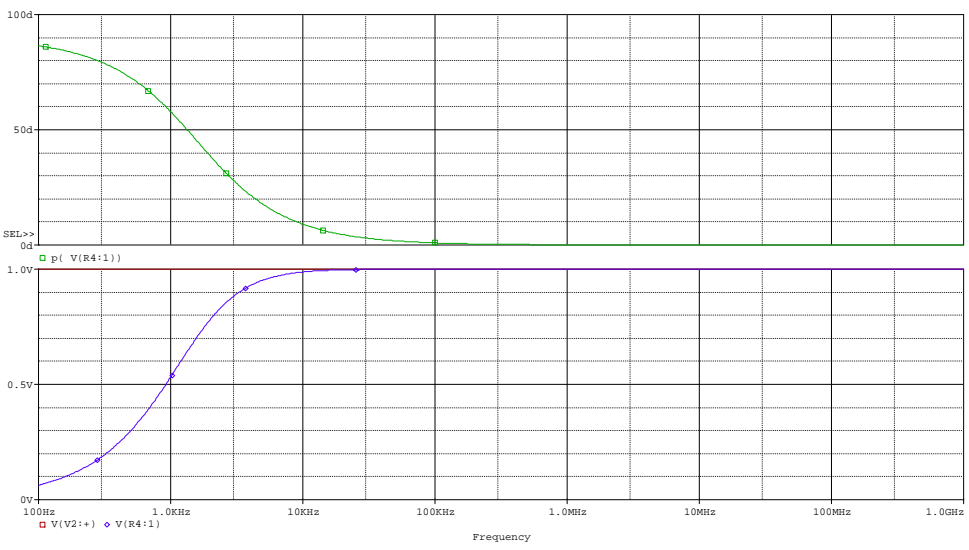
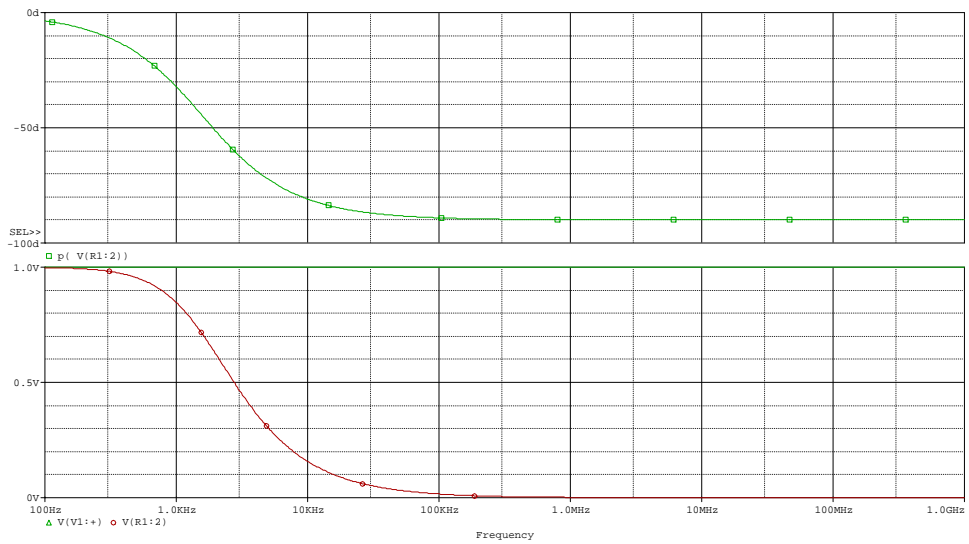

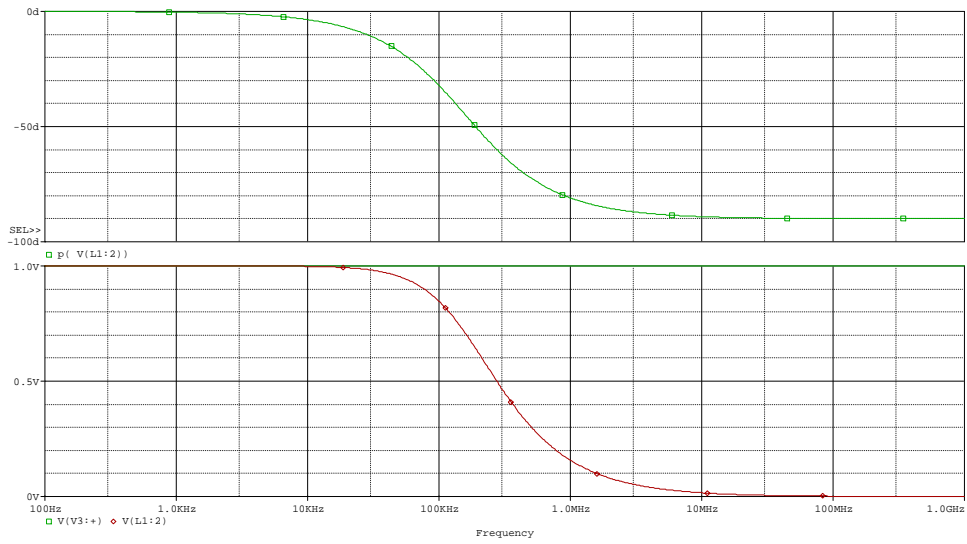

- d) Find the transfer function for the following circuit. (Hint- it is a combination of two of the circuits we have seen above.) (4 points)

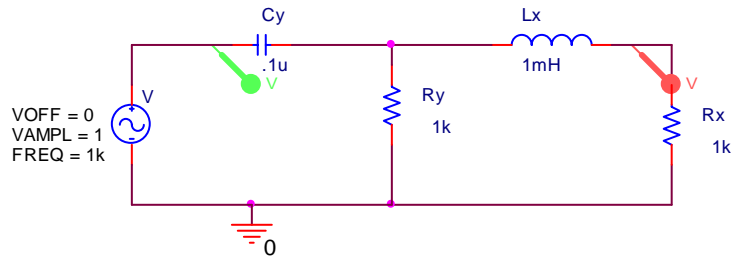

- e) Simplify this transfer function at very low frequencies and very high frequencies and show that your results are consistent with the voltage magnitude and phase plot below. What kind of a filter is this combined circuit? (4 points)

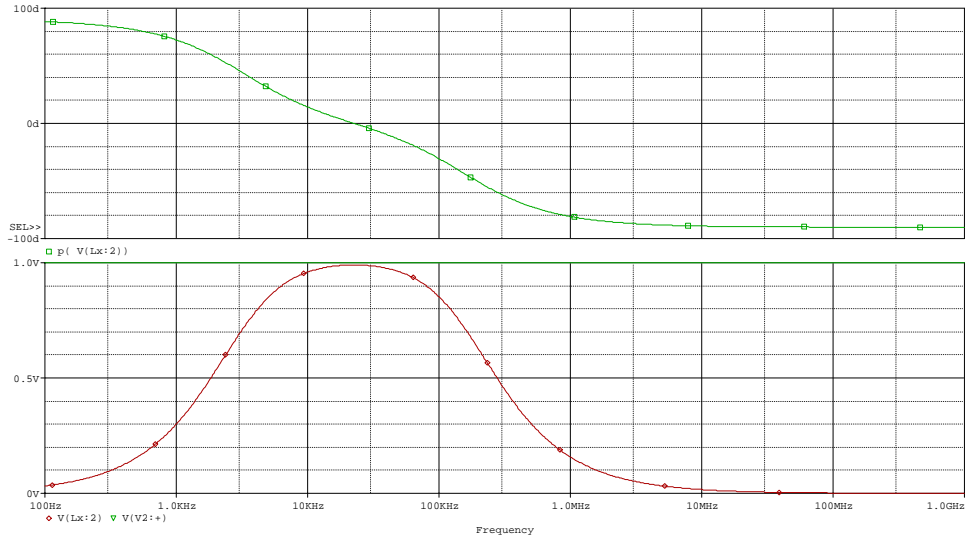

- f) Extra Credit – Which of the original eight filters is also a combination of two other filters? Explain your answer.

Spring 2004 solution

Question 1 – Transfer Functions (32 points)

Consider a variety of filter configurations that can be analyzed with PSpice. All the resistors (except one) shown are 1k, all the inductors are 1mH and all the capacitors are 0.1 μ F. In general the components can assume any realistic value. Thus, in most of this problem, we will only assume that they have some unknown value. *For each of these circuits, assume that the input and output voltages are measured at the two locations where we have added a voltage marker.*

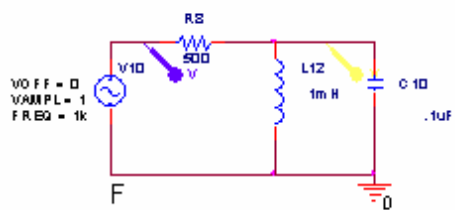
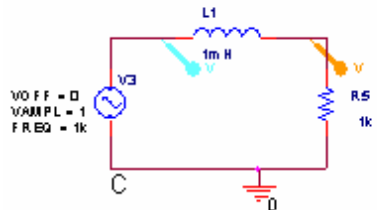
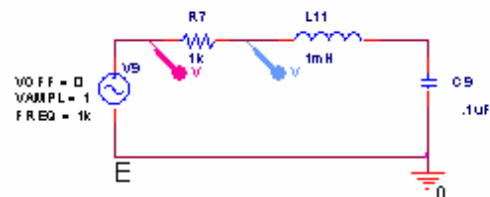
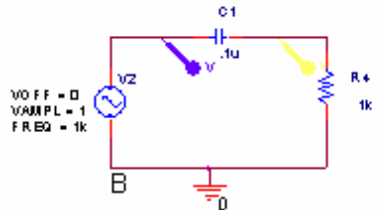
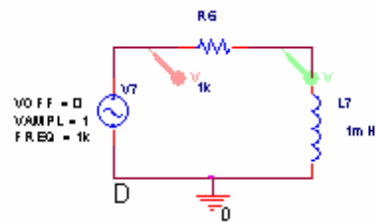
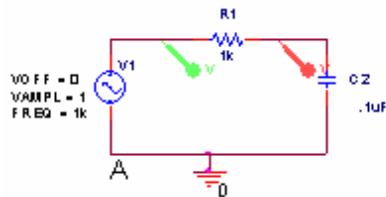

g) First, identify which type of filter these are: (6 points)

Which is a low pass filter (list all): **A, C**

Which is a high pass filter (list all): **B, D**

Which is a band pass filter (list all): **F**

Which is a band reject filter (list all): **E**

- h) The complex transfer functions for all of these filters are given below. Identify which circuit goes with each transfer function. (6 points)

$$\frac{j\omega L}{R + j\omega L} \quad \mathbf{D} \qquad \frac{1/j\omega C + j\omega L}{R + j\omega L + 1/j\omega C} \quad \mathbf{E} \qquad \frac{R}{R + 1/j\omega C} \quad \mathbf{B}$$

$$\frac{R}{R + j\omega L} \quad \mathbf{C} \qquad \frac{\frac{j\omega L}{j\omega C}}{j\omega L + 1/j\omega C} \quad \mathbf{F} \qquad \frac{1/j\omega C}{R + 1/j\omega C} \quad \mathbf{A}$$

$$R + \frac{j\omega L}{j\omega C} \quad \mathbf{F}$$

- i) The voltage and phase vs frequency for each of these filters is shown on the following two pages. Identify which plot goes with each transfer function. Show your work below for partial credit: (12 points)

The easiest way to distinguish between the plots is as follows:

F is the only band pass filter

E is the only band reject filter

A and C are both low pass filters. Find the corner frequency of each to determine which one is which (see below).

B and D are both high pass filters. Find the corner frequency of each to determine which one is which (see below).

Here is the complete analysis of each circuit. Note how each corresponds to the plots.

A:

$$\frac{1/j\omega C}{R + 1/j\omega C} = \frac{1}{j\omega RC + 1} \quad H_{LO} = 1 \quad |H_{LO}| = 1 \quad \angle H_{LO} = 0 \quad H_{HI} = \frac{1}{j\omega RC} \quad |H_{HI}| = 0 \quad \angle H_{HI} = -\frac{\pi}{2}$$

$$\omega_c = \frac{1}{RC} = \frac{1}{(1K)(.1\mu F)} = 10000 \quad f_c = \frac{\omega_c}{2\pi} \approx 1600Hz \quad LPF$$

B:

$$\frac{R}{R + \frac{1}{j\omega C}} = \frac{j\omega RC}{j\omega RC + 1} \quad H_{LO} = j\omega RC \quad |H_{LO}| = 0 \quad \angle H_{LO} = \frac{\pi}{2} \quad H_{HI} = \frac{j\omega RC}{j\omega RC} = 1 \quad |H_{HI}| = 1 \quad \angle H_{HI} = 0$$

$$\omega_c = \frac{1}{RC} = \frac{1}{(1K)(.1\mu F)} = 10000 \quad f_c = \frac{\omega_c}{2\pi} \approx 1600Hz \quad HPF$$

C:

$$\frac{R}{R + j\omega L} \quad H_{LO} = \frac{R}{R} = 1 \quad |H_{LO}| = 1 \quad \angle H_{LO} = 0 \quad H_{HI} = \frac{R}{j\omega L} \quad |H_{HI}| = 0 \quad \angle H_{HI} = -\frac{\pi}{2}$$

$$\omega_c = \frac{R}{L} = \frac{1K}{(1mH)} = 1000000 \quad f_c = \frac{\omega_c}{2\pi} \approx 160000Hz \quad LPF$$

D: $\frac{j\omega L}{R + j\omega L} \quad H_{LO} = \frac{j\omega L}{R} \quad |H_{LO}| = 0 \quad \angle H_{LO} = \frac{\pi}{2} \quad H_{HI} = \frac{j\omega L}{j\omega L} = 1 \quad |H_{HI}| = 1 \quad \angle H_{HI} = 0$

$$\omega_c = \frac{R}{L} = \frac{1K}{(1mH)} = 1000000 \quad f_c = \frac{\omega_c}{2\pi} \approx 160000Hz \quad HPF$$

$$\frac{\frac{1}{j\omega C} + j\omega L}{R + j\omega L + \frac{1}{j\omega C}} = \frac{1 - \omega^2 LC}{j\omega RC + 1 - \omega^2 LC} \quad H_{LO} = \frac{1}{1} \quad |H_{LO}| = 1 \quad \angle H_{LO} = 0$$

E: $H_{HI} = \frac{-\omega^2 LC}{-\omega^2 LC} = 1 \quad |H_{HI}| = 1 \quad \angle H_{HI} = 0$

$$\omega_0 = \frac{1}{\sqrt{LC}} = \frac{1}{\sqrt{(1m)(0.1\mu)}} = 100000 \quad f_0 = \frac{\omega_0}{2\pi} \approx 16000Hz \quad BRF$$

$$\begin{aligned}
& \frac{\frac{j\omega L}{j\omega C}}{j\omega L + 1/j\omega C} = \frac{\frac{j\omega L}{-\omega^2 LC + 1}}{R + \frac{j\omega L}{-\omega^2 LC + 1}} = \frac{j\omega L}{R(1 - \omega^2 LC) + j\omega L} \\
\text{F: } & \frac{j\omega L}{j\omega L + 1/j\omega C} \\
H_{Lo} &= \frac{j\omega L}{R} \quad |H_{Lo}| = 0 \quad \angle H_{Lo} = \frac{\pi}{2} \\
H_{Hi} &= \frac{j\omega L}{-\omega^2 RLC} = \frac{-j}{\omega RC} \quad |H_{Hi}| = 0 \quad \angle H_{Hi} = -\frac{\pi}{2} \\
\omega_0 &= \frac{1}{\sqrt{LC}} = \frac{1}{\sqrt{(1m)(0.1\mu)}} = 100000 \quad f_0 = \frac{\omega_0}{2\pi} \approx 16000\text{Hz} \quad \text{BPF}
\end{aligned}$$

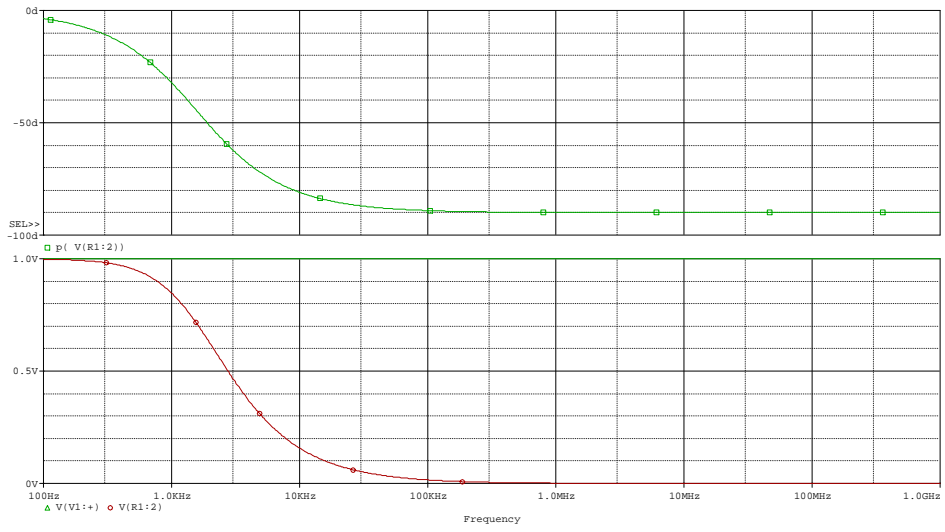

A

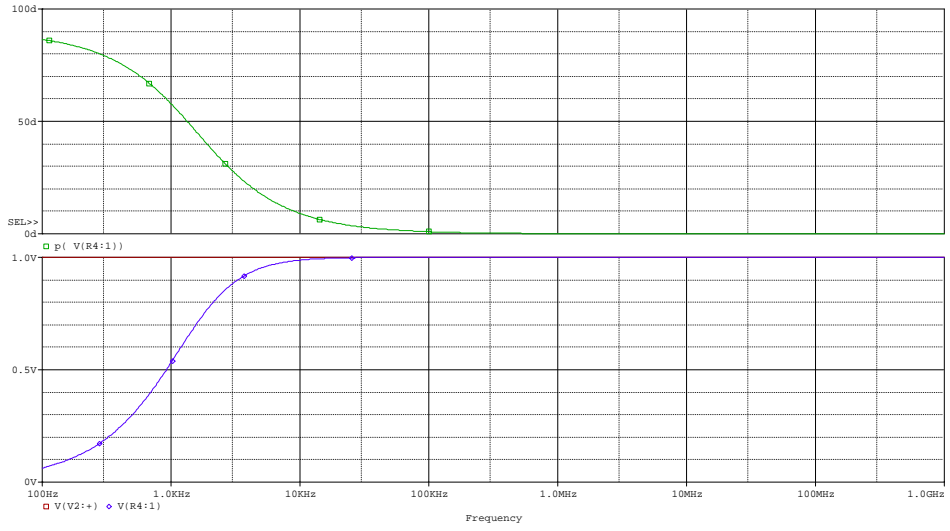

B

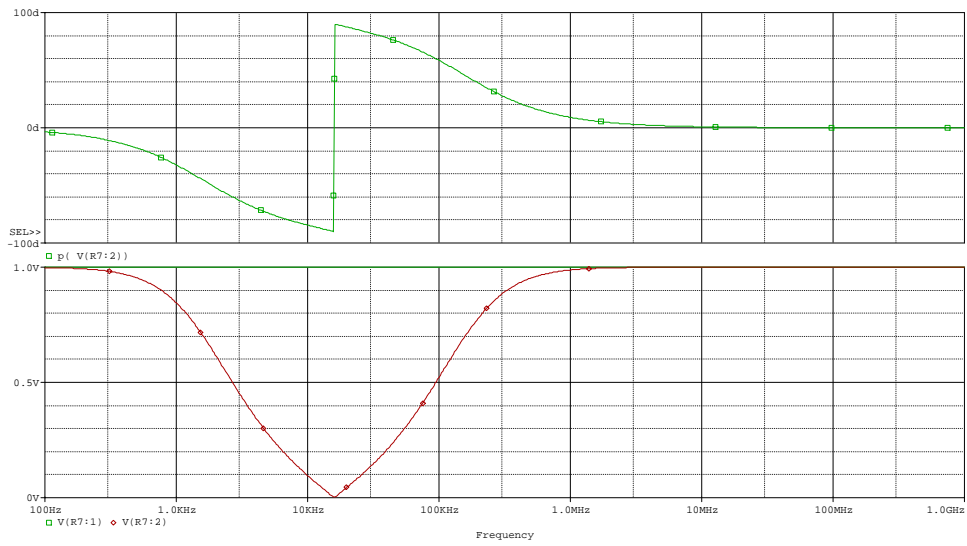

E

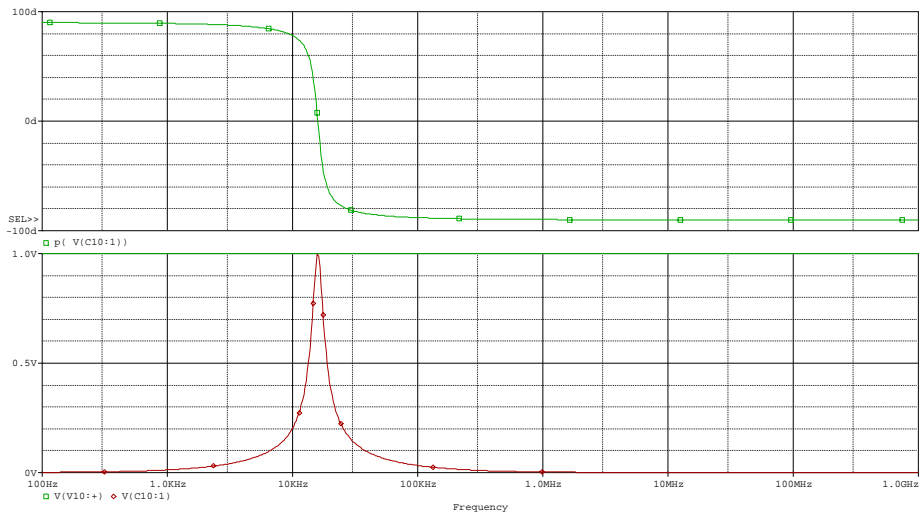

F

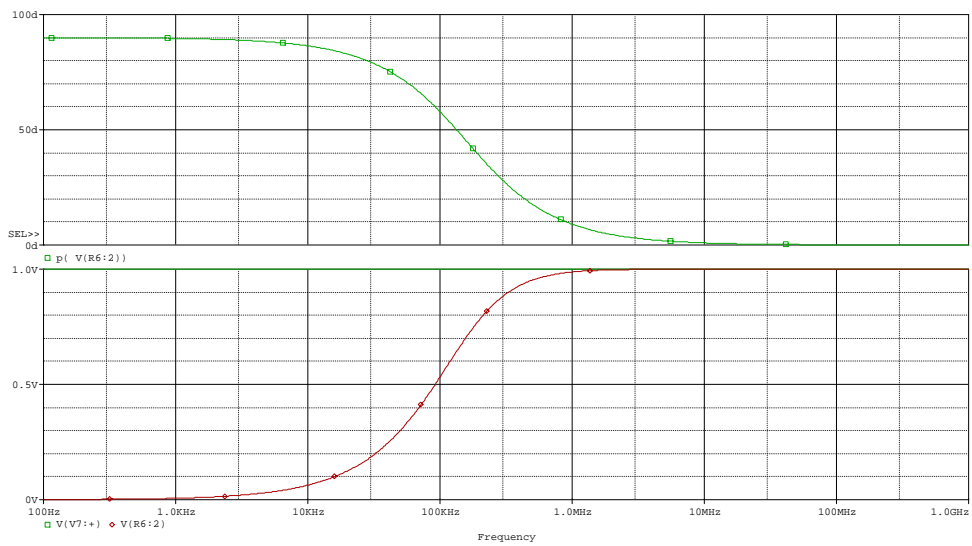

D

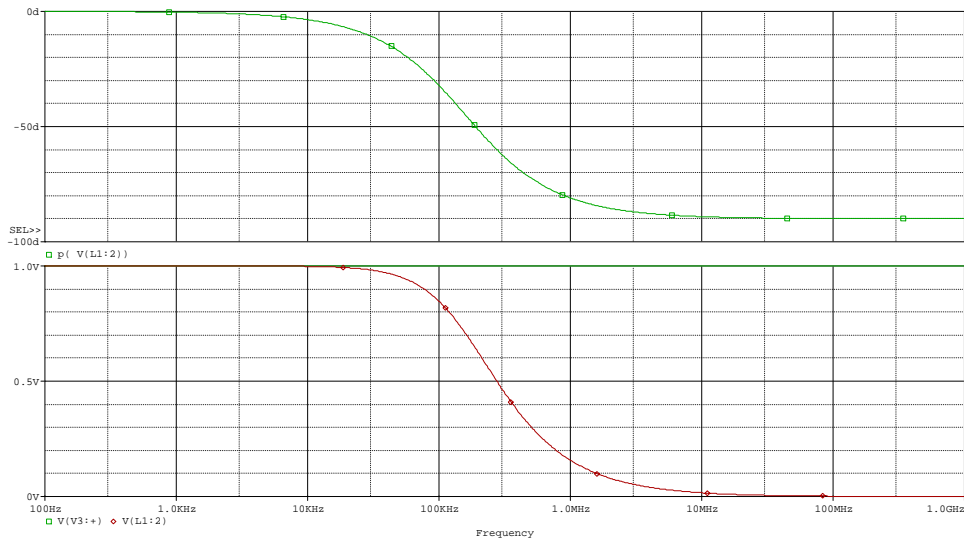

C

- j) Find the transfer function for the following circuit. Assume there is a buffer at point A which forces the two transfer functions to be separate. (Hint- it is a combination of two of the circuits we have seen above.) (4 points)

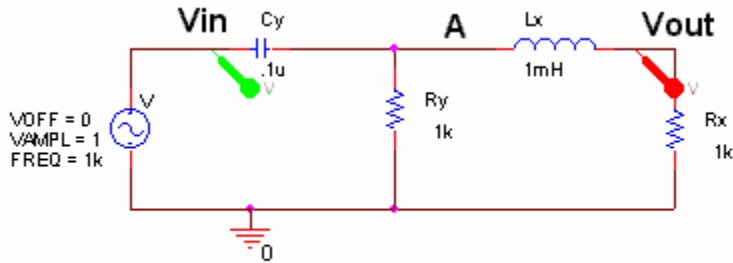

Assuming the presence of the buffer, we can assume that the output of one part of the circuit (y) is the input to the other (x). Hence:

$$\frac{V_A}{V_{in}} = H_y \quad \frac{V_{out}}{V_A} = H_x \quad \frac{V_{out}}{V_{in}} = H_x H_y$$

$$H_y = \frac{R_y}{1/j\omega C_y + R_y} = \frac{j\omega R_y C_y}{1 + j\omega R_y C_y} \quad H_x = \frac{R_x}{j\omega L_x + R_x}$$

$$H_y H_x = \frac{j\omega R_x R_y C_y}{(1 + j\omega R_y C_y)(j\omega L_x + R_x)} = \frac{j\omega R_x R_y C_y}{j\omega L_x + R_x - \omega^2 R_y L_x C_y + j\omega R_y^2 C_y}$$

- k) Simplify this transfer function at very low frequencies and very high frequencies and show that your results are consistent with the voltage magnitude and phase plot below. What kind of a filter is this combined circuit? (4 points)

$$H_y H_x = \frac{j\omega R_x R_y C_y}{j\omega L_x + R_y - \omega^2 R_y L_x C_y + j\omega R_y^2 C_y}$$

$$H_{LO} = \frac{j\omega R_x R_y C_y}{R_y} = j\omega R_x C_y \quad |H_{LO}| = 0 \quad \angle H_{LO} = \frac{\pi}{2} \quad H_{HI} = \frac{j\omega R_x R_y C_y}{-\omega^2 R_y L_x C_y} = \frac{-jR_x}{\omega L_x} \quad |H_{HI}| = 0 \quad \angle H_{HI} = -\frac{\pi}{2}$$

The magnitude is zero at both high and low frequencies, as seen in the plot. The phase is 90 degrees ($\pi/2$) at low frequencies and -90 degrees ($-\pi/2$) at high frequencies.

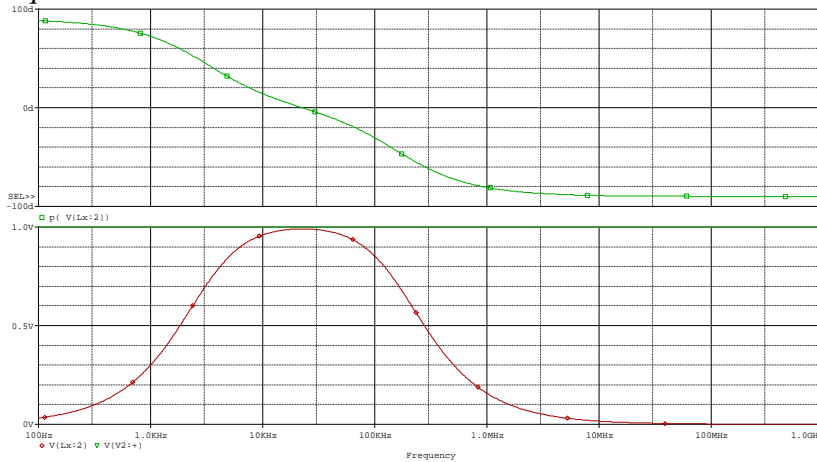

- 1) Extra Credit – Which of the original six filters is also a combination of two other filters? Explain your answer.

The band reject filter, E, is a combination of two other filters. A high pass filter with a corner frequency of 160000 Hertz and a low pass filter with a corner frequency of 1.600 Hertz. This makes it a combination of A and D. You can see this by looking at the plots for both phase and magnitude. When the magnitude of each goes to zero, the other dominates.

Mathematically, this can be shown, but it is not that obvious and you should read the links below if you want to understand it fully....This was not required for the extra point.

$$H_E = \frac{1 - \omega^2 LC}{j\omega RC + 1 - \omega^2 LC} \quad \text{There is a zero at the resonant frequency. To examine the}$$

function below resonance, we throw out the terms that dominate at the highest frequencies. This would be $-\omega^2 LC$. This means that at frequencies below resonance, the function simplifies to

$$H_{E-LO} = \frac{1}{j\omega RC + 1}. \quad \text{This is } H_A, \text{ the filter that determines low frequency behavior. At}$$

frequencies above the resonant frequency, we simplify the function by throwing out the terms that dominate at low frequency. Therefore the function becomes

$H_E = \frac{-\omega^2 LC}{j\omega RC - \omega^2 LC} = \frac{-\omega L}{jR - \omega L} = \frac{-j\omega L}{-R - j\omega L} = \frac{j\omega L}{R + j\omega L}$. This is H_D , the filter that determines high frequency behavior.

The band pass filter, F , is also a combination of two filters. A high pass filter with a corner frequency of around 160000 Hertz and a low pass filter with about the same corner frequency. These are not any of the filters we have here, however, the question is vague about whether you need to combine two filters that are pictured, or just two filters.

For more details on why this is true, see the Gingrich notes:

<http://www.phys.ualberta.ca/%7Egingrich/phys395/notes/node48.html#SECTION00450000000000000000>

and

<http://www.phys.ualberta.ca/%7Egingrich/phys395/notes/node50.html#SECTION00461000000000000000>

Filter design is not always an exact science. Notice how he uses limits to decide the behavior of his circuit elements instead of the exact transfer functions.

Fall 2003

Question 1 -- RLC, RL and RC Circuits (30 points)

Shown below are 5 circuits. Assume the input voltage (V_{in}) is applied across the left-most terminals and the output voltage (V_{out}) is measured across the rightmost terminals.

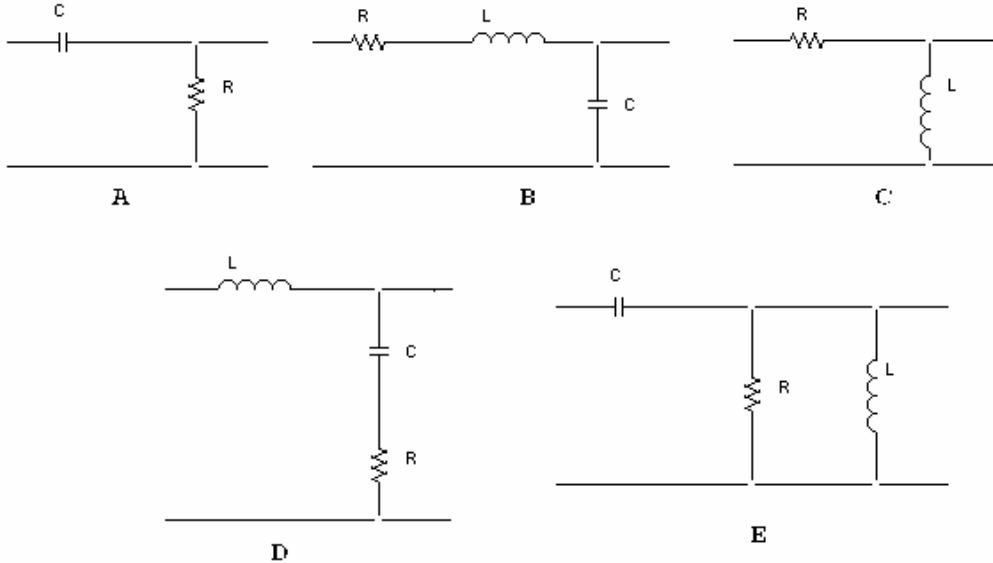

Given below are several possible expressions for generic transfer functions for such circuits. Indicate which circuit goes with which function. (1 point each)

$\frac{j\omega L}{R + j\omega L + \frac{1}{j\omega C}}$	$\frac{R}{R + \frac{1}{j\omega C}}$	$\frac{R + \frac{1}{j\omega C}}{R + j\omega L + \frac{1}{j\omega C}}$	$\frac{j\omega C + \frac{1}{j\omega L}}{R + j\omega C + \frac{1}{j\omega L}}$
$\frac{\frac{1}{j\omega C}}{R + j\omega L + \frac{1}{j\omega C}}$	$\frac{R}{R + j\omega L}$	$\frac{R + j\omega L}{R + j\omega L + \frac{1}{j\omega C}}$	$\frac{R}{j\omega RC + 1}$
$\frac{R}{R + j\omega L + \frac{1}{j\omega C}}$	$\frac{j\omega L}{R + j\omega L}$	$j\omega L + \frac{1}{j\omega C}$	$\frac{1}{j\omega C} + \frac{j\omega LR}{R + j\omega L}$

Find the approximate resonant frequency ω_0 for the RLC circuits and the corner frequency ω_c for the other circuits. That is, write the general expression for each frequency. (1 point each)

A.

B.

C.

D.

E.

Determine the complex transfer function for two of the five circuits (A and B) at the resonant frequency or corner frequency. Be sure your answer is given in terms of R, L, and/or C and does not contain ω . This may seem like an obvious comment, but we want to make sure you have the simplest possible expression. Identify the magnitude and the phase of the transfer function at this frequency.

A. (4 points) $V_{\text{out}}/V_{\text{in}} = H_c =$

$$|H_c| =$$

$$\angle H_c =$$

B. (4 points) $V_{\text{out}}/V_{\text{in}} = H_0 =$

$$|H_0| =$$

$$\angle H_0 =$$

Determine the transfer function, magnitude of the transfer function, and phase of the transfer function at low frequencies for C and D. These should be simplified and expressed these in terms of ω where appropriate.

C. (4 points) $V_{\text{out}}/V_{\text{in}} = H_{\text{lo}}(j\omega) =$

$$|H_{\text{lo}}| =$$

$$\angle H_{\text{lo}} =$$

D. (4 points) $V_{\text{out}}/V_{\text{in}} = H_{\text{lo}}(j\omega) =$

$$|H_{\text{lo}}| =$$

$$\angle H_{\text{lo}} =$$

Finally, find the transfer function, magnitude of the transfer function, and phase of the transfer function as ω approaches infinity for E. These should be simplified and expressed in terms of ω where appropriate.

E. (4 points) $V_{\text{out}}/V_{\text{in}} = H_{\text{hi}}(j\omega) =$

$$|H_{\text{hi}}| =$$

$$\angle H_{\text{hi}} =$$

Fall 2003 Solution

Question 1 -- RLC, RL and RC Circuits (30 points)

Shown below are 5 circuits. Assume the input voltage (V_{in}) is applied across the left-most terminals and the output voltage (V_{out}) is measured across the rightmost terminals.

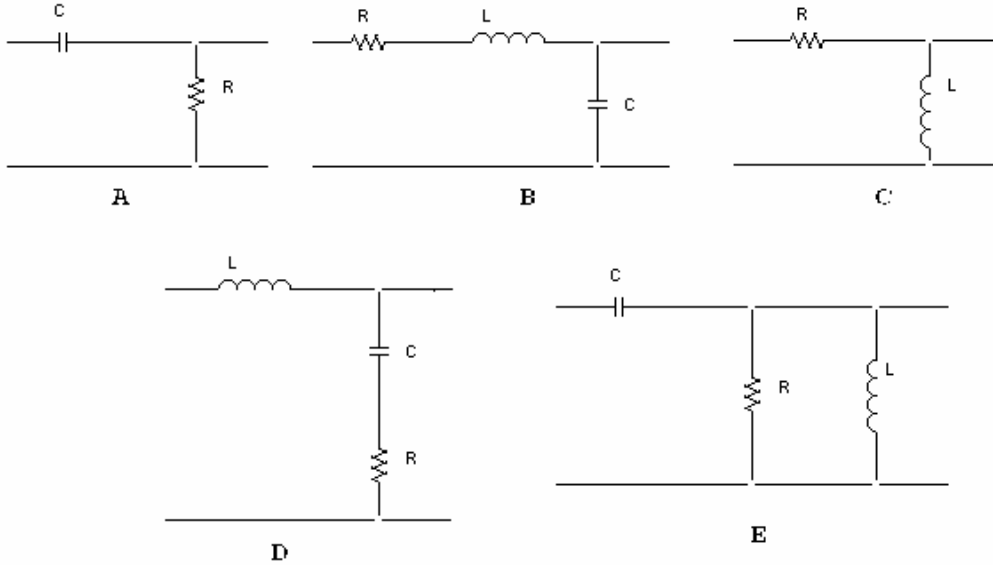

Given below are several possible expressions for generic transfer functions for such circuits. Indicate which circuit goes with which function. (1 point each)

$\frac{j\omega L}{R + j\omega L + \frac{1}{j\omega C}}$	$\frac{R}{R + \frac{1}{j\omega C}} \quad \mathbf{A}$	$\frac{R + \frac{1}{j\omega C}}{R + j\omega L + \frac{1}{j\omega C}} \quad \mathbf{D}$	$\frac{j\omega C + \frac{1}{j\omega L}}{R + j\omega C + \frac{1}{j\omega L}}$
$\frac{\frac{1}{j\omega C}}{R + j\omega L + \frac{1}{j\omega C}} \quad \mathbf{B}$	$\frac{R}{R + j\omega L}$	$\frac{R + j\omega L}{R + j\omega L + \frac{1}{j\omega C}}$	$\frac{R}{j\omega RC + 1}$
$\frac{R}{R + j\omega L + \frac{1}{j\omega C}}$	$\frac{j\omega L}{R + j\omega L} \quad \mathbf{C}$	$j\omega L + \frac{1}{j\omega C}$	$j\omega L + \frac{R}{j\omega RC + 1}$
$\frac{1}{j\omega C}$	$\frac{1}{R + \frac{1}{j\omega C}}$	$R + j\omega L + \frac{1}{j\omega C}$	$\frac{j\omega LR}{R + j\omega L} \quad \mathbf{E}$
			$\frac{1}{j\omega C} + \frac{j\omega LR}{R + j\omega L}$

Find the approximate resonant frequency ω_0 for the RLC circuits and the corner frequency ω_c for the other circuits. That is, write the general expression for each frequency. (1 point each)

A. $\omega_c = 1/RC$

B. $\omega_0 = 1/(LC)^{1/2}$

C. $\omega_c = R/L$

D. $\omega_0 = 1/(LC)^{1/2}$

E. $\omega_0 = 1/(LC)^{1/2}$

Determine the complex transfer function for two of the five circuits (A and B) at the resonant frequency or corner frequency. Be sure your answer is given in terms of R, L, and/or C and does not contain ω . This may seem like an obvious comment, but we want to make sure you have the simplest possible expression. Identify the magnitude and the phase of the transfer function at this frequency.

A. (4 points) $V_{out}/V_{in} = H_c = j \omega_c RC / (j \omega_c RC + 1) = j(RC/RC) / (j(RC/RC) + 1) = j/(j+1)$

$$H_c = j/(j+1)$$

$$|H_c| = 1/(1+1)^{1/2}$$

$$\angle H_c = \pi/2 - \pi/4$$

$$|H_c| = 1/(2)^{1/2}$$

$$\angle H_c = \pi/4$$

B. (4 points) $V_{out}/V_{in} = H_0 = 1/(j\omega_0 RC + 1 - \omega_0^2 LC) = 1/(j(RC/(LC)^{1/2}) - j(LC)^{1/2}/RC)$

$$H_0 = -j(LC)^{1/2}/RC$$

$$|H_0| = (LC)^{1/2}/RC$$

$$\angle H_0 = -\pi/2$$

Determine the transfer function, magnitude of the transfer function, and phase of the transfer function at low frequencies for C and D. These should be simplified and expressed these in terms of ω where appropriate.

C. (4 points) $V_{\text{out}}/V_{\text{in}} = H_{\text{lo}}(j\omega) = j\omega L/R$

$$|H_{\text{lo}}| = 0$$

$$\angle H_{\text{lo}} = \pi/2$$

D. (4 points)

$$V_{\text{out}}/V_{\text{in}} = H_{\text{lo}}(j\omega) = (j\omega RC + 1)/(j\omega RC + 1 - \omega^2 LC) = 1/1 = 1$$

$$H_{\text{lo}}(j\omega) = 1$$

$$|H_{\text{lo}}| = 1$$

$$\angle H_{\text{lo}} = 0$$

Finally, find the transfer function, magnitude of the transfer function, and phase of the transfer function as ω approaches infinity for E. These should be simplified and expressed in terms of ω where appropriate.

E. (4 points)

$$V_{\text{out}}/V_{\text{in}} = H_{\text{hi}}(j\omega) = (-\omega^2 LRC)/[R(1 - \omega^2 LC) + j\omega L] = -\omega^2 LRC / -\omega^2 LRC = 1$$

$$H_{\text{hi}}(j\omega) = 1$$

$$|H_{\text{hi}}| = 1$$

$$\angle H_{\text{hi}} = 0$$

Spring 2003

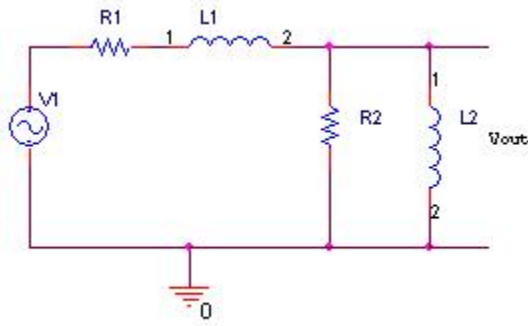

Circuit 1

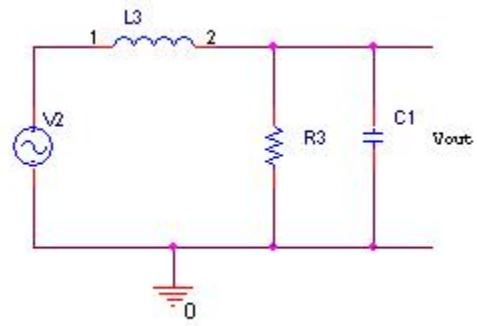

Circuit 2

a) Find the transfer function for circuit 1, $H_1(j\omega)$. Simplify your answer as much as you can. (4 pts)

b) Find the Magnitude and Phase of $H_1(j\omega)$, at low frequencies. (3 pts)

c) Find the Magnitude and Phase of $H_1(j\omega)$, at high frequencies. (3 pts)

- d) Based of what you found, what type of filter is this? (1pts)
- e) Find the transfer function for circuit 2, $H_2(j\omega)$. Simplify as much as you can. (4 pts)
- f) Find the Magnitude and Phase of $H_2(j\omega)$, at low frequencies. (3 pts)
- g) Find the Magnitude and Phase of $H_2(j\omega)$, at high frequencies. (3 pts)
- h) Find the Magnitude and Phase of $H_2(j\omega)$, at resonance frequency. (3 pts)
- i) Based of what you found, what type of filter is this? (1pts)

Spring 2003 solution

1. Transfer Functions (25 pts)

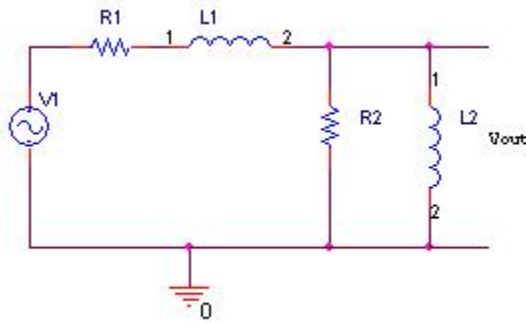

Circuit 1

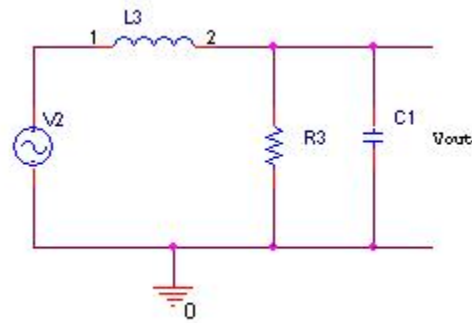

Circuit 2

- a) Find the transfer function for circuit 1, $H_1(j\omega)$. Simplify as much as you can. (4 pts)

$$Z_{R2,L2} = \frac{j\omega R2L2}{R2 + j\omega L2}, \quad Z_{R1,L1} = R1 + j\omega L1$$

$$H(j\omega) = \frac{Z_{R2,L2}}{Z_{R1,L1} + Z_{R2,L2}} = \frac{\frac{j\omega R2L2}{R2 + j\omega L2}}{R1 + j\omega L1 + \frac{j\omega R2L2}{R2 + j\omega L2}} = \frac{j\omega R2L2}{(R1 + j\omega L1)(R2 + j\omega L2) + j\omega R2L2}$$

$$H(j\omega) = \frac{j\omega R2L2}{R1R2 + j\omega R1L2 + j\omega R2L2 - \omega^2 L1L2 + j\omega R2L2}$$

$$H(j\omega) = \frac{j\omega R2L2}{R1R1 + j\omega(R1L2 + R2L1 + R2L2) - \omega^2 L1L2}$$

- d) Find the Magnitude and Phase of $H_1(j\omega)$, at low frequencies. (3 pts)

$$\omega \rightarrow 0 \Rightarrow H(j\omega) \approx \frac{j\omega R2L2}{R1R2} = \frac{j\omega L2}{R1}$$

$$\Rightarrow \begin{cases} |H(j\omega)| \rightarrow 0 \\ \angle H(j\omega) = \tan^{-1}\left(\frac{\omega L2/R1}{0}\right) = \tan^{-1}(\infty) = \pi/2 \end{cases}$$

- e) Find the Magnitude and Phase of $H_1(j\omega)$, at high frequencies. (3 pts)

$$\omega \rightarrow \infty \Rightarrow H(j\omega) = \frac{j\omega R2L2}{-\omega^2 L1L2} = \frac{-jR2}{\omega L1}$$

$$\Rightarrow \begin{cases} |H(j\omega)| \rightarrow 0 \\ \angle H(j\omega) = \tan^{-1}\left(\frac{-R2/(\omega L1)}{0}\right) = \tan^{-1}(-\infty) = -\pi/2 \end{cases}$$

- d) Based of what you found, what type of filter is this? (1pts)

Band-pass

- e) Find the transfer function for circuit 2, $H_2(j\omega)$. Simplify as much as you can. (4 pts)

$$Z_{C1,R3} = \frac{\frac{R3}{j\omega C1}}{R3 + \frac{1}{j\omega C1}} = \frac{R3}{1 + j\omega R3 C1}$$

$$H(j\omega) = \frac{Z_{C1,R3}}{Z_{L3} + Z_{C1,R3}} = \frac{\frac{R3}{1 + j\omega R3 C1}}{j\omega L3 + \frac{R3}{1 + j\omega R3 C1}} = \frac{R3}{(j\omega L3)(1 + j\omega R3 C1) + R3}$$

$$H(j\omega) = \frac{R3}{j\omega L3 - \omega^2 L3 R3 C1 + R3}$$

- h) Find the Magnitude and Phase of $H_2(j\omega)$, at low frequencies. (3 pts)

$$\omega \rightarrow 0 \Rightarrow H(j\omega) \approx \frac{R3}{R3} = 1$$

$$\Rightarrow \begin{cases} |H(j\omega)| = 1 \\ \angle H(j\omega) = 0 \end{cases}$$

The phase is 0, since H is a real and positive number.

- i) Find the Magnitude and Phase of $H_2(j\omega)$, at high frequencies. (3 pts)

$$\omega \rightarrow \infty \Rightarrow H(j\omega) \approx \frac{R3}{-\omega^2 L3 R3 C1}$$

$$\Rightarrow \begin{cases} |H(j\omega)| \rightarrow 0 \\ \angle H(j\omega) = \pi \text{ or } -\pi \end{cases}$$

The phase is π or $-\pi$, since H is a real and negative number.

- h) Find the Magnitude and Phase of $H_2(j\omega)$, at resonance frequency. (3 pts)

$$\omega = \frac{1}{\sqrt{L3 C1}} \Rightarrow H(j\omega) = \frac{R3}{j \frac{L3}{\sqrt{L3 C1}} - \frac{L3 R3 C1}{L3 R3} + R3} = \frac{R3 \sqrt{L3 C1}}{j L3} = \frac{-j R3 \sqrt{C1}}{\sqrt{L3}}$$

$$\Rightarrow \begin{cases} |H(j\omega)| = \frac{R3 \sqrt{C1}}{\sqrt{L3}} \\ \angle H(j\omega) = -\pi/2 \end{cases}$$

The phase is $-\pi/2$, since H is an imaginary and negative number. (We now know that it must be $-\pi$ at high frequencies.)

- i) Based of what you found, what type of filter is this? (1pts)

Low-Pass

Spring 2003

2. Steady State Analysis (25 pts).

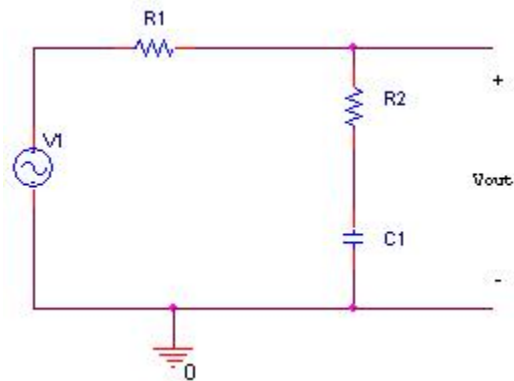

a) Find the transfer function for the above circuit (6 pts).

b) Assume $R1=R2=1K\Omega$ and $C1=1\mu F$, evaluate the magnitude of the transfer function at $\omega = 0$ and $\omega = \infty$. (6 pts)

c) If $v_1(t) = 5v \cos(2\pi \times 1\text{KHz} \times t + \pi/4)$, what is the phasor \vec{V}_1 ? (4 pts)

d) Given $R_1 = 2\text{K}\Omega$, $R_2 = 2\text{K}\Omega$ and $C_1 = 1\mu\text{F}$, what is the output phasor \vec{V}_{out} ? (6 pts)

e) Based on your answer in part d, write the out put voltage in the form of $v_{out}(t) = A \cos(\omega t + \phi)$, i.e. find A, ω and ϕ . (3 pts)

Spring 2003 solution

3. Steady State Analysis (25 pts).

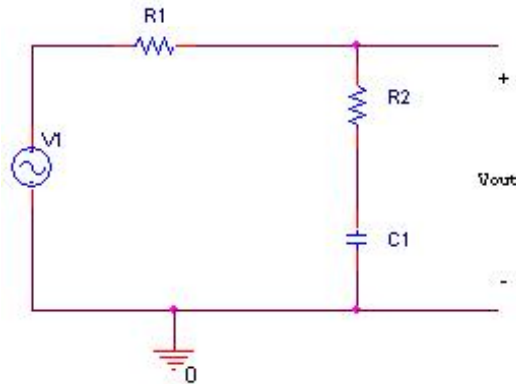

a) Find the transfer function for the above circuit (6 pts).

$$Z_{R_2, C_1} = R_2 + \frac{1}{j\omega C_1} = \frac{j\omega R_2 C_1 + 1}{j\omega C_1}$$
$$H(j\omega) = \frac{Z_{R_2, C_1}}{Z_{R_1} + Z_{R_2, C_1}} = \frac{\frac{j\omega R_2 C_1 + 1}{j\omega C_1}}{R_1 + \frac{j\omega R_2 C_1 + 1}{j\omega C_1}} = \frac{j\omega R_2 C_1 + 1}{j\omega C_1 R_1 + j\omega R_2 C_1 + 1}$$
$$H(j\omega) = \frac{Z_{R_2, C_1}}{Z_{R_1} + Z_{R_2, C_1}} = \frac{j\omega R_2 C_1 + 1}{j\omega(R_1 + R_2)C_1 + 1}$$

b) Assume $R_1 = R_2 = 1\text{K}\Omega$ and $C_1 = 1\mu\text{F}$, evaluate the magnitude of the transfer function at $\omega = 0$ and $\omega = \infty$. (6 pts)

$$H(j\omega) = \frac{j\omega \times 10^3 \times 10^{-6} + 1}{j\omega \times 2 \times 10^3 \times 10^{-6} + 1} = \frac{j\omega \times 10^{-3} + 1}{j\omega \times 2 \times 10^{-3} + 1}$$
$$\omega \rightarrow 0 \Rightarrow H(j\omega) = \frac{1}{1} = 1$$
$$\omega \rightarrow \infty \Rightarrow H(j\omega) = \frac{j\omega \times 10^{-3}}{j\omega \times 2 \times 10^{-3}} = \frac{1}{2}$$

c) If $v_1(t) = 5v \cos(2\pi \times 1\text{KHz} \times t + \pi/4)$, what is the phasor \vec{V}_1 ? (4 pts)

$$\vec{V}_1 = 5e^{j\frac{\pi}{4}} = 5e^{j0.79}$$

d) Given $R_1=2\text{K}\Omega$, $R_2=2\text{K}\Omega$ and $C_1=1\mu\text{F}$, what is the output phasor \vec{V}_{out} ? (6 pts)

$$\omega = 2\pi \times 1\text{KHz}$$

$$H(j\omega) = \frac{j2\pi + 1}{j4\pi + 1}$$

$$|H| = \frac{\sqrt{(2\pi)^2 + 1}}{\sqrt{(4\pi)^2 + 1}} = \frac{6.36}{12.6} = 0.505$$

$$\angle H = \tan^{-1}(2\pi) - \tan^{-1}(4\pi) = 1.41 - 1.49 = -0.08 \text{ or } 6.20 \text{ radians}$$

$$\vec{V}_{out} = H(j\omega)\vec{V}_1 = 0.505 \times 5e^{j(0.79-0.08)} = 2.5e^{j0.71}$$

e) Based on your answer in part d, write the out put voltage in the form

$v_{out}(t) = A \cos(\omega t + \phi)$, i.e. find A, ω and ϕ . (3 pts)

$$v_{out}(t) = 2.5v \cos(2\pi\text{KHz} \times t + 0.71)$$

Fall 2002

1. RLC, RL and RC Circuits (25 points)

Shown below are 5 circuits. Assume the input voltage (V_{in}) is applied across the left-most terminals and the output voltage (V_{out}) is measured across the rightmost terminals (1 point each).

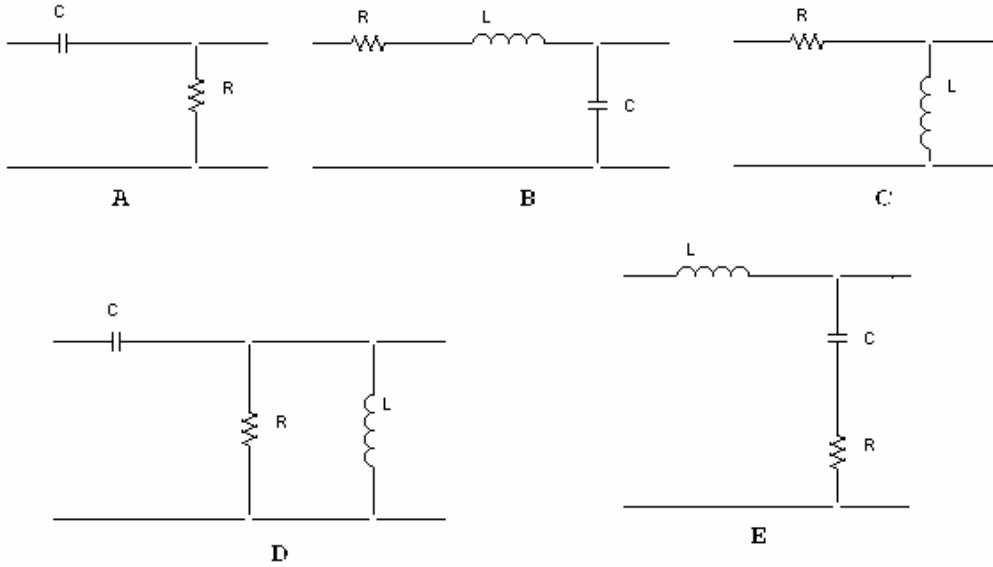

Given below are several possible expressions for generic transfer functions for such circuits. Indicate which circuit goes with which function.

$\frac{j\omega L}{R + j\omega L + \frac{1}{j\omega C}}$	$\frac{R}{R + \frac{1}{j\omega C}}$	$\frac{R + \frac{1}{j\omega C}}{R + j\omega L + \frac{1}{j\omega C}}$	$\frac{j\omega C + \frac{1}{j\omega L}}{R + j\omega C + \frac{1}{j\omega L}}$
$\frac{\frac{1}{j\omega C}}{R + j\omega L + \frac{1}{j\omega C}}$	$\frac{R}{R + j\omega L}$	$\frac{R + j\omega L}{R + j\omega L + \frac{1}{j\omega C}}$	$\frac{R}{j\omega RC + 1}$
$\frac{R}{R + j\omega L + \frac{1}{j\omega C}}$	$\frac{j\omega L}{R + j\omega L}$	$\frac{j\omega L + \frac{1}{j\omega C}}{R + j\omega L + \frac{1}{j\omega C}}$	$j\omega L + \frac{R}{j\omega RC + 1}$
	$\frac{\frac{1}{j\omega C}}{R + \frac{1}{j\omega C}}$		$\frac{j\omega LR}{R + j\omega L}$
			$\frac{1}{j\omega C} + \frac{j\omega LR}{R + j\omega L}$

Find the approximate resonant frequency ω_0 for the RLC circuits and the corner frequency ω_c for the other circuits. That is, write the general expression for each frequency (1 point each).

A.

B.

C.

D.

E.

Determine the complex transfer function for two of the five circuits (A and B) at the resonant frequency or corner frequency. Be sure your answer is given in terms of R, L, and/or C and does not contain ω . This may seem like an obvious comment, but we want to make sure you have the simplest possible expression. Identify the magnitude and the phase of the transfer function at this frequency (6 points).

A. $V_{\text{out}}/V_{\text{in}} = H_c =$

$$|H_c| =$$

$$\angle H_c =$$

B. $V_{\text{out}}/V_{\text{in}} = H_0 =$

$$|H_0| =$$

$$\angle H_0 =$$

Determine the transfer function, magnitude of the transfer function, and phase of the transfer function at low frequencies for C and D. These should be simplified and expressed these in terms of ω where appropriate (6 points).

C. $V_{\text{out}}/V_{\text{in}} = H_{\text{lo}}(j\omega) =$

$$|H_{\text{lo}}| =$$

$$\angle H_{\text{lo}} =$$

D. $V_{\text{out}}/V_{\text{in}} = H_{\text{lo}}(j\omega) =$

$$|H_{\text{lo}}| =$$

$$\angle H_{\text{lo}} =$$

Finally, find the transfer function, magnitude of the transfer function, and phase of the transfer function as ω approaches infinity for E. These should be simplified and expressed in terms of ω where appropriate (3 points).

E. $V_{\text{out}}/V_{\text{in}} = H_{\text{hi}}(j\omega) =$

$$|H_{\text{hi}}| =$$

$$\angle H_{\text{hi}} =$$

Fall 2002 Solution

(not available)

Spring 2002

1. RLC, RL and RC Circuits (25 points)

Shown below are 5 circuits. Assume the input voltage (V_{in}) is applied across the left-most terminals and the output voltage (V_{out}) is measured across the rightmost terminals (1 point each).

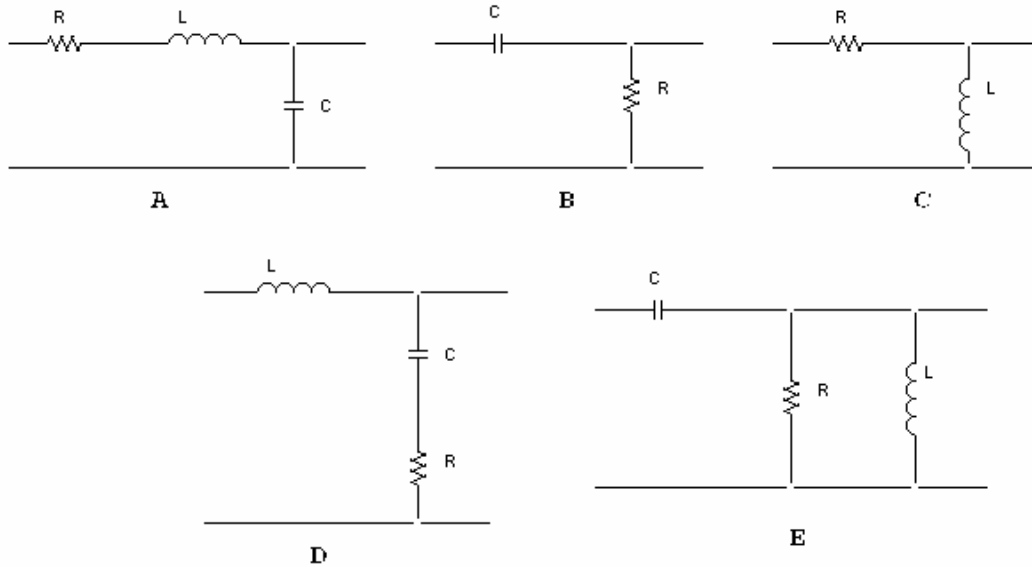

Given below are several possible expressions for generic transfer functions for such circuits. Indicate which circuit goes with which function.

$\frac{j\omega L}{R + j\omega L + \frac{1}{j\omega C}}$	$\frac{R}{R + \frac{1}{j\omega C}}$	$\frac{R + \frac{1}{j\omega C}}{R + j\omega L + \frac{1}{j\omega C}}$	$\frac{j\omega C + \frac{1}{j\omega L}}{R + j\omega C + \frac{1}{j\omega L}}$
$\frac{\frac{1}{j\omega C}}{R + j\omega L + \frac{1}{j\omega C}}$	$\frac{R}{R + j\omega L}$	$\frac{R + j\omega L}{R + j\omega L + \frac{1}{j\omega C}}$	$\frac{R}{j\omega RC + 1}$
$\frac{\frac{1}{j\omega C}}{R + j\omega L + \frac{1}{j\omega C}}$	$\frac{j\omega L}{R + j\omega L}$	$\frac{R + j\omega L}{R + j\omega L + \frac{1}{j\omega C}}$	$j\omega L + \frac{R}{j\omega RC + 1}$
$\frac{R}{R + j\omega L + \frac{1}{j\omega C}}$	$\frac{\frac{1}{j\omega C}}{R + \frac{1}{j\omega C}}$	$\frac{j\omega L + \frac{1}{j\omega C}}{R + j\omega L + \frac{1}{j\omega C}}$	$\frac{\frac{j\omega LR}{R + j\omega L}}{\frac{1}{j\omega C} + \frac{j\omega LR}{R + j\omega L}}$

Find the resonant frequency ω_0 for the RLC circuits and the corner frequency ω_c for the other circuits. That is, write the general expression for each frequency (1 point each).

A.

B.

C.

D.

E.

Determine the complex transfer function for each of the five circuits at the resonant or corner frequency. (1 point each) Be sure your answer is given in terms of R, L, and/or C and does not contain ω . This may seem like an obvious comment, but we want to make sure you have the simplest possible expression. Identify the magnitude and the phase of the transfer function at this frequency. (1 point for each magnitude, 1 point for each phase)

A. $V_{\text{out}}/V_{\text{in}} = H_0 =$

$$|H_0| =$$

$$\angle H_0 =$$

B. $V_{\text{out}}/V_{\text{in}} = H_c =$

$$|H_c| =$$

$$\angle H_c =$$

$$C. V_{\text{out}}/V_{\text{in}} = H_c =$$

$$|H_c| =$$

$$\angle H_c =$$

$$D. V_{\text{out}}/V_{\text{in}} = H_0 =$$

$$|H_0| =$$

$$\angle H_0 =$$

$$E. V_{\text{out}}/V_{\text{in}} = H_0 =$$

$$|H_0| =$$

$$\angle H_0 =$$

Spring 2002 solution

(not available)

Fall 2001 Solution

ENGR4300 Test 2A Fall 2001 Name Solution Section _____

1. RLC Circuits (25 points)

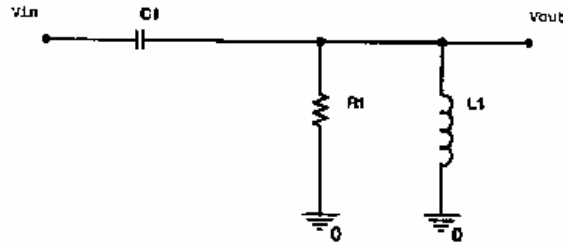

a) Find the complex transfer function for the above circuit

$$Z_{RL} = \frac{Z_R Z_L}{Z_R + Z_L} = \frac{R(j\omega L)}{R + j\omega L} = \frac{j\omega RL}{R + j\omega L}$$

$$H(j\omega) = \frac{Z_{RL}}{Z_C + Z_{RL}} = \frac{\frac{j\omega RL}{R + j\omega L}}{\frac{1}{j\omega C} + \frac{j\omega RL}{R + j\omega L}} = \frac{(j\omega RL)(j\omega C)}{R + j\omega L + (j\omega RL)(j\omega C)}$$

$$= \frac{-\omega^2 RLC}{R - \omega^2 RLC + j\omega L}$$

b) Give an expression for the resonance frequency f_0 .

$$f_0 = \frac{1}{2\pi} \sqrt{\frac{1}{LC}}$$

c) Find the magnitude and phase of the transfer function for the following three cases. Make sure that your answer makes sense with the basic knowledge you have about capacitors and inductors.

i. $f=0 \Rightarrow \omega=0$

$$\omega \rightarrow 0 \Rightarrow H(j\omega) \approx \frac{-\omega^2 RLC}{R} = -\omega^2 LC$$

$$\Rightarrow \left[\begin{array}{l} |H(j\omega)| = 0 \\ \angle H(j\omega) = \pm \pi \end{array} \right]$$

ii. $f = f_0 \Rightarrow \omega = \omega_0$

$$\Rightarrow H(j\omega) = \frac{-\omega_0^2 RLC}{j\omega_0 L} = j \frac{\frac{1}{\sqrt{LC}} RC}{1} = jR \frac{\sqrt{C}}{\sqrt{L}}$$

$$\Rightarrow \boxed{\begin{aligned} |H(j\omega)| &= R \frac{\sqrt{C}}{\sqrt{L}} \\ \angle H(j\omega) &= \frac{\pi}{2} \end{aligned}}$$

iii. $f = \text{Infinity}$

$$\omega \rightarrow \infty \Rightarrow H(j\omega) \approx \frac{-\omega^2 RLC}{-\omega^2 RLC} = 1$$

$$\Rightarrow \boxed{\begin{aligned} |H(j\omega)| &= 1 \\ \angle H(j\omega) &= 0 \end{aligned}}$$

d) Plot the magnitude of the transfer function versus frequency. Make sure that the three points you found above fit on your plot.

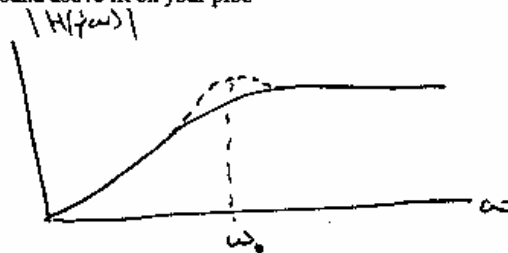

e) Determine if this circuit is a

- a. Low-Pass Filter
- b. High-Pass Filter
- c. Band-Pass Filter
- d. Band Reject-Filter

Why?

Since it passes high freq. and does not pass low freq.