

Project 2 Velocity Estimates

For this project, each team will investigate two approaches to estimating the velocity of the end of the cantilever beam using measurements of acceleration and position. Velocity can be estimated by taking the integral of the acceleration (using an accelerometer) as a function of time or by taking the derivative of the position (using a strain gauge) as a function of time. You are to do both and compare the results.

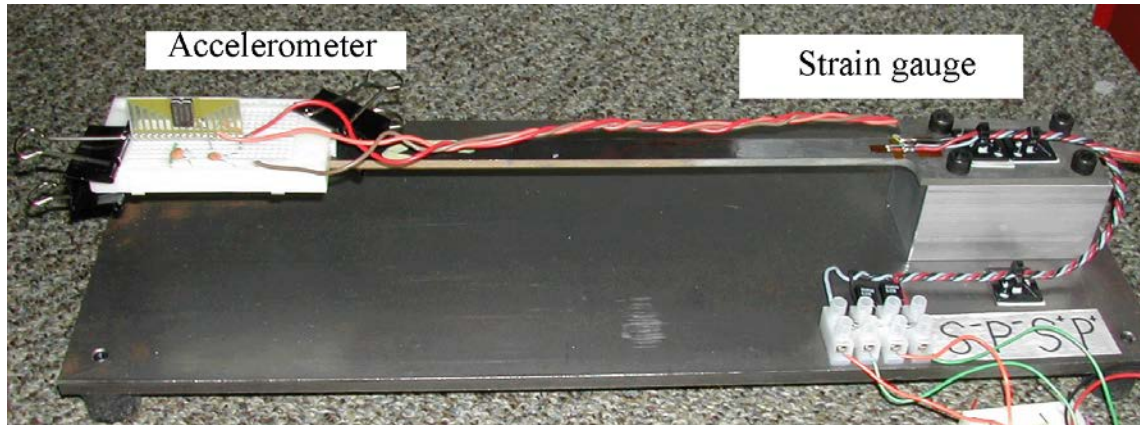

Figure 1.

When you connect these devices to the scope, you get a voltage signal. The strain gauge output is proportional to beam position. The accelerometer gives a signal proportional to the acceleration. We know that the unit of displacement is meters, m; velocity is m/s; and acceleration is m/s^2 . We also know that all of these signals are time dependent functions that look like decaying sinusoids. In this project, we will take data from both devices, calibrate them, convert them into velocity, and compare the results.

Part A of this handout discusses how to use the ADCL327 accelerometer chip (from the kit of parts) to measure the acceleration of the beam directly. Part B discusses methods of calibrating the strain gauge signal, which is proportional to the displacement of the beam. Part C discusses converting both signals to velocity and comparing the results. Appendix I contains a task list for the project. Please note that the handout for the project (Parts A-C) contains background information that you need, but the task list provides the order in which the tasks should be performed. Appendix II contains what your appendix for the project report should contain. Appendix III outlines the project report. For additional background information consult the links and spec sheets on the course links page.

Note: Many groups end up taking their data more than once for this experiment. It is a good idea simply to practice the first time. Get your circuits working. Take practice calibration measurements. Make sure you are absolutely sure you know all the data you need to take. Then, when you are ready, all the data can be taken in about 15 minutes under the same conditions. As in Experiment 5, write down the number of your beam and use the same one throughout the project for more consistent results.

Pre-Lab

Required Reading: Before beginning the lab, at least one team member must read over and be generally acquainted with this document and the other **required reading** materials listed under [Project 2](#) on the EILinks page.

Hand-Drawn Circuit Diagrams: Before beginning the lab, hand-drawn circuit diagrams must be prepared for all circuits physically built and characterized using your instrumentation board.

Board Calibration: If you have an Analog Discovery and haven't done a calibration, do so now. The M2k board does a calibration when you connect to Scopy, but the calibration is only accurate if nothing is connect to the board. It is recommended that you disconnect the multi wire connector when you start Scopy to avoid any load.

Part A - Building an Accelerometer circuit

The following circuit can be used to create a signal proportional to the acceleration of the beam using the ADXL327 accelerometer in the parts kit. Data sheet for [ADXL327](#).

Important note: The ADXL327 needs a 3V power supply, not 5V. 5V may destroy the chip and you only have one. To get 3V:

Analog Discovery: set Wavegen 1 to DC waveform and offset of 3V. Use the W1 wire, yellow, to supply V_s .

M2k board: Signal Generator, channel 1, set to constant with a 3V value. Use the W1 wire, yellow to supply V_s .

Make sure this is set correctly before enabling the Wavegen 1 (Analog Discovery) or the Signal Generator (M2k).

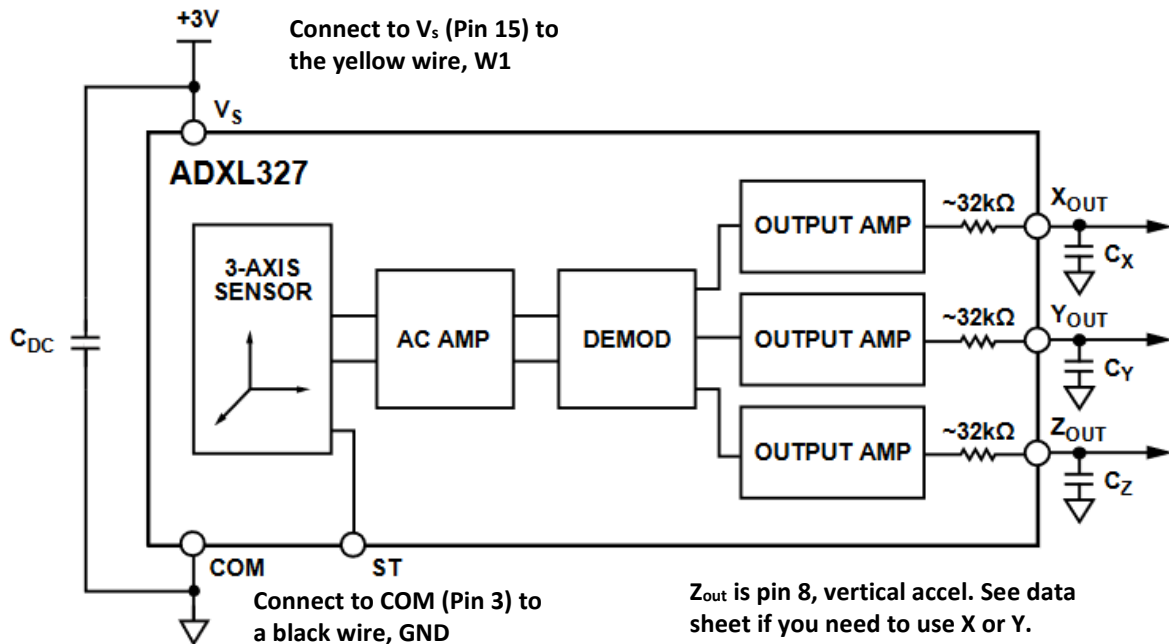

The accelerometer is surface mounted and, thus, cannot be plugged into a protoboard. Therefore, we have mounted the chip on what is called a surfboard. The pin numbering is given in Figure C-4 and a picture of the chip is given in Figure C-5. In the picture (and on the chip), you can see pins 1 and 16 labelled, with the remaining pins labelled consistently with standard chip labelling. For this laboratory, you will be only required to use one of the acceleration directions (the z-direction is likely easiest), though you can investigate the other directions as well.

C_{DC} , C_x , C_y , and C_z are already mounted on the surfboard. You don't need to add any capacitors.

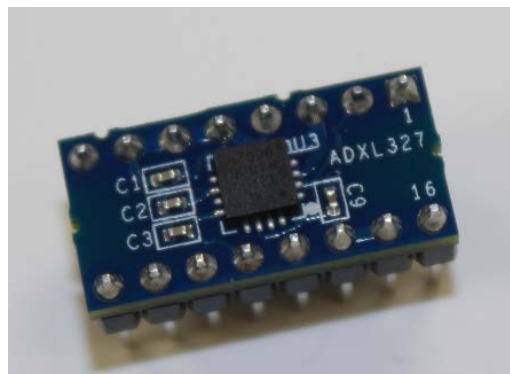
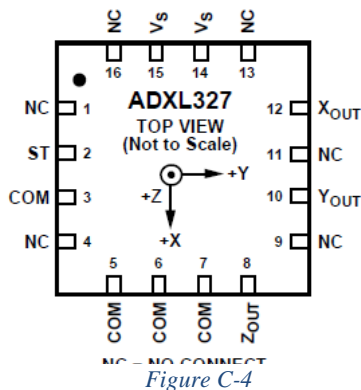

You only need 3 connections between the Analog Discovery/M2k and the accelerometer, +Vs, Ground, and Z_{OUT}. These are pins 15, 3 and 8 respectively. Again remember that +Vs is connected to W1, the yellow wire of the waveform generator/signal generator. Wires from these pins should be as loose as possible so they don't damp the oscillator. This will reduce the effects the wires have on beam motion. The output of the accelerometer is sufficient to be recorded directly with Analog Discovery/M2k. Be very careful with the accelerometer. It is mechanically robust, but the surfboard is not. Also it is electrically sensitive. If you apply the wrong voltages, you may damage it. (Circuit components cannot be repaired). *Please double check your settings before applying power.* To verify that your circuit is working correctly, you can manually move/shake the protoboard. Set your scope to a fairly large time scale. Think of how fast you can manually move the board up and down to estimate the frequency, invert that value to get a period and set your time scale accordingly.

Important Note: As was seen in Experiment 5, the mass on the end of the beam matters. You need to do the measurements with the same mass on the end of the beam. The wires attached to the accelerometer circuit also contribute to the effective mass at the end of the beam. Make sure your wires can move freely to minimize their influence on the data.

Build this circuit and record a voltage trace. Have this verified. Save the trace data in a file. You will use MATLAB to plot the data, see section E of this document on plotting data in MATLAB. You will notice that the beam pluck must be a modest distance to avoid saturation of the accelerometer signal.

Calibration

The signal you get from the accelerometer circuit is not acceleration in m/s². It is a voltage proportional to the actual acceleration. The data sheet for the ADXL327 accelerometer states the sensitivity of the output is 420mV/g where g is the acceleration due to gravity, 9.8m/s². Zero acceleration yields an output midway between ground and the 3V power supply voltage, or 1.5V. Thus, we get:

$$a_b[t] = (V_a[t] - 1.5) \frac{9.8}{0.420} \quad (\text{Equation 1})$$

Using this scale factor, you can calculate $a_b[t]$ in m/s².

The acceleration due to gravity will appear as part of $V_a[t]$. The amount it changes $V_a[t]$ will depend on the angle of your accelerator chip relative to the direction of gravity. In most cases this will just be a dc offset. If your chip is horizontal it will be +420mV or -420mV, assuming you are located on the surface of the Earth.

Part B – Calibrating the Strain Gauge

This section discusses the calibration of the strain gauge and a simple comparison between the strain gauge and the accelerometer.

Circuit

In experiment 5 you built the diff amp circuit to measure the output from the strain gauge bridge. Hopefully this circuit is still intact. Reconnect the circuit below. Be careful building or rebuilding this circuit. It is probably the largest source of troubleshooting problems in this project. *Be sure you have a hand-drawn circuit diagram.* Also, note that channel 1 is no longer connected to this circuit, because it is being used for the accelerometer.

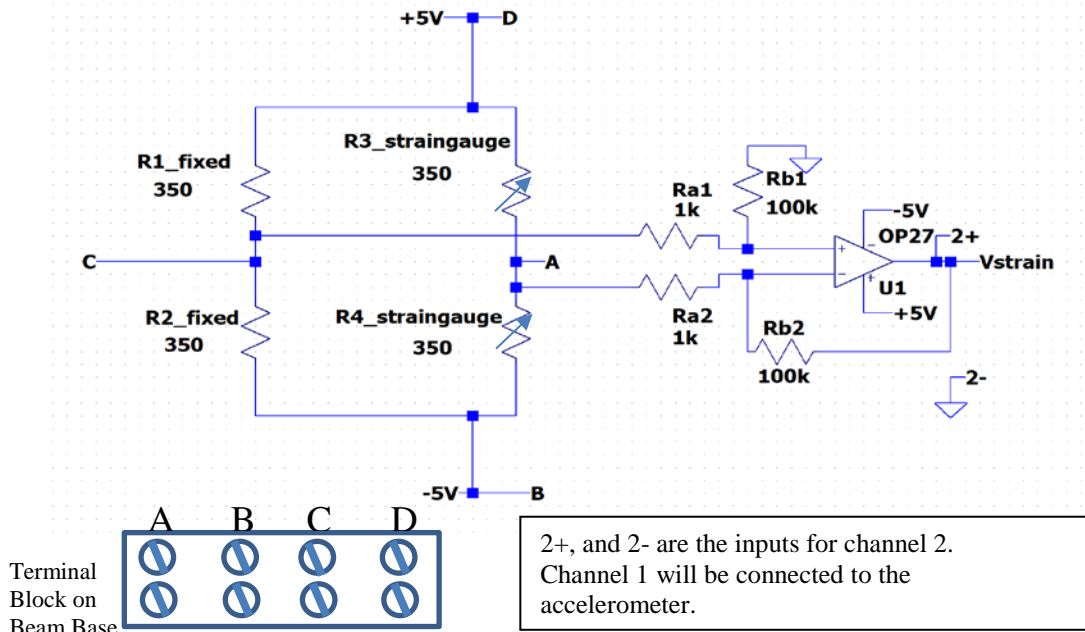

Figure 4. Note: Channel 2 reads the strain gauge signal. Channel 1 will be connected to the accelerometer.

Be sure that the connections on the terminal block make sense before you proceed.

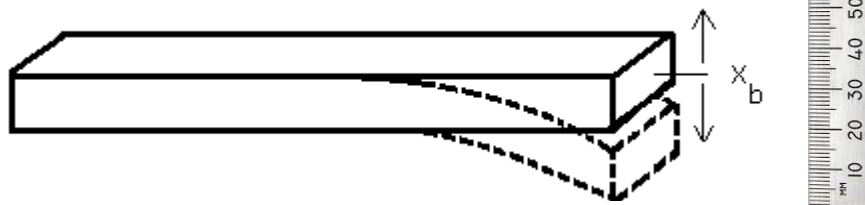

Figure 5.

Calibrate the strain gauge:

Use a ruler and measure the output voltage vs. the displacement of the beam. Take at least 5 measurements. For example, measure V_{OUT} with the beam displaced by -1cm, -0.5cm, 0, 0.5cm and 1cm. You may pick different positions, but don't bend the beam too far or it will be permanently bent. This will void any measurements made before the bending. Plot V_{OUT} vs. position using Excel or MATLAB and fit a line to the data. The slope of the line gives the sensitivity of the strain gauge circuit. Call this constant k_1 . The point where $x = 0$ is arbitrary, so equation 2 can be used to find position of the beam as a function of time. V_{sg} is V_{out} of the strain gauge circuit, k_1 is the constant for the calibration of the strain gauge circuit and x_b is the position of the end of the beam.

$$x_b[t] = V_{sg}[t] \frac{1}{k_1} \quad (equ\ 2)$$

Comparing the strain gauge and the accelerometer signals

Connect channel 1+ of the Analog Discovery to the accelerometer. Connect channel 2+ to the output of the strain gauge circuit. Be sure to ground both 1- and 2-. Record both for one plunk of the beam. Save this data to a file.

The two signals should look similar even though one is proportional to acceleration and one is proportional to position. For the moment, ignore the fact that the oscillation is decaying with time, then:

$$x_b[t] \cong C_1 \sin \omega t \quad (\text{equ 3})$$

therefore

$$v_b[t] \cong C_1 \omega \cos \omega t \quad (\text{equ 4})$$

and

$$a_b[t] \cong -C_1 \omega^2 \sin \omega t = -\omega^2 x_b[t] \quad (\text{equ 5})$$

The signal from the accelerometer should look like the signal from the strain gauge with only a difference in magnitude. Determine ω from the data, and combine this with k_1 (the strain gauge calibration constant) and the accelerometer constant and make a conclusion as to whether the two measurements are in agreement or if something is wrong. (Remember that ω is $2\pi f$.)

Part C – Estimating the velocity

The velocity of the end of the beam is our desired quantity. The velocity can be found by taking the integral of the acceleration signal or by taking the derivative of the position signal. You will do both.

Build the circuits:

You studied practical integrator and differentiator circuits in experiment 4. You now need to build them again to integrate the accelerometer signal and differentiate the strain gauge signal.

Blocking capacitor:

The output of the accelerometer has a DC offset, typically 1.5V + the signal due to gravity. This is a DC voltage and we don't want to integrate DC values, the op amp will saturate. Therefore, a DC blocking capacitor is added to the input of the integrator. As the name implies, this cap will block the DC component of the signal. Below you will be asked to determine if this blocking capacitor changes the behavior of the integrator.

Integrator:

Build the circuit below, using the OP27 op-amp. The power connections aren't shown. As usual, begin by creating your hand-drawn circuit diagram.

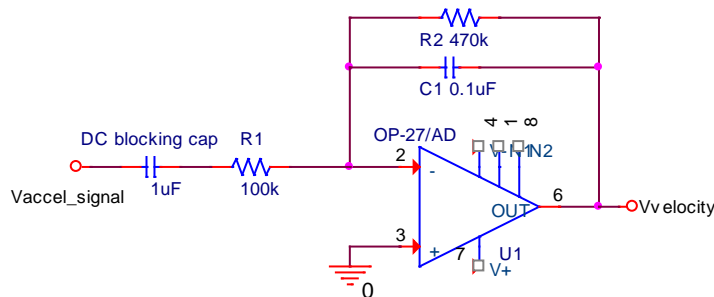

Use V+ and V- on the Analog Discovery/M2k to power the op-amp (+/- 5V). You will then need to use W1 to power the accelerometer chip (+3V).

Figure 2. Power supplies are not shown. This circuit is for OP27 op amp and might not work with the uA741.

The input is the signal from the output of the accelerometer. Connect 1+ to the output of the accelerometer. Connect 2+ to the output of this integrator.

For one plunk save a plot of both channels also export the data to a file. You will use the data in part D. As is discussed below, you need to keep all information needed to be able to plot the acceleration and the velocity in MKS

units. These are: 1) the sensitivity of the accelerometer and 2) the gain of the integrator. As was the case for Exp 5, you might need to use the single trace option in the scope window to collect a good data set. *Make sure that your plucks are small enough to avoid saturating the output of the accelerometer.*

Return to the material for experiment 4 and determine the gain of integrator circuit at the frequency of the beam. Does the circuit function as an integrator? This might be an issue with beams that oscillate at a low frequency such as the ones shown in figure 1. (You may want to test this using the signal generator as a test input to your integrator to be sure.)

Include the plot in your report. Use the data file and all gain factors for Part D.

The values for R1, R2 and C1 were chosen for you. Comment on if these are appropriate. What is the corner frequency for this Miller Integrator? What is the frequency of your beam? At the frequency of the beam oscillations, what is the relative magnitude of Velocity_acc vs. Accel_signal? Is this a good choice, why or why not? Remember also that the DC blocking capacitor is part of the input impedance for the integrator. If the integrator is to be working as designed, the impedance of the blocking capacitor at the beam oscillation frequency must be much smaller than R1. Check to be sure this is the case for the frequency of your beam.

Differentiator:

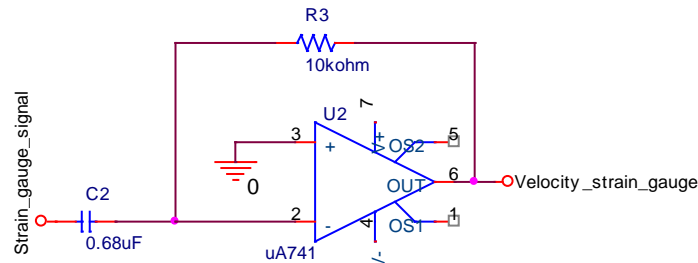

Figure 7. The figure shows a uA741 op amp but use the OP-27 or 741

Build the circuit above but don't take apart either the strain gauge diff amp or the integrator circuit. You will need them all. uA741 op amps are available in the lab. The 0.68 μ F capacitor is labeled as 684, this 68x10⁴pF or 0.68 μ F. The strain gauges should still be connected to the diff amp. The output of the strain gauge diff amp is the input to this circuit. Again, begin by drawing the circuit diagram by hand. Again use the power supplies on the Analog Discovery to power the differentiator.

Connect 1+ to the input of this circuit. Connect 2+ to the output. Record a good signal. Save it to a file. Return to the material for experiment 4 and determine the gain of this circuit at the frequency of the beam. Does the circuit function as a differentiator? (You may want to test this with a function generator to be sure.) Note that it may be very noisy. Why? What can you do to reduce the noise? Add the necessary circuit component(s) to reduce or illuminate the noise. The values of R3 and C2 are given to you. Based on the way that the circuit works and the frequency of the oscillation, were these good choices? Why or why not?

Final data:

For one plunk, record the outputs of both the integration of the accelerometer and the differentiation of the strain gauge signal. Even though one may be noisy, determine if they are in agreement. You will need to include all of the gain constants, which are: 1) the sensitivity of the accelerometer, 2) the gain of the integrator, 3) the sensitivity of the strain gauges with the diff amp, and 4) the gain of the differentiator. As was the case for Exp 5, you might need to use the single trace option in the scope window to collect a good data set.

Additional Questions

In the conclusion of your report, we want you to consider the following:

- Accelerometers are used extensively these days in cars. How would you use accelerometer signals in a car to enhance the driving experience? If there are so many accelerometers in present day cars, why is acceleration typically not displayed for the driver?
- If you had a portable accelerometer, what would you do with it?
- Details about the report conclusion are contained in Appendix III of this handout. You will need to include several MATLAB plots. See Appendix II of this handout for details.

Part D – Plotting data in MATLAB

Start MATLAB

- 1) Importing data
 - a. Click on File menu > Import Data
 - b. Select the file with the data
 - c. MatLab might handle header lines, if not:
 - i. Note in the top right – “number of text header lines”
 - ii. This should be set to at least 1
 - iii. Play with it if you have some extra info at the beginning of your data file
 - d. The default name for the import data is: data
 - e. If you had one channel of the Analog Discovery/M2k active, then you will have n by 2 matrix.
 - i. The first column is the time of each data point
 - ii. The second is the voltage recorded, channel 1
 - f. If you had both channels active, then there is a third column that is data for channel 2.
- 2) Using the data – below are lines from a MATLAB session:

The screenshot shows the MATLAB environment. The workspace contains variables: accel (65792x1 double), colheaders (1x3 cell), data (65792x3 double), sg (65792x1 double), txtdata (1x3 cell), and time (65792x1 double). The Command Window shows the following code and output:

```

>> time=data(:,1); %first column is time array
>> accel=data(:,2); %in this case the accelerometer was on channel 1
>> sg=data(:,3); %the second channel was the strain guage
>> plot(time,accel); % plot the accelerometer vs. time
>> figure(2)
>> plot(time,accel,time,sg); %plot both the accelerometer and the sg data
>> accel=accel-mean(accel); % removes the average, or dc component
>>
  
```

The Command History window shows the same code being executed. The system clock indicates the date 10/10/06 and time 5:34 PM.

Figure 9.

- 3) You need to add annotation to the plots for them to be acceptable. Titles, legends, and appropriate axis settings are expected for the report.

Part E - Appendices

The following appendices summarize what you need to do, what the appendix of your report should contain, and what should be included in your report. Appendix I of this handout gives you a task list of things you need to do. Appendix II of this handout gives you a list of things to include in the appendix of your report. Appendix III of this handout summarizes the parts of the report. In general, every response plot of data generated in the studio should be signed and dated by a TA or instructor and included in the report.

Also be sure to include your **Hand-Drawn Circuit Diagrams** for all circuits physically built and characterized using your Analog Discovery/M2k board.

Appendix I: Task List

A. Build the accelerometer circuit.

1. Put the accelerometer on a protoboard. Clamp it to the beam as near to the end as practical.
2. Test your circuit to make sure that it functions.
3. Use MATLAB to plot the raw data vs. time. **Have this signed.**
4. Convert the raw data and plot acceleration vs. time by including the calibration constant given on page 3 of this project. This can be done outside of class and doesn't need a signature.

B.1 Reconnect your diff amp circuit to the strain gauge.

1. Measure the output voltage while holding the beam at 5 positions. Plot the output vs. position using MATLAB or Excel. Find the slope. This is the calibration constant for the strain gauge.
2. Take a data set just recording the output of the strain gauge circuit, (the strain gauge circuit includes the bridge and the diff amp.) Plot the raw data vs. time using MATLAB. **Have this signed.**
3. Convert the raw data to position and replot. No signature for this plot.

B.2 Record both the accelerometer signal and the strain gauge circuit signal at the same time.

1. Plot both on the same plot using MATLAB. This plot shouldn't include any calibration constants. **Have this signed.**
2. Pick a point of the plots and analyze that point. Apply the calibration constants. Calculate the frequency of the oscillation to determine ω . Show the data points used for this calculation.
3. Determine if equation 5 on page 5 is at least approximately satisfied. Discuss this.

C.1 Estimate the velocity from the acceleration.

1. Build the integrator circuit and connect the accelerator signal to the input.
2. Record the input and output for a plunk of the beam.
3. Plot the raw signals, both on one plot. **Have this signed.**
4. Use the output of the integrator, equation of the integrator and the accelerometer gain constant to plot the velocity as a function of time in real units.

C.2 Estimate the velocity from the position.

1. Build the differentiator circuit and connect the strain gauge circuit output to the input of this circuit. Be sure you modify the circuit in some way to reduce the noise.
2. Record the input and output of the differentiator for a plunk of the beam.
3. Plot the raw signals, both on one plot. **Have this signed.**
4. Use the output of the differentiator, equation of the differentiator, and the strain gauge gain constant to plot the velocity as a function of time in real units.

C.3 Data from both velocity measurements.

1. Record the output of the integrator and the differentiator at the same time for a plunk of the beam.
2. Plot both with all calibration constants included.

- D. Analyze your data and the circuits.
1. Compare the velocity measurements by both methods.
 2. Comment on the effectiveness of the integrator circuit.
 - a. Are the components chosen reasonable. Are there better options?
 - b. Did it work?
 3. Comment on the effectiveness of the differentiator.
 - a. Are the components chosen reasonable. Are there better options?
 - b. Did it work?
- E. Assemble the appendix (as described in Appendix II).
- F. Write your group report (as described in Appendix III).

Appendix II: The Appendix of Your Report

General note: plots that are signed don't need to be nicely formatted. These can have hand notes to indicate what is being displayed. Processed plots, which include the calibration constants, must be professional in appearance.

The following list of items must be included in the appendix of your report, numbered and ordered as listed. This will help make sure that everyone includes everything that is required. In your report you should refer to each appendix specifically as needed to help illustrate your descriptions and conclusions. If you would like, you can include a second copy of what is in the appendix in order to better illustrate what you are trying to say, however, this is not necessary and cannot be used as a replacement for the contents of the appendix.

Appendix A: Accelerometer

1. Plot of raw acceleration data vs. time, **signed**.
2. Plot of acceleration including calibration constant.

Appendix B: Strain and Accelerometer

1. Plot of strain gauge voltage vs. position. Indicate the slope of data.
2. Plot of raw position data vs. time, **signed**.
3. Plot of position vs. time, includes the calibration constant.
4. Plot of raw from accelerometer and strain gauge, **signed**.

Appendix C: Velocity

1. Plot of input and output of the integrator, **signed**.
2. Plot of velocity using the output of the integrator, scaled and labeled.
3. Plot of input and output of the differentiator, **signed**.
4. Plot of velocity using the output of the differentiator, scaled and labeled.
5. Plot of velocity from sensors on the same plunk, scaled and labeled.

Appendix D: References (Must be included.)

1. Names of websites referenced.
2. Title, author, etc. of any books used.
3. Any additional references.

Appendix E: Extra Credit

- Any additional materials you would like to include for extra credit.

Appendix III: Your Group Report (80 points)

General note: plots that are signed don't need to be nicely formatted. These can have hand notes to indicate what is being displayed. Processed plots, which include the calibration constants must be professional in appearance.

Introduction (5 points)

- State the purpose of the project.
- Also include at least 2 topics you studied in this course that helped you understand the project.

Theory (20 points)

- Describe the basic theory. What is the relationship between displacement, velocity, and acceleration? How does the accelerometer measure acceleration? How does the strain gauge measure strain?
- Describe how the circuits work. What are the basic elements of your strain gauge circuit, (bridge and diff amp). Describe the integrator and the differentiator circuits, are the component values reasonable for this task? How did you determine if they were reasonable or not? For what frequencies would the integrator be expected to act like an integrator? The same question for the differentiator. Given the frequency of the beam oscillation – what is the maximum input signal that can be applied to these circuits without causing the output to go into saturation?
- Describe the calibration process. What calibration constants are needed? Where do the constants come from (data sheets or experiment)?
- Describe the gain constants associated with the integrator and differentiator circuits. How are they determined? (Feel free to reference a previous experiment.)
- Use your own words and be sure to site any resources you used in appendix D.
- Demonstrate to the grader that you understand what is happening.

Circuit operation (10 points)

- *Accelerometer circuit*
 - Document the entire accelerometer circuit including the integrator (schematic).
 - Is the output of the integrator consistent with the measured acceleration and the component values used? Amplitude and phase?
 - Include references to relevant material in the appendix.
- *Strain gauge circuits*
 - Document the entire strain gauge circuit, including the bridge, diff amp and differentiator.
 - Is the output of the differentiator consistent with the measured strain and the circuit components used? Amplitude and phase?

Final Analysis and conclusions 11 points)

- *Given the raw signals.*
 - What was the peak acceleration of the beam?
 - What was the peak deflection?
 - If you assume the motion is a pure sin wave, are these traces consistent? Amplitude and phase? If not, speculate why not?
- *Compare strain gauge and accelerometer measurement of velocity.*
 - Is one better suited to determine the velocity? If so, why?
 - What is the peak velocity measured?
 - Do the calculated velocities have the same amplitudes and phases?
 - Explain.
- *How could each measurement be improved? What are the errors associated with each measurement?*
- *State your conclusions on measurements of strain, acceleration and velocity, as they apply to the instrumented beam.*
- *Answer “additional questions” on page 6 of this document.*
- *Include references to relevant material in the appendix.*

- *Discuss any extra credit activities you did and why.*

Personal Efforts (4 points)

- *How were the tasks divided between group members? This is actual efforts not the responsibilities as you reported in the experiments.*

Appendices (20 points)

- *Many of the sections contain points for things included in the appendix.*
- *See Appendix II of this handout.*

Extra Credit (0-5 points) (not common)

- *Include any details that you would like to include about anything you tried above and beyond the basics of the project.*

Your grade will also include a general assessment of project understanding and quality worth up to 10 points. You do not need to write a general assessment.

Total: 70 points for project report
+10 points general assessment
+20 points attendance
100 points

Attendance (20 possible points)

3 classes (20 points), 2 classes (10 points), 1 class (0 points)

Minus 5 for each late

No attendance at all = No grade for project