

Experiment 6 Electronic Switching

Purpose: In this experiment we will discuss ways in which analog devices can be used to create binary signals. Binary signals can take on only two states: high and low. The activities in this experiment show how we can use analog devices (such as op-amps and transistors) to create signals that take on only two states. This is the basis for the digital electronics components we will examine in this experiment.

Background: Before doing this experiment, students should be able to

- Analyze simple circuits consisting of combinations of resistors, inductors, capacitors and op-amps.
- Do a transient (time dependent) simulation of circuits using *LTspice*
- Do a DC sweep simulation of circuits using *LTspice*.
- Determine the general complex transfer function for circuits.
- Build simple circuits consisting of combinations of resistors, inductors, capacitors, and op-amps on protoboards and measure input and output voltages vs. time.
- Review the background for the previous experiments.

Learning Outcomes: Students will be able to

- Set-up and use a transistor as an electrical switch and identify when and why it is ON and OFF.
- Demonstrate that transistors can be used to amplify electrical signals.
- Set-up and use an op-amp as a comparator and identify when and why it changes output state.
- Set-up and use an op-amp as a Schmitt Trigger and identify when and why it changes output state.
- Demonstrate the operation of commercial Comparator and Schmitt Trigger integrated circuits.
- Set-up and operate a circuit that includes a control signal, a digital device and a transistor to control a mechanical relay.

Equipment Required:

- **M2k/Analog Discovery** (with Scopy/Waveforms software)
- **Oscilloscope** (M2k/Analog Discovery)
- **Function Generator** (M2k/Analog Discovery)
- 2N3904 (Transistor), 7414 (Schmitt Trigger), 7404 (Inverter), LED, & the usual components.

Helpful links for this experiment, including *required reading*, can be found on the links page for this course. Of particular importance is the document on *Electronic Switching* (the topic of this experiment).

Pre-Lab

Required Reading: Before beginning the lab, at least one team member must read over and be generally acquainted with this document and the other **required reading** materials listed under [Experiment 6](#) on the EILinks page.

Hand-Drawn Circuit Diagrams: Before beginning the lab, hand-drawn circuit diagrams must be prepared for all circuits that are physically built and characterized using your M2k/Analog Discovery board.

Part A – Transistor Switches

Background

Transistors: A transistor, pictured in Figure A-1, can be used in analog circuits to provide gain or it can be used in digital circuits as an electrically controlled semiconductor switch. We look at the digital, switch, application in this experiment. The switch connects the Collector to the Emitter. The signal at the Base closes and opens the switch.

Note: Pay attention to the connection marked with the red arrow. →
Placing the transistor in the wrong orientation is a common error.

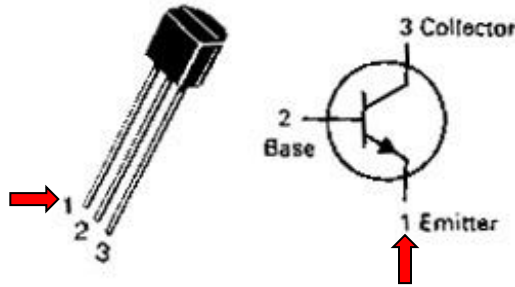

Figure A-1.

In an ideal transistor model, the signal at the Base is not part of the circuit; it simply opens or closes the connection between the Collector and the Emitter. In an npn transistor like the one pictured, when the switch is open, no current flows from the Collector to the Emitter and, when the switch is closed, a current flows from the Collector to the Emitter. Hence, the transistor needs to be oriented in the circuit so that the Collector points towards the source and the Emitter points towards ground. Note that the black arrow in the transistor symbol, located inside the circle on the Emitter leg shows the direction of current flow. To get the switch to open, we place a low voltage at the base (less than about 0.7V). To get the switch to close, we place a high voltage at the Base (greater than about 0.7V). There are different kinds of transistors that have slightly different characteristics. In this course, we use the npn configuration fabricated from silicon.

Transistors have three operating regions. When the voltage across the base-emitter is low, the current is not allowed to flow from collector to emitter. This region is called the *cutoff region*. When the base-emitter voltage is high, the current flows freely from collector to emitter. This is called the *saturation region*. There is also a third region that occurs when the input voltage to the base is around 0.7V. In this region, the transistor is changing state between allowing no current to flow and allowing all current to flow. At this time, the current between collector and emitter is proportional to the current at the base. The region is called the *active region*. Over this small range of voltages, the transistor can be used as a current amplifier.

Experiment

The Transistor: In this part of the experiment, we will use *LTspice* to look at the behavior of a transistor when it is being used as a switch.

- Using *LTspice*, set up the circuit shown in Figure A-2. Note that there are two voltage sources. V_{in} controls the base voltage and V_2 provides voltage at the collector so that current can flow when the switch is closed. For the transistor use the part npn. This is a generic NPN transistor. Right click on the transistor, *Pick New Transistor*, and choose the 2N3904.

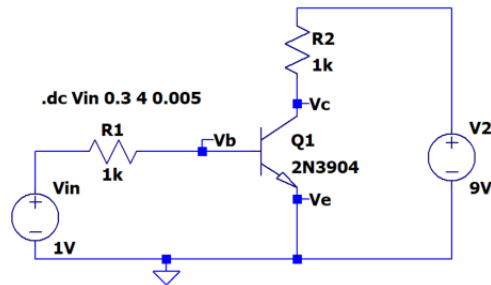

Figure A-2.

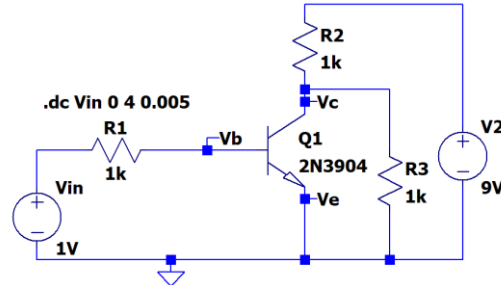

Figure A-3.

- Run a DC sweep simulation. Simulate > Edit Simulation Command > DC sweep
 - Set up a DC SWEEP for V_{in} from 0.3 to 4V (step = 0.005V).
 - Label nodes as V_b , V_c and V_e .
 - Run the simulations and plot V_b and V_c . Note that LTspice the ground voltage and V_e is connected to ground.
 - The transistor Q1 is acting as a switch in the loop with resistor R2 and voltage V2. The voltage V_{in} and resistor R1 are used to turn the switch ON or OFF.
 - The transistor switch will not work exactly like an ideal, simple switch. However, it can be a good approximation to such a switch and, more importantly, it will switch states based on an applied voltage rather than a mechanical act (like turning a switch on and off). Identify on the plot where the transistor is in the cutoff region (OFF) and in the saturation region (ON).
 - Include this plot in your report.
- Now we will consider this switch in a configuration that switches the voltage across a load. In Figure A-2, R2 might be the load and you have already showed that you can switch the current in R2 on and off. But sometimes loads must have one leg tied to ground and in that case the circuit in A-2 won't work. You will now look at a transistor switch for such cases, now R3 is the load and it will be added to the circuit.
 - Add the resistor R3 as shown in Figure A-3 to your circuit.
 - The transistor switch, when open, allows the maximum voltage to occur across R3. When the switch is closed, the voltage across R3 goes to near zero.
 - Run your simulation again and print your output. Include this plot in your report.
 - What is a typical voltage across R3 when the switch is OFF? What is a typical voltage across R3 when the switch is ON? From what you know about voltage dividers, do you think that these values make sense?
- Now we want to take a closer look at the range of V_{in} for which the transistor is in the active region and the switch is neither ON nor OFF.
 - For the circuit in Figure A-3, change the DC SWEEP for V_{in} to range from 0.4V to 0.9V.
 - Plot traces for the ratio of currents into the transistor. If your circuit is labeled as shown, these current ratios are $I_c(Q1)/I_b(Q1)$, $-I_e(Q1)/I_b(Q1)$ and $I_b(Q1)/I_b(Q1)$. These traces are the currents normalized by the base current. The current into the emitter is negative so the normalized trace has minus sign to show the ratio of magnitudes of the currents.
 - You should be able to identify a range of voltages for which the normalized magnitude of the collector and emitter currents are approximately constant and large, ≥ 200 . Use the cursors to find this range. Indicate the range on your plot.
 - Generate the plot and include it with your report.
 - This is the active region for which the transistor circuit acts like a very good amplifier. Here it has a current gain of much more than 100. The gain is not a simple constant, nor is it as large as we can obtain with an op-amp.

Summary

By looking at the operation of a simple transistor circuit, we have seen that there 3 ranges of input voltages for which it looks like: 1) a switch that is OFF, 2) an amplifier, and 3) a switch that is ON.

Part B – Comparators and Schmitt Triggers

Background

Note: The positive power supply for the op amp is often referred to as V_+ or V_{CC} . The negative as V_- or $-V_{CC}$ or V_{EE} .

Comparators: An op-amp can be used to create a binary signal with only two states. With no negative feedback to stabilize its behavior, the output of an op-amp is this huge intrinsic gain (of about 10^6) that multiplied by the voltage difference between the two inputs. If the non-inverting input is slightly higher than the inverting input, the op-amp will saturate in the positive direction. If the inverting input is slightly higher than the non-inverting input, it will saturate negative. The op-amp with no feedback has two states, and therefore, it is a binary device. The value of the output is limited by V_{CC} . Thus, the output should go to about $+V_{CC}$ whenever the net input is positive and to $-V_{CC}$ whenever the net input is negative. The net input is determined by comparing the voltage at the positive (+) terminal, v_p , to the voltage at the negative (-) terminal, v_n . When $v_p > v_n$ then $V_{out} = V_+$ (the positive supply voltage) and when $v_p < v_n$ then $V_{out} = V_-$ (the negative supply voltage.) We call this op-amp configuration a comparator because its state is determined using a comparison of the two inputs. In this experiment, comparators are used to compare an input to some reference voltage, V_{ref} . If the net difference between the input and V_{ref} switches sign, then the comparator will switch state. A comparator can be inverting (when V_{ref} is connected to the non-inverting input) or non-inverting (when V_{ref} is connected to the inverting input).

Schmitt Triggers: Comparators do not give a reliable signal in the presence of noise because the output voltage swings between positive and negative whenever the net input crosses the reference voltage, V_{ref} . It would be more useful to have a comparator-type circuit that switches output state when the net input exceeds some finite threshold buffer around V_{ref} rather than the reference voltage itself. The Schmitt trigger makes this possible. In a Schmitt trigger, T_{upper} and T_{lower} are the upper and lower thresholds that define the buffer area around V_{ref} , and B_{upper} and B_{lower} are constants that define the size of the buffer area. The output of the trigger will switch when the input exceeds $T_{upper} = V_{ref} + B_{upper}$ or is less than $T_{lower} = V_{ref} - B_{lower}$. The size of the buffer area is called the *hysteresis* and it is given by $T_{upper} - T_{lower}$. We can model a Schmitt trigger using an op-amp circuit. In this model, the two thresholds, T_{upper} and T_{lower} , are determined using a voltage divider in the *positive* feedback path of the Schmitt trigger model. Because Schmitt triggers use feedback from the output to create the hysteresis, they are always inverting.

LTspice Experiment

The Comparator: First we will examine the behavior of a simple comparator that changes state when the input goes above or below a constant voltage.

- Build the circuit in Figure B-1 using *LTspice*. Use Sine for V_{in} , set it for 1kHz and an amplitude of 5V.
- Run a transient simulation.
 - Run the simulation from 0 to 3ms with a time step of 1 μ s.
 - Generate a plot of your output, showing the source voltage V_{in} and the load voltage (pin 6 of the op-amp).
 - Include this plot in your report.
 - You can see by closely examining the plot that the point where op-amp output starts to change state isn't exactly where we predict. This is related to non-ideal features of the OP27. But it should be clear that the transition points of interest are when the input crosses 0V.
 - The saturation voltage is the voltage level that the output reaches when the op-amp is saturated. What are the positive and negative saturation voltages of the op-amp?

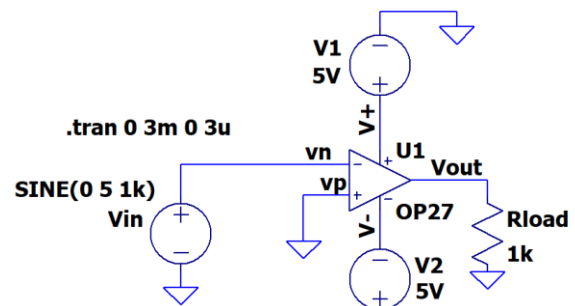

Figure B-1.

- Add a 1V reference voltage to the comparator as shown in Figure B-2 below.

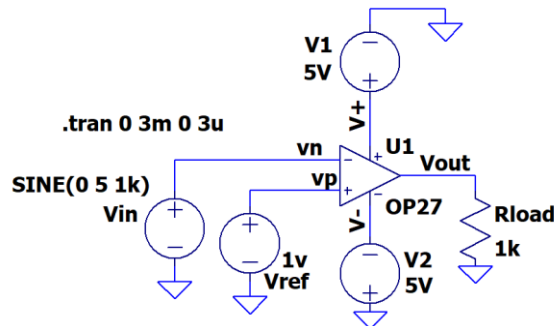

Figure B-2.

- Run a transient simulation.
 - Rerun the simulation from 0 to 3ms with a time step of 1us.
 - Generate a plot of your output, showing the source voltage V_{in} and the output V_{out} (pin 6 of the op-amp). Include this plot in your report.
 - Note the value that the *input signal* is crossing when the comparator starts to change state. Is it at a different input voltage than circuit B-1? How does it compare to the reference voltage of 1V?
 - Now look at the saturation voltages of the output. Are they the same as in circuit B1? Saturation voltages are a characteristic of the op-amp itself, so these should not change.

Schmitt Trigger: Now we will examine a model of a Schmitt trigger.

- Build the circuit in Figure B-3 using *LTspice*.

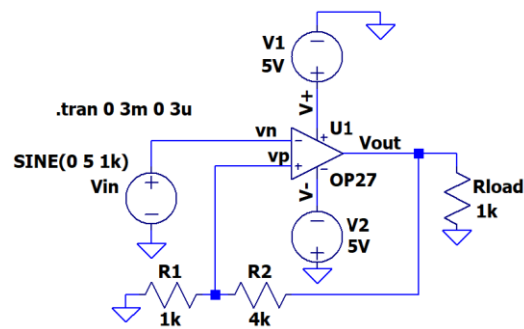

Figure B-3.

- Now simulate this circuit.
 - Use the same transient analysis as above.
 - Generate one plot, again showing the source voltage V_{in} and the output voltage V_{out} . Include this plot in your report.
 - Note: *LTspice* shows a change in the output during the time it is in saturation. This isn't expected in the actual circuit. Any output at $>2.4V$ should be considered positive saturation and $<-2.4V$ is negative saturation.
 - The effective reference voltage for this circuit now depends on V_{out} so there are 2 values called T_{upper} and T_{lower} . What is the value of the input voltage when the output changes state from high to low? What is the value of the input voltage when the output changes state from low to high? These are the values of the threshold voltages for the circuit, T_{upper} and T_{lower} . What is the hysteresis?
 - You can calculate the thresholds, T_{upper} and T_{lower} , from the circuit diagram by using the voltage divider formed by R_1 and R_2 . If the output is saturated positive, at +4V, what will be the voltage at the non-inverting input of the op-amp? The op-amp is comparing the input voltage, V_1 , to this value. This must be the positive threshold, T_{upper} . What happens when the output is saturated negative, at -4V? This is the negative threshold, T_{lower} .

- A Schmitt Trigger can be further generalized by adding a reference voltage to the voltage divider at the non-inverting input. It is called V_{ref_offset} in this diagram. Modify the Schmitt trigger model by adding a 1V source as shown below:

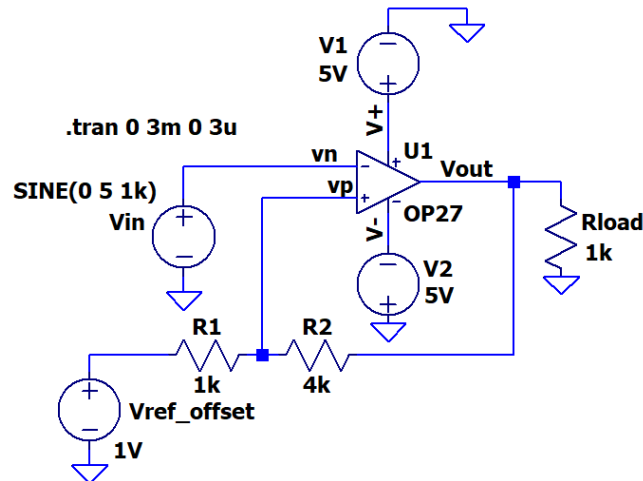
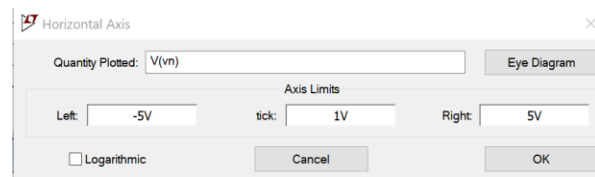

Figure B-4.

- Simulate this circuit.
 - Use the same transient analysis as above.
 - Generate one plot, again showing the source voltage and the output voltage. These are v_n and V_{out} in figure B-4. Include this plot in your report.
 - What is the reference offset voltage for this circuit? Does the output switch states when the input crosses the reference offset voltage? What are the values of the upper and lower thresholds of this circuit? Are they the same as circuit B-3? Why not? What is the hysteresis?
 - You can use a voltage divider to calculate the upper and lower thresholds of this circuit as well. Use the method described in the class notes to do so.
 - It is common to plot comparator performance by plotting V_{out} vs V_{in} , rather than V_{out} vs time and V_{in} vs time. In the Figure B-4 the input voltage can be referenced as $V(v_n)$. That is the label that was given that node. You might have a different name. With plot still on you *LTspice* screen, right click on the horizontal axis. Change the "Quantity Plotted" to $V(v_n)$.
 - Remove the straight line plot of V_{in}
 - Include this plot in your report. It should look like a rectangle. Again don't worry about how V_{out} changes when V_{in} is above 3V or below -3V.
 - Discuss your hysteresis plot of V_{out} vs V_{in} . Do the thresholds match your calculations?



Summary

An op-amp can be used to create binary devices. The comparator, a single op-amp with no feedback, is the simplest of these. The comparator can be used to compare a signal to zero or to any reference voltage. The comparator does not work well in the presence of noise. A more complicated op-amp circuit, that solves this problem, can be created by adding a voltage divider to the non-inverting input of the op-amp. This creates a threshold above and below the reference voltage around which the op-amp will not switch state. Such an op-amp configuration is called a Schmitt trigger.

Part C –Digital Switching

Digital chips: Digital chips are electronic devices that perform logic operations on binary signals. This type of chip forms the basis for all digital computers. There are digital chips that are designed using the same principals as both the Schmitt trigger and the comparator. A *Schmitt trigger inverter* is a digital version of the Schmitt trigger and an *inverter* is a digital version of the comparator. These chips are slightly more restrictive than the op-amp models because they are based on digital conventions. Therefore, by convention, the high power voltage, $+V_{CC}$, is 5V and the low power voltage, $-V_{CC}$, is 0V. The switching voltage lies at a point between low and high. We will examine where this point is in this part of the experiment. Just like op-amps, all digital chips must be supplied with two power voltages, +5V and 0V. Typically these connections are made at the lower left hand corner (0V) and the upper right hand corner (5V) of the chip. Since there must always be power connected *LTspice* does not require that you make them. It just assumes they are made. **On your protoboard, however, you must make the connections.**

The SN7414: The SN7414 chip pictured in Figure C-1 contains six Schmitt trigger inverters. The inputs are designated by nA and the corresponding output by nY, where n is an integer from 1 to 6. Pin 7 is attached to ground and pin 14 is attached to $V_{CC} = 5V$.

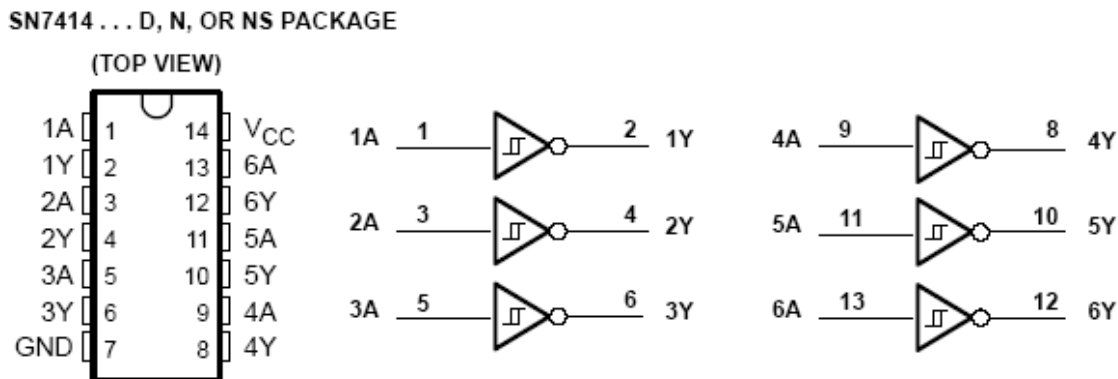

Figure C-1.

The purpose of the Schmitt trigger inverter is to convert an analog voltage into a binary digital voltage. When the input voltage of the SN7414 exceeds a threshold, V_{T+} , the device output switches to LOGIC 0 (0V); the input voltage must drop below a second threshold, V_{T-} , for the output to switch back to LOGIC 1 (5V). The difference in thresholds (called hysteresis) is very important in preventing false triggering on noise. The device is also inverting, but the Schmitt trigger inverter does not behave in the same manner as the inverter. You can find more information about this chip on the spec sheets for the 7414 located on the links page for the course.

The SN7404: This chip contains six inverters. The purpose of the chip is to invert a binary signal. The pinout is exactly the same as the Schmitt trigger inverter, but this chip is not designed to handle analog signals. It assumes the input takes on one of two distinct values: LOW (somewhere near 0V) and HIGH (somewhere near 5V). There is a grey area between a cutoff for LOW, V_{IL} , and a second cutoff for HIGH, V_{IH} . The inverter is not designed to function correctly in this area. You can find more information about this chip on the spec sheet for the 7404 located on the links page for the course.

The PULSE Voltage source: In this experiment, you will need to understand setting the voltage source to a pulse in *LTspice*. You did this in Experiment 3 but now we will go into greater detail on the source. The pulsed source can be used to create trapezoidal pulses, as pictured in Figure C-2. It can also model specialized versions of the trapezoid, such as square waves and triangular waves. The source has several parameters. $V_{initial}$ is the lowest voltage of the pulse (the voltage at the base of the trapezoid). V_{on} is the highest point on the pulse (the voltage at the top of the trapezoid). T_{delay} is an initial time you can set to delay the start of the wave. (This is usually 0.) T_{rise} and T_{fall} stand for “rise time” and “fall time”. These indicate how much time should be spent transitioning from $V_{initial}$ to V_{on} and from V_{on} to $V_{initial}$, respectively. These determine the slope of the sides of the trapezoid. The T_{on} parameter, sometimes called the pulse width, is the time spent at the constant high voltage, V_{on} . This defines the width of the top of the trapezoid. The T_{period} is the period of the whole signal. N_{cycles} can be used to

have allow a limited number of cycles. It is typically left blank which results in continuous pulses. The amount of time between trapezoidal pulses is $T_{\text{period}} - (T_{\text{rise}} + T_{\text{on}} + T_{\text{fall}})$.

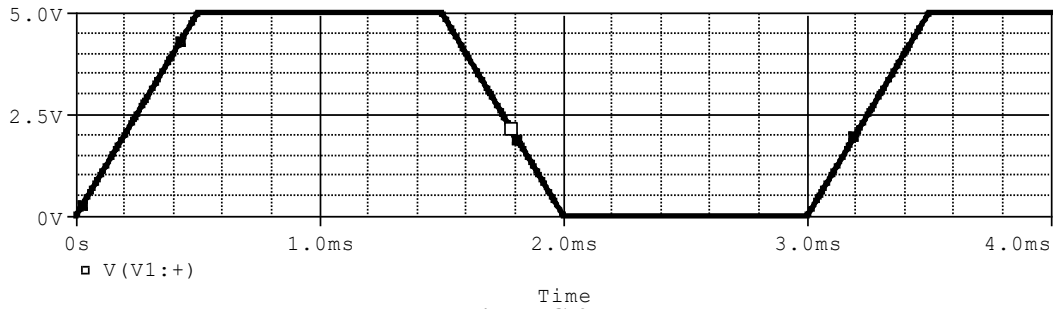

Figure C-2.

For example, in the pulse above, the period is 3ms, the rise and fall times are 0.5ms and the pulse width is 1ms. The PULSE source is chosen by placing a Voltage component on the schematic, right click, and choose PULSE.

LTspice Experiment

Comparing the Schmitt Trigger and the Comparator in the presence of noise: Now we will use *LTspice* to simulate a circuit that uses the SN7404 and the SN7414 to compare the behavior of the inverter to the Schmitt trigger inverter in the presence of noise. We will use two voltage sources to simulate a noisy signal. V1 is the desired signal and V2 is the noise.

- Create circuit in Figure C-3a in *LTspice*. There is a [Digital] library which contains logic gates. Or you can type *inv* for the inverter, *and* for the and gate, ... We will use the *inv* (inverter) to show the behavior of the SN7404 inverter chip and the *schmittinv* (Schmitt trigger inverter) to show the behavior of the SN7414 Schmitt Trigger Inverter chip. See figures C-3b and C-3c.
- The logic gates must be given the trigger levels. This is shown in Figure C-4a and C-4b. Right click on A1 and in the value line type: *Vhigh=4 Ref=1.5* Right click on A2 and in the value line type: *vt=1.5 vh=.5 Vhigh=4*.

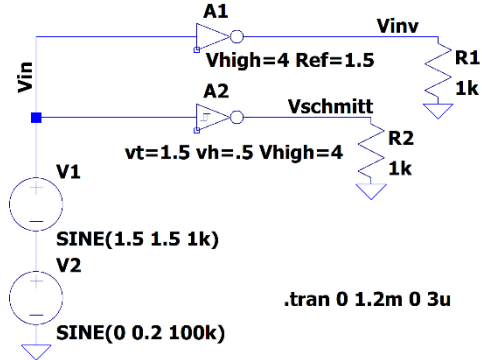

Figure C-3a A1 is a inverter. A2 is an Schmitt Trigger. Run first with a 0V amplitude for V2 (the noise source) then with 0.2V amplitude.

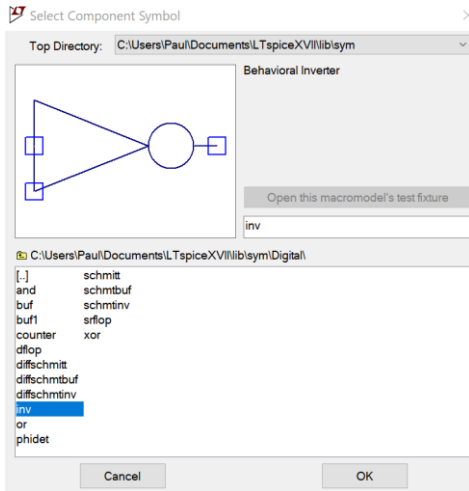

Figure C-3b placing the inverter (SN7404)

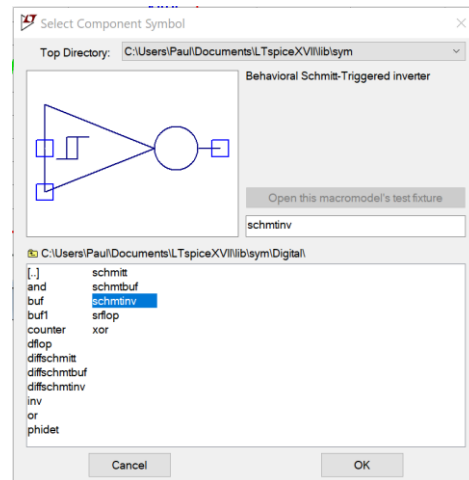

Figure C-3c placing the Schmitt trigger inverter (SN7414)

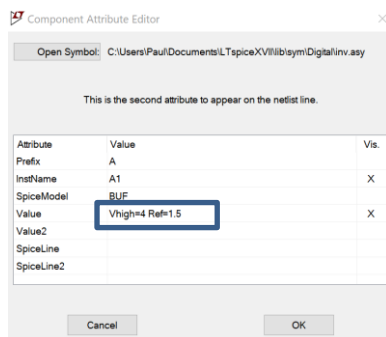

Figure C-4a set parameters for inverter

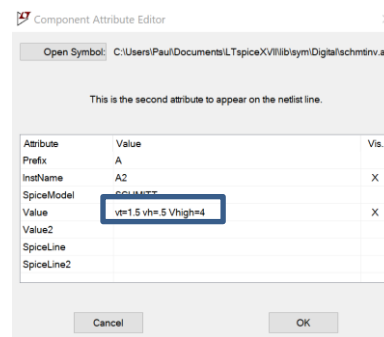

Figure C-4b set parameters for Schmitt trigger inverter.

- The parameters set the levels for the gates.
 - **Vhigh** sets the output voltage of a high (true or logic 1) signal. Vlow by default is zero.
 - **Ref** sets the voltage for the input transition. An input below Ref is considered a logic low, one above Ref is considered a logic high.
 - **vt** set the threshold level for the Schmitt trigger.
 - **vh** hysteresis level. The low transition is at $vt-vh$ and the high transition is at $vt+vh$. What we have been calling the hysteresis is equal to $2*vh$.

Simulate this circuit.

- For V1, use an offset of 1.5V, an amplitude of 1.5V and a frequency of 1kHz.
- For V2, use no offset, **set the amplitude of 0V** and a frequency of 100kHz. Below you will set it to 0.2V
- Run the simulation for 1.5ms using a step size of 1us.
- Plot both outputs along with the input signal. Include this plot in your report. Plot C1.1
- Repeat but now set the amplitude of V2 to 0.2V, Plot the outputs with the input. Include this plot in your report. Plot C1.2
- From Plot C1.1, Check to be sure that the inverter performs as it should by looking up the characteristics of the SN7404 on the links page for Experiment 6 (See page 5: V_{IH} and V_{IL} .) For what range of voltages should the device not invert correctly? For what range of voltages does the inverter in C1-1 provide good logic level output signals? In LTspice the parameters could be adjusted to better match the data sheet but that isn't necessary for this comparison.
- From Plot C1.1 Determine the value of the input voltage when the output of the Schmitt trigger changes state. (Find T_{upper} and T_{lower} .) What is the hysteresis of the Schmitt trigger?
- Check to be sure that the Schmitt trigger device performs as it should by looking up the characteristics of the SN7414 on course links page. (See page 4: V_{T+} , V_{T-} , and hysteresis). What are the typical switching thresholds and hysteresis for this device? Does the LTspice simulation work as expected?
- From Plot C1.2 What is the simulated noise going to the output of the inverter, 7404? Does it affect the output of the Schmitt Trigger, 7414? Does the Schmitt Trigger chip offer advantages if the input has substantial noise?

Using the Schmitt trigger and the inverter to control a transistor switch: In the following simulation, we will use the comparator and the Schmitt trigger to open and close a transistor switch.

- Wire the circuit in Figure C-5 in LTspice. Note that there are two nearly identical circuits in this diagram: one containing an inverter and the other a Schmitt trigger inverter.
 - The VPULSE pulse should range between 0 and 5V. The rise and fall times should be 0.5ms. The pulse on time should be 1ms. The total period should be 3ms.

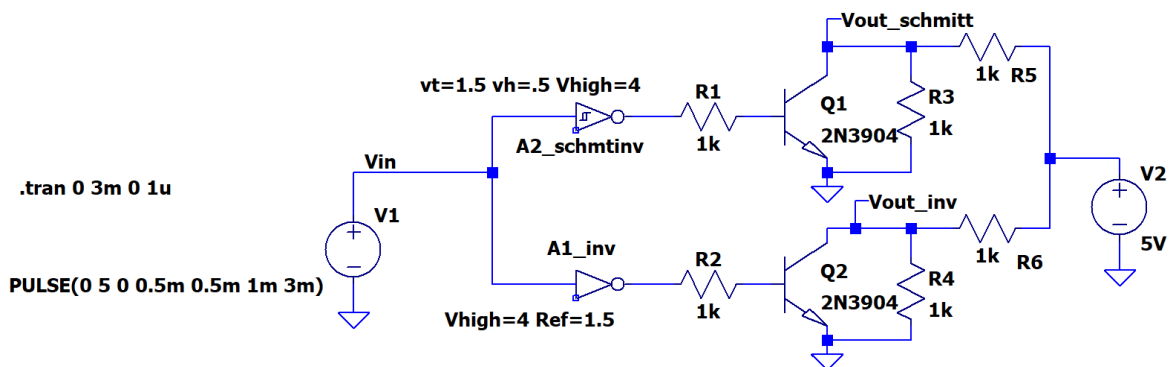

Figure C-5

- Run a simulation.
 - Create a simulation for this circuit. Use a run time of 3ms and a step size of 3us. This should show a single input pulse.
 - Run the simulation. Plot the points labelled as Vin, Vout_schmitt and Vout_inv.

- Mark the locations on the plot where the Schmitt trigger causes transistor Q1 to switch.
 - Mark the locations on the plot where the inverter causes the transistor Q2 to switch.
 - Generate this plot and include it in your report.
 - What is the voltage at the Vout_schmitt marker when transistor Q2 is open? Why is it at this voltage?
- Alter the values of the resistors to change the magnitude of the output voltage.
 - Change R5 and R6 to 100Ω. Also change R3 and R4 to 10kΩ.
 - Rerun the simulation.
 - What happened to the magnitude of the output voltage when transistor Q2 is open? Why did this happen?

Summary

The Schmitt trigger and the comparator are both used in digital circuitry. The Schmitt trigger inverter is used to convert an analog signal to a digital signal. It also inverts the signal. The inverter is used to invert a digital signal. Whereas the Schmitt trigger works as expected in the presence of noise, the inverter does not work well in the area between the range of voltages corresponding to LOGIC 1 and the range of voltages corresponding to LOGIC 0.

Part D – Relay Circuit

Relays: A relay is an electrically operated switch. (See Wikipedia <http://en.wikipedia.org/wiki/Relay>.) A LTspice model of a common configuration is shown in Figure D-1. When no current is flowing through the inductor between the pins connected to the coil, the switch remains in the normally closed (NC) position. However, when current flows through the inductor, it forces the switch to change to the normally open (NO) position. The switch itself is attracted by the electromagnet created by the inductor. When the relay switches state, you can hear a little click.

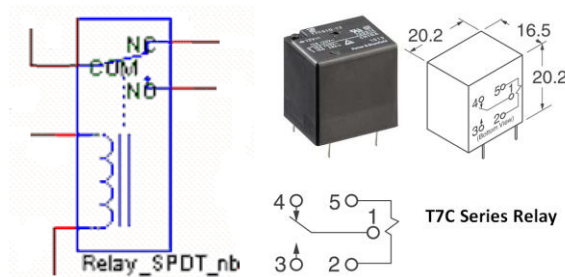

Figure D-1.

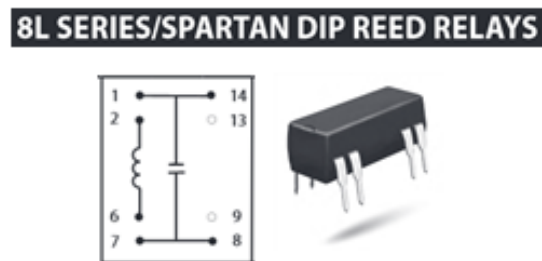

Figure D-2.

The pinouts for two of the relays we use are shown in Figure D-2 (Tyco T7C & Coto 8L series). Depending upon the brand of relay you have, the pinout may be different. All relay manufacturers provide pinout information on their device spec sheets. The Coto is a reed relay, which is also operated by a magnetic field, but generally much smaller than for typical electromechanical relays like the Tyco.

Experiment

Building a switching circuit: To see how practical transistor switches can be, we will use the circuit you simulated in LTspice to show how it can control a relay. **NOTE: You will initially not build the circuit with the relay.** Rather, an LED will be filling in for the relay. LEDs, like all diodes, only work when connected with the correct orientation (see figure D-3).

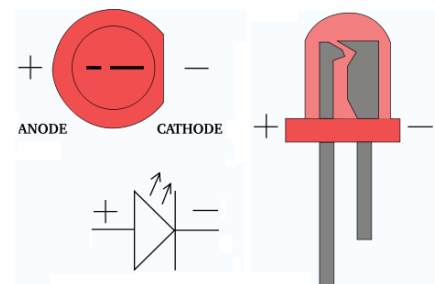

Figure D-3

Figure D-4.1 shows the most standard configuration for a simple relay circuit. There is no need for the resistor usually used to connect between the transistor collector and the +5V source because relay coils have significant resistance. The T7C relay shown above has a coil resistance of 70Ω. The relay coil is also an inductor, so it is necessary to add the diode to protect the rest of the circuit. Recall that anytime

we try to rapidly change the current in an inductor, we get a large voltage spike $V = L \frac{dI}{dt}$. The diode provides a path for the current to ramp down or up more slowly. See <http://electronicsclub.info/diodes.htm>.

- **Build the circuit in Figure D-4.2 on your protoboard. For the transistor, use the 2N3904 in your Parts Kit.**
 - Note that this is half of the circuit you built using *LTspice* in part C with an LED added and no load resistor. The value of the 470Ω resistor is chosen to limit the LED current. You will learn more about this in a future experiment. Instead of building the circuit twice, we can use the fact that both types of inverters have the same pinout and swap the chips in and out to observe their properties.
 - This circuit uses $V_+ = 5V$ power from M2k/Analog Discovery. It also requires a variable input voltage. Here we will use one of the function generators, W1, running at a frequency of 1Hz, for the variable voltage. Set up W1 to produce the same voltage used in the *LTspice* simulation (triangular wave varying from 0V to 3V). Both the input voltages for *LTspice* and M2k/Analog Discovery are shown at the end of this section.

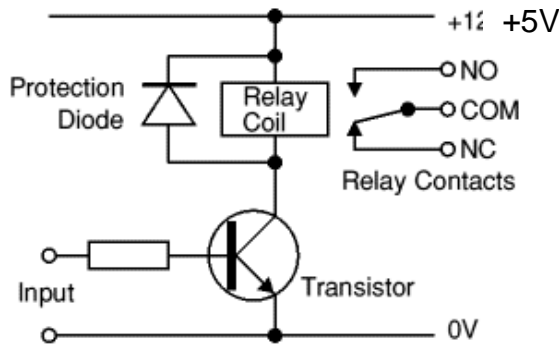

Figure D-4.1

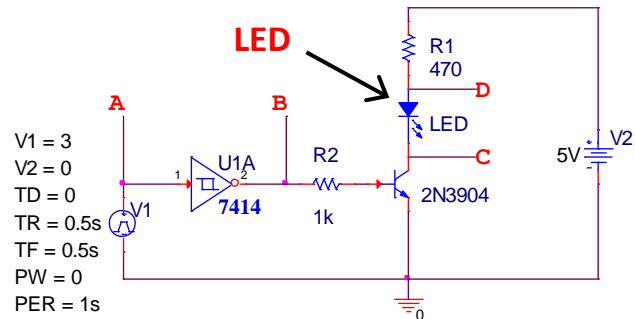

Figure D-4.2

- When the transistor switch is open, there is no current through R2 or D1 and the LED will be off. When the transistor switch is closed, there will be current through R2 and D1 and the LED will be on. What level of input voltage at point A will turn the transistor on and off?
 - At what input voltage V1 did the LED turn off? This gives us T_{upper} .
 - At what input voltage V1 did the LED turn on? This gives us T_{lower} .
 To understand better what it means to be above the upper threshold and below the lower threshold, we will fill out the table below.
 - For an input voltage of 3V (chosen to be above T_{upper}), record the voltage levels at points A, B, C and D in the table below. There are not enough oscilloscope inputs to record all of these voltages simultaneously. You should measure the voltage at A using channel 1+ and then move the connection for channel 2+ to points B, C and D in turn to measure the other voltages. Be sure to connect the M2k/Analog Discovery ground and the negative connections for the two channels (1- & 2-) to your circuit. Save the plots of both channel voltages for each of the three cases and include them in your report.
 - For an input voltage of 0V (chosen to be below T_{lower}) record the voltage levels at points A, B, C, and D in the table.

	A	B	C	D
above upper threshold				
below lower threshold				

LTspice & M2k/Analog Discovery Plots for Figure D-4.2: For completeness, the input voltages for *LTspice* (D-4.2.1) and M2k/Analog Discovery (D-4.2.2) are shown below. Remember that digital devices (logic gates, etc.) work with input and output voltages between 0V and V_{CC} . Thus, the input voltages should not go negative. For the *LTspice* results, the net alias feature was used so that the measured voltages can have well-defined and easy to recognize names. It is a good idea to use this feature if you can.

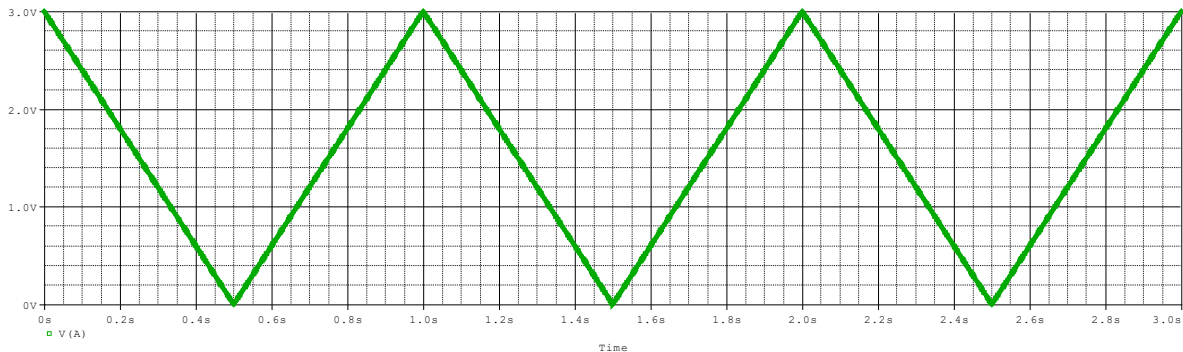

Figure D-4.2.1

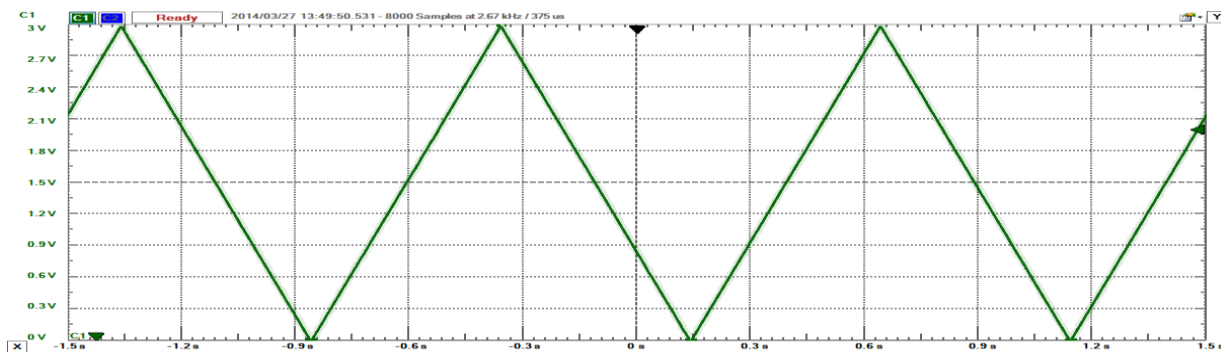

Figure D-4.2.2

Reminder: Be sure to read the document on *Electronic Switching* found under Experiment 6 on the course website.

Identifying Logic Chips: The numbering of chips is not always obvious. Sometimes the numbers are continuous; sometimes they are separated by letters.



Summary

In this part of the experiment we built a circuit using three electrical switches: an inverter, a Schmitt trigger and a transistor. We also considered a mechanical switch: a relay that uses an electromagnet to open and close its contacts.

Checklist and Conclusions

The following should be included in your experimental checklist. Everything should be labeled and easy to find. Credit will be deducted for poor labeling or unclear presentation. ALL PLOTS SHOULD INDICATE WHICH TRACE CORRESPONDS TO THE SIGNAL AT WHICH POINT AND ALL KEY FEATURES SHOULD BE LABELED.

Hand-Drawn Circuit Diagrams for all circuits that are to be analyzed using *LTspice* or physically built and characterized using your M2k/Analog Discovery board.

Part A – Transistor Switches (20 points)

Include the following plots:

1. *LTspice* DC sweep of transistor circuit with cutoff and saturation indicated. (3 pt)
2. *LTspice* DC sweep of transistor circuit with voltage divided. (3 pt)
3. *LTspice* plot of normalized currents with active region marked. (3 pt)

Answer the following questions:

1. Draw a simplified circuit diagram for plot 1 above that includes just V2, R2 and a simple switch to represent the transistor. (2 pt)
2. For your simplified circuit, when the switch is open (OFF), how much voltage will there be at Vc? When the switch is closed (ON), how much voltage will be at Vc? (2 pt)
3. What is a typical voltage across R3 in plot 2 above when the switch is OFF? What is a typical voltage across R3 in plot 2 above when the switch is ON? (2 pt)
4. Why do you think that the values in the previous question 3 make sense? (2 pt)
5. For what range of input voltages did the transistor act like a current amplifier? (Where was there a direct relationship between base current and the current from collector to emitter?) About what was the amplification? (3 pt)

Part B – Comparators and Schmitt Triggers (20 points)

Include the following plots:

1. *LTspice* transient for the comparator with 0V reference voltage. (1 pt)
2. *LTspice* transient for the comparator with 1V reference voltage. (1 pt)
3. *LTspice* transient for Schmitt trigger with 0V reference voltage. (1 pt)
4. *LTspice* transient for Schmitt trigger with 1V reference voltage. (1 pt)
5. *LTspice* plot of Vout as a function of Vin, this is called a hysteresis plot. (1pt)

Answer the following questions:

1. At what input voltage level does the comparator in plot 1. above switch states? (1 pt)
2. At what input voltage level does the comparator in plot 2. above switch states? (1 pt)
3. What are the switching thresholds of the input for the Schmitt trigger in plot 3. above? What is the hysteresis? (3 pt)
4. Use a voltage divider to prove that the values in the previous question 3. make sense. (2 pt)
5. What are the switching thresholds of the input for the Schmitt trigger in plot 4. above? What is the hysteresis? (3 pt)
6. Use a voltage divider to prove that the values in the previous question 5. make sense. (2 pt)
7. Discuss the hysteresis plot, Vout vs Vin. Does it show the expected voltages were the output changes? Why are there 2 possible values of Vout for certain values of Vin? (3 pt)

Part C – Digital Switching (20 points)

Include the following plots:

1. *LTspice* transient of Schmitt trigger and inverter without noise, V2=0, Plot C1-1. (1 pt)
2. *LTspice* transient of Schmitt trigger and inverter in the presence of noise. V2=0.2V, Plot C1-2 (1 pt)

2. *LTspice* transient of Schmitt trigger and inverter switching transistors with transition points marked. Plot C2 (1 pt)

Answer the following questions:

1. From plot C1-1, what input voltage causes a change in the output voltage? (2 pt)
2. How do the values you found for the operating region of the inverter compare to the values of V_{IH} and V_{IL} you found on the spec sheet for the device? (2 pt)
3. From plot C1-1, at what input voltage level does the Schmitt trigger switch from low to high? At what input voltage level does the Schmitt trigger switch from high to low? What is the hysteresis? (2 pt)
4. How do the values you found for the thresholds and hysteresis of the Schmitt trigger compare to the values of V_{T+} , V_{T-} , and hysteresis you found on the spec sheet for the device? (2 pt)
5. From plot C1-2, describe the effects of the noise on both the inverter (7404) and the Schmitt Trigger (7414). Does the Schmitt Trigger offer advantages of input signals with substantial noise? (2 pt)
6. From plot C2, at what input voltage does the transistor switch close and open when using the inverter? (2 pt)
7. From plot C2, at what input voltage does the transistor switch close and open when using the Schmitt trigger? (2 pt)
8. What effect did changing the values of the resistors R1, R2, R4 and R5 have on the output voltage? Why? (2 pt)
9. Why do you think the Schmitt trigger is preferable to an inverter in the presence of noise? (1 pt)

Part D – Relay Circuit (12 points)

Include the following plots (5 pt):

1. Table of data points A, B, C & D.
2. The voltages vs time at points A & B, A & C, A & D for the Inverter.

Answer the following questions:

1. At what input voltage did the Inverter toggle the LED as you increased the voltage? (3 pt)
2. At what input voltage did the Inverter toggle the LED as you decreased the voltage? (3 pt)
3. Is the range found in questions 1 and 2 consistent with your *LTspice* results? (1 pt)

Format (8 points)

1. Organization and completeness of report, information in order of experiments. (8 pt)

List group member responsibilities. (0 to -4pts) Note that this is a list of *responsibilities*, not a list of what each partner did. It is very important that you divide the responsibility for each aspect of the experiment so that it is clear who will make sure that it is completed. Responsibilities include, but are not limited to, reading the full write up before the first class; collecting all information and writing the report; building circuits and collecting data (i.e. doing the experiment); setting up and running the simulations; comparing the theory, experiment and simulation to develop the practical model of whatever system is being addressed, etc.

Summary/Overview (0 to -10 pts) There are two parts to this section, both of which require revisiting everything done on this experiment and addressing broad issues. Grading for this section works a bit differently in that the overall report grade will be reduced if the responses are not satisfactory.

1. Application: Identify at least one application of the content addressed in this experiment. That is, find an engineered system, device, process that is based, at least in part, on what you have learned. You must identify the fundamental system and then describe at least one practical application.
2. Engineering Design Process: Describe the fundamental math and science (ideal) picture of the system, device, and process you address in part 1 and the key information you obtained from experiment and simulation. ~~Compare and contrast the results from each of the task areas (math and science, experiment, simulation) and then generate one or two conclusions for the practical application.~~ That is, how does the practical system model differ from the original ideal? Be specific and quantitative. For example, all systems work as specified in a limited operating range. Be sure to define this range.

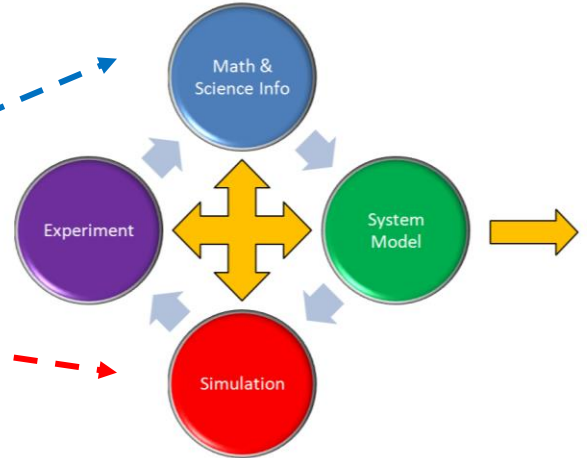

Total: 80 points for experiment packet
 0 to -10 points for Summary/Overview
20 points for attendance
 100 points

Attendance (20 possible points)
 2 classes (20 points), 1 class (10 points), 0 class (0 points)
 Minus 5 points for each late.
 No attendance at all = No grade for this experiment.

Experiment 6

Section: _____

Report Grade: _____

_____ Name

_____ Name

Checklist w/ Signatures for Main Concepts

For all plots that require a staff signature below, you must explain to the TA or instructor:

- the purpose of the data (using your hand-drawn circuit diagram),
- what information is contained in the plot and
- why you believe that the plot is correct.

Any member of your group can be asked for the explanation.

PART A: Transistor Switches

1. *LTspice* DC sweep of transistor circuit with cutoff and saturation indicated
 2. *LTspice* DC sweep of transistor circuit with voltage divided
 3. *LTspice* plot of normalized currents with active region marked
- Questions 1-5

PART B: Comparators and Schmitt Triggers

1. *LTspice* transient for the comparator with 0V reference voltage
 2. *LTspice* transient for the comparator with 1V reference voltage _____
 3. *LTspice* transient for Schmitt trigger with 0V reference voltage _____
 4. *LTspice* transient for Schmitt trigger with 1V reference voltage
 5. *LTspice* of V_{out} vs V_{in} for Schmitt trigger
- Questions 1-7

PART C: Digital Switching

1. *LTspice* transient of Schmitt trigger and inverter without noise.
 2. *LTspice* transient of Schmitt trigger and inverter in the presence of noise _____
 3. *LTspice* transient of Schmitt trigger and inverter with transition points
- Questions 1-9

PART D: Relay Circuit (with an LED filling in for the relay)

1. Table of data points A,B,C and D _____
 2. Input and output voltages for both the Schmitt Trigger and Inverter
- Question 1-3

Group interaction
Summary/Overview