

ENGR-2300

Electronic Instrumentation

Quiz 3

Fall 2012

Name *Solution*Section

Question I (25 points) _____

Question II (25 points) _____

Question III (25 points) _____

Question IV (25 points) _____

Total (100 points) _____

On all questions: SHOW ALL WORK. BEGIN WITH FORMULAS, THEN SUBSTITUTE VALUES AND UNITS. No credit will be given for numbers that appear without justification. Read the entire quiz before answering any questions. Also it may be easier to answer parts of questions out of order.

Some Additional Background

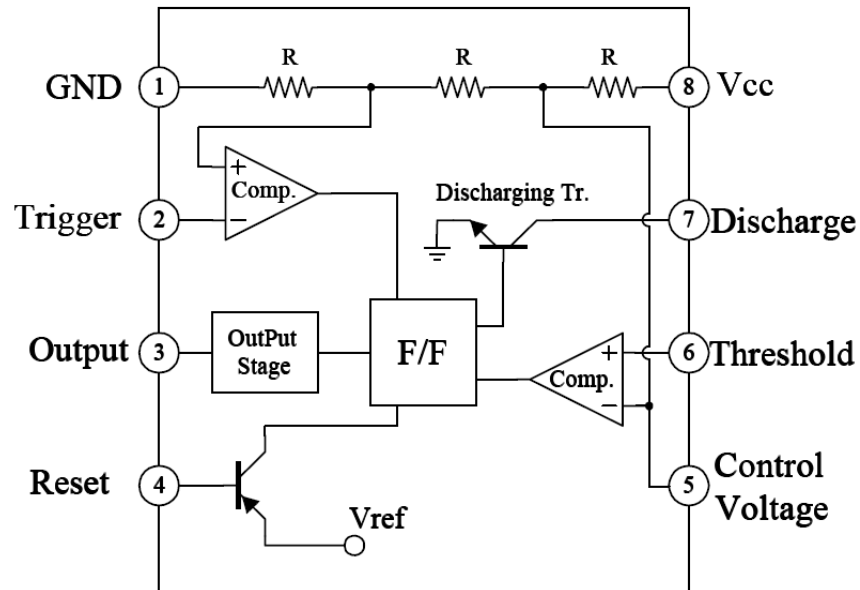

14 November

On this date in 1957, Henry Aaron of the Milwaukee Braves won the National League MVP. The Braves also beat the Yankees in the World Series that year. This was a great year for Braves' fans. Shown at the right is an Aaron baseball card. Do you see anything wrong with it?

1957 World Champion Milwaukee Braves



The picture is printed backwards. Aaron was right-handed and the number 44 is backwards. The letter M is fine.

Question 1 (25 Points) Astable Multivibrator (An iconic 555 timer application)

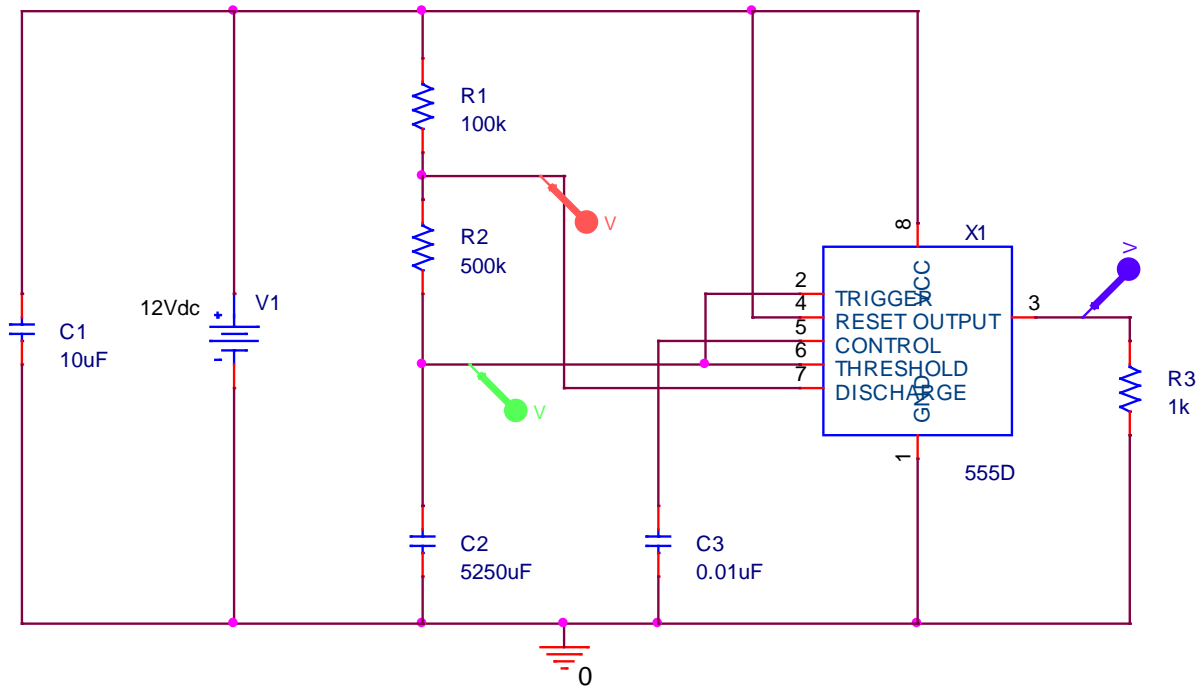

- a. A 555 timer, astable multivibrator is built as shown above. Determine the on time (T_1) and the off time (T_2) for this circuit. (6 points)

$$T_1 = 0.693(R_1 + R_2)C_2 = 2.18\text{ks}$$

$$T_2 = 0.693R_2C_2 = 1.82\text{ks}$$

- b. Plot the output voltage below, showing two full cycles. Label the horizontal and vertical scales. (7 points) *Any output voltage between 8V and 12V is OK for the solution. It should be a Volt or two below Vcc but you only have your experience with the experiment for this info.*

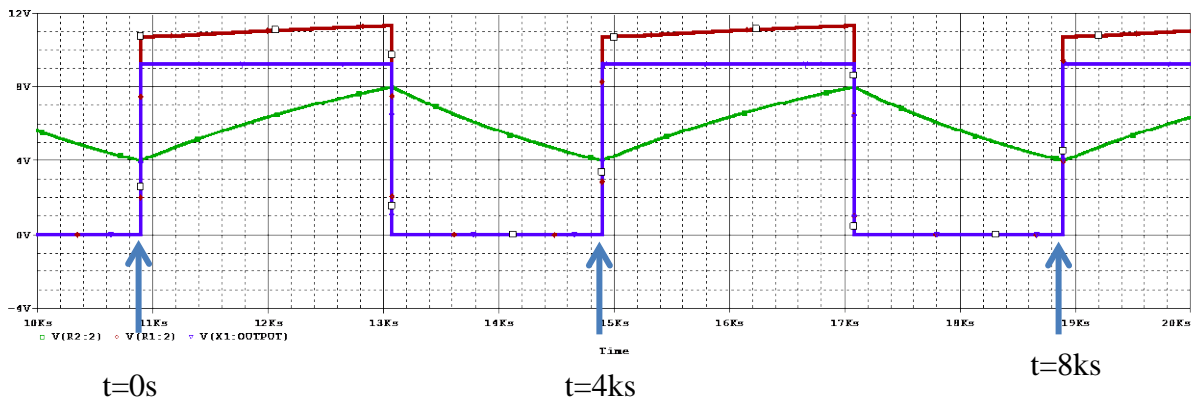

- c. Determine the maximum and minimum voltages at pins 6 and 7. Assume that the circuit is in steady state. (6 points)

For 6: The max is $2/3 V_{cc}$ and the min is $1/3 V_{cc}$.

For 7: The min is $1/3 V_{cc} + (5/6)(2/3)V_{cc} = 10.67V$ which is the minimum while at voltage. However the actual minimum is zero. Either answer is OK.

The max is $2/3 V_{cc} + (5/6)(1/3)V_{cc} = 11.33V$

- d. Plot two cycles of the voltage at pin 6. Label the vertical and horizontal scales. (6 points)

This information is included in the plot above.

Question 2 (25 Points) Combinational Logic Circuits

- a. The following circuit is configured using only NAND gates. Fill in the truth table for this circuit. (8 points)

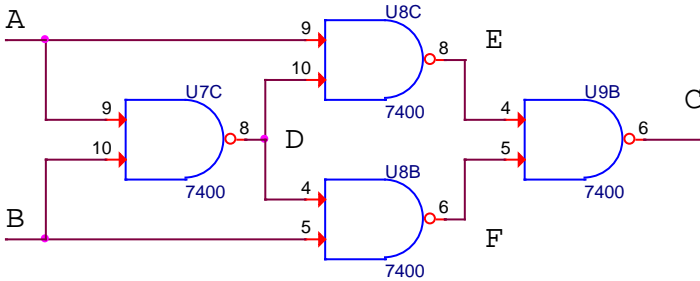

A	B	C	D	E	F
0	0	0	1	1	1
0	1	1	1	1	0
1	0	1	1	0	1
1	1	0	0	1	1

- b. This circuit produces the same result as a standard logic device. What device is it? (7 points)

XOR

- c. A new circuit is built, based on the circuit above, again only using NAND gates. Fill in the truth table below. *Hint: you may want to label some or all other nodes in the circuit and determine them. Which nodes you choose to determine are up to you, but being as complete as possible will permit more opportunities for partial credit. Be sure to label things clearly.* (10 points)

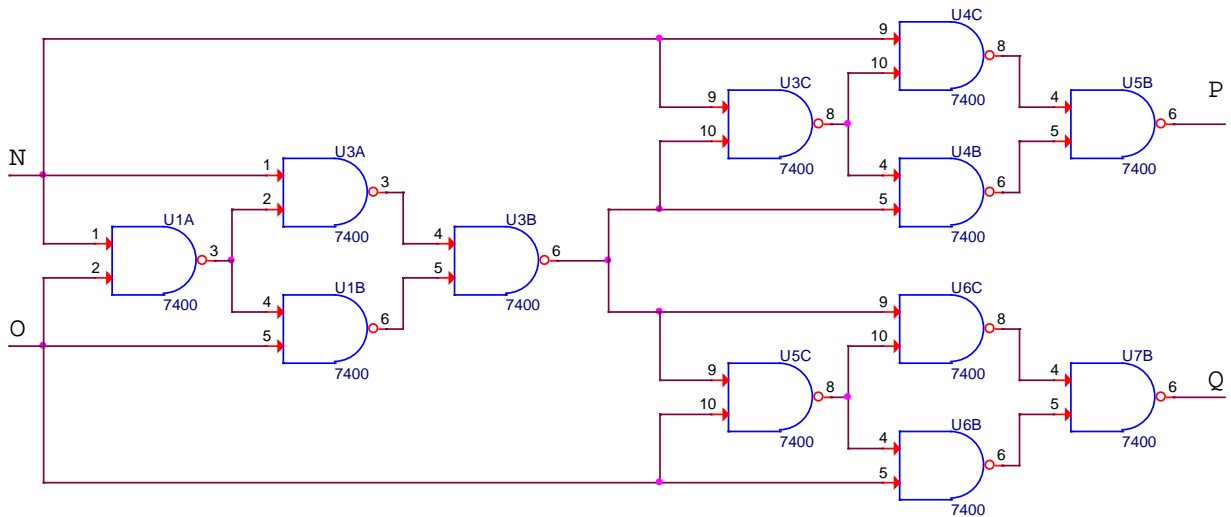

N	O	P	Q	R										
0	0	0	0	0										
0	1	1	0	1										
1	0	0	1	1										
1	1	1	1	0										

Because the NAND gate configuration above is an XOR, we can simplify the circuit above with the one below. Then we only need to find one intermediate node value at R.

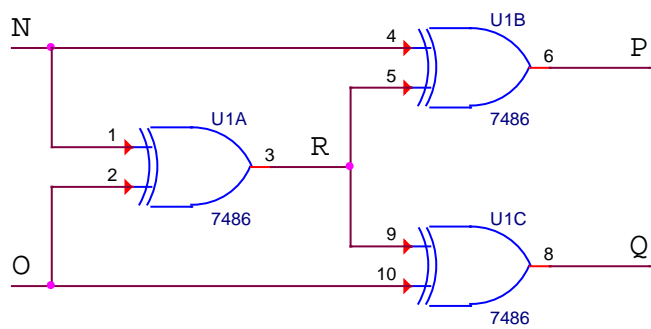

Question 3 (25 Points) Combinational Logic

The following circuit is configured using a variety of logic components. Complete the two timing diagrams below. The first is for the counter alone, nodes C - F. (12 points) The second includes all components, but you only need to plot nodes G - Q. (12 points) *All devices respond on the trailing edge of the pulses. The time scale goes from 0 to 30 ms.*

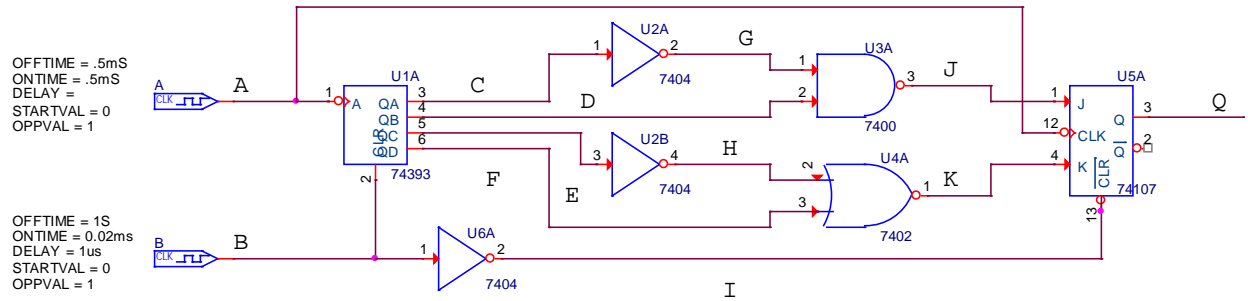

a. Counter Alone *Shown on next page*

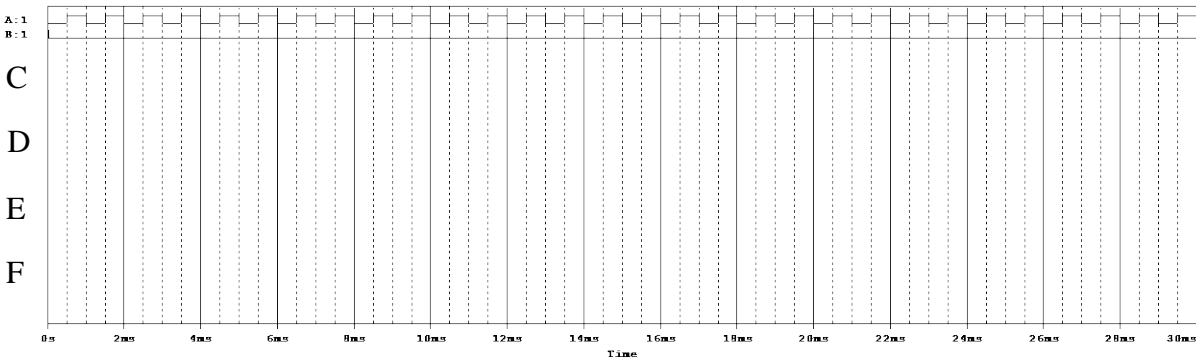

b. Entire Circuit *Shown on next page*

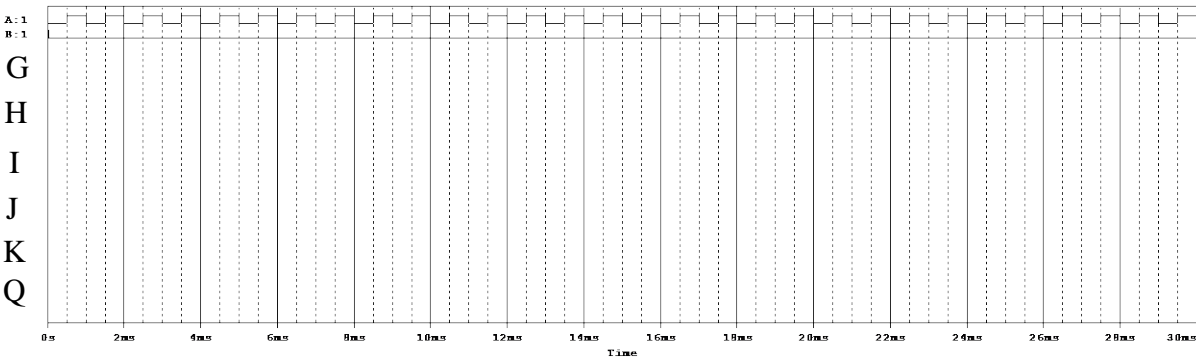

c. What is the meaning of the following sentence? *There are only 10 kinds of people ... those who understand binary and those who do not.* (1 point)

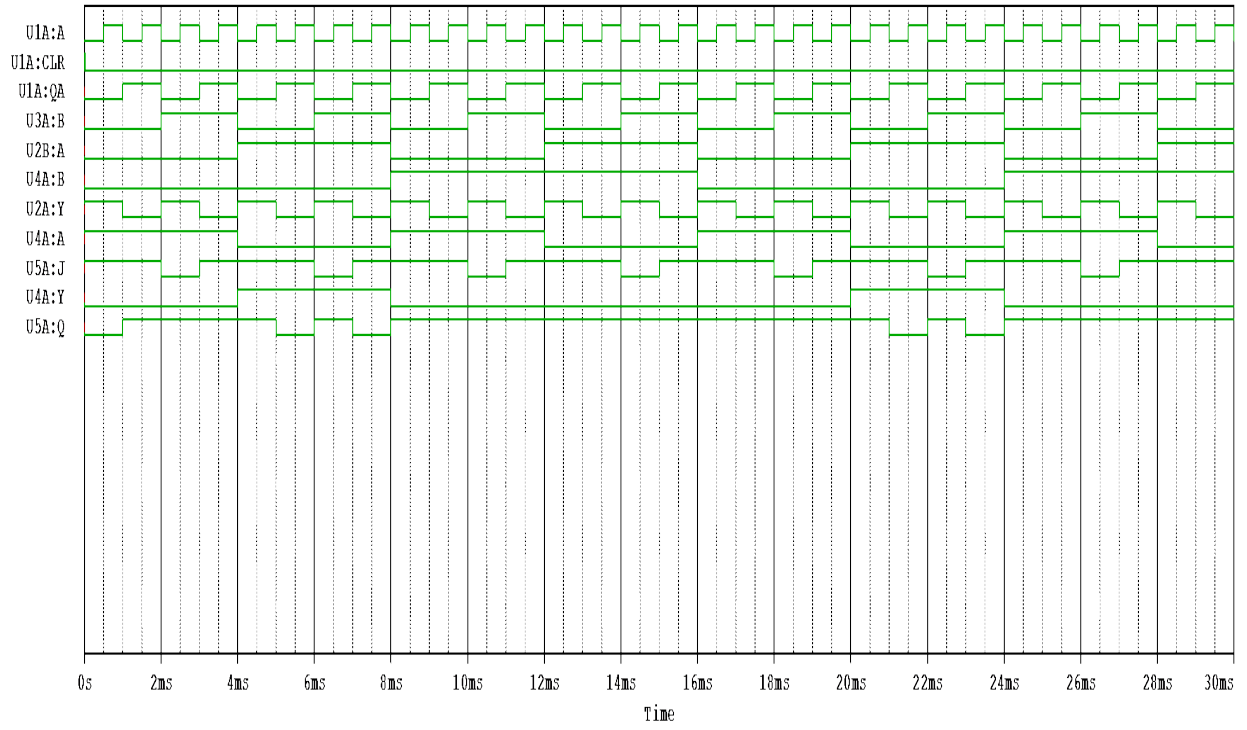

Question 4 (25 Points) Schmitt Trigger

A sequence of triangular pulses is passed through a homemade Schmitt Trigger, as shown below along with a plot of the three pulses vs. time.

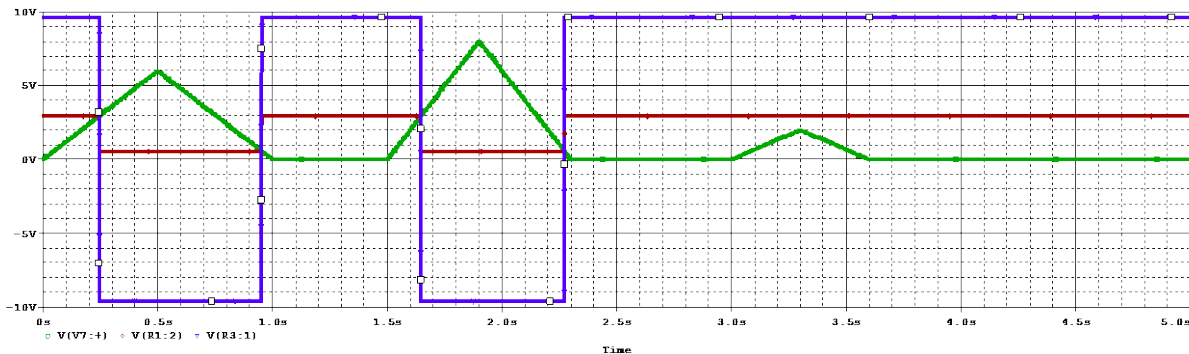
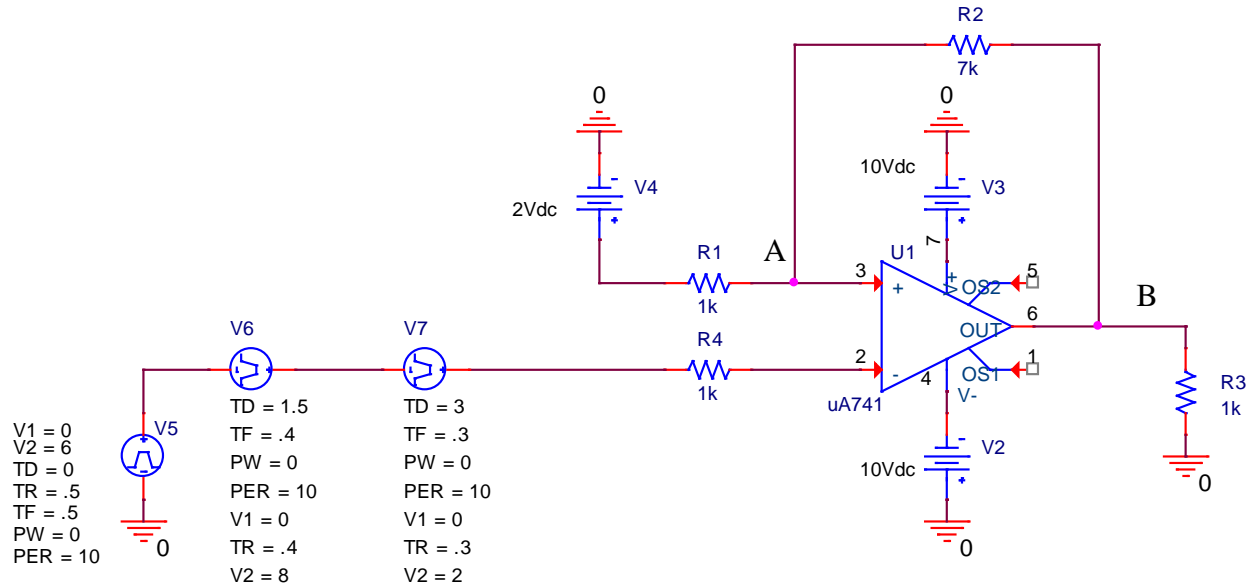

- a. Assume ideal conditions, what are the two threshold voltages for the Schmitt Trigger? (10 Points)

Upper threshold is $2V + (1/8)(10-2)V = 3V$

Lower threshold is $2V + (1/8)(-10-2)V = 0.5V$

- b. Plot the voltages at points A and B vs. time on the plot above. (10 Points) Be sure to clearly label the two voltages.

Blue is output B and red is the switching thresholds A. Note that at $t = 0$, the voltage sources connected to the negative input (pin 2) add up to 0V, while the voltage at the positive input (pin 3) is 2V and, therefore, the output voltage (pin 6) immediately goes to 10V. Thus, the first threshold crossed by the input pulse is determined by a positive

output voltage (i.e. it is 3V). When the voltage at pin 2 passes 3V, the output shifts to its negative value, etc. To see that this would repeat over and over, we can change the input pulse timing a little as shown below. Therefore, it is not reasonable to assume that the output starts at the negative value.

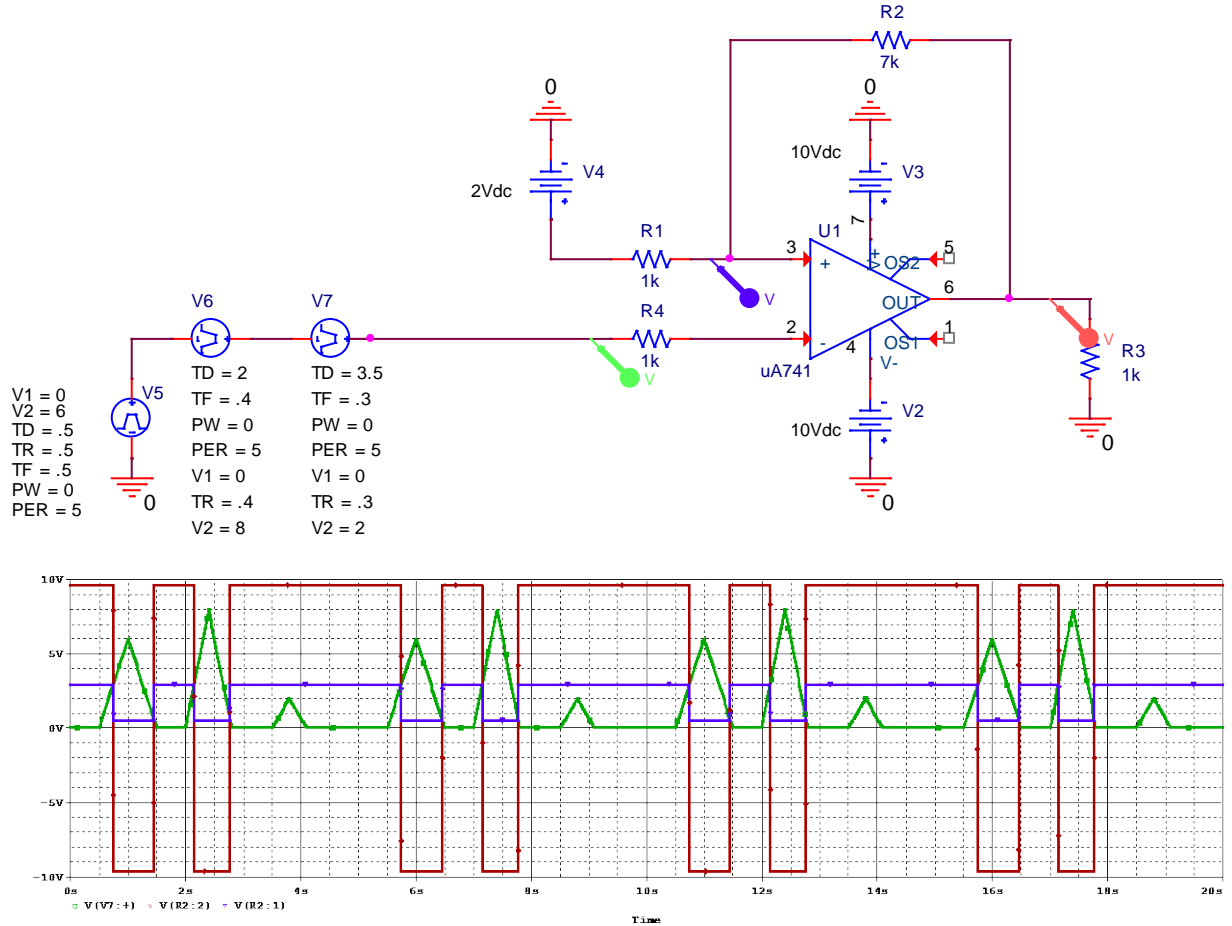

- c. If you are using this as a counter, how many pulses does this circuit count? (5 Points)
Only the first two pulses are counted because the third does not exceed the upper threshold.