

ENGR-2300  
Electronic Instrumentation  
Quiz 2, Spring 2019

Name: \_\_\_\_\_ **Solution** \_\_\_\_\_  
Please write your name on each page

Section: 1 or 2

4 Questions Sets, 20 Points Each  
LMS Portion, 20 Points

- |                 |                                       |
|-----------------|---------------------------------------|
| Question Set 1) | Thevenin Equivalent Sources           |
| Question Set 2) | More Thevenin with Op Amps            |
| Question Set 3) | Operational Amplifiers                |
| Question Set 4) | Damped Sinusoids and<br>Miscellaneous |

On all questions:

**SHOW ALL WORK. BEGIN WITH FORMULAS,  
THEN SUBSTITUTE VALUES AND UNITS.**

No credit will be given for numbers that appear without justification.  
Unless otherwise stated in a problem, provide 3 significant digits in answers.  
It may be easier to answer parts of questions out of order.

If you need extra room, make it clear in the main problem statement that work is  
continuing on the back of the page.

### Question Set 1) Thevenin Equivalent Sources (20 pnts)

For the following circuit, show all work using resistor variable names (e.g. R1, R2, R3, R4, and RL) before substituting resistance values:

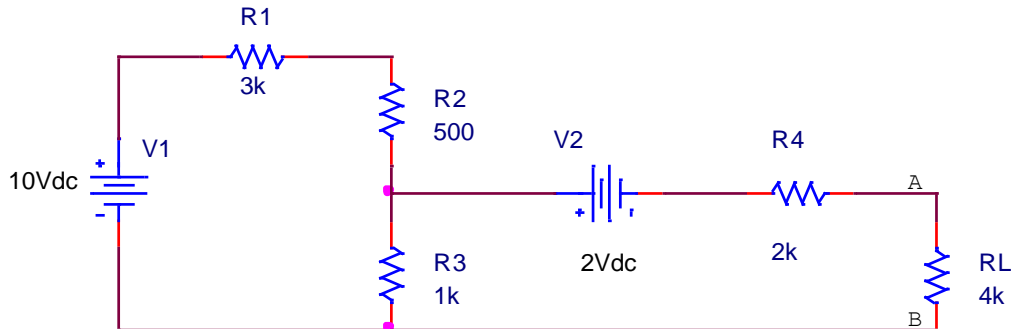

1.a) (5 pnts) Find the Thevenin voltage between points A and B:

Need open circuit voltage across AB, so voltage divider to find voltage across R3:

$$V_{R3} = V1 * (R3 / (R1 + R2 + R3)) = 2.222V,$$

then subtract V2 to get 0.222V,

No voltage drop across R4 as open circuit, so **Vth = 0.222 V**

1.b) (5 pnts) Find the Thevenin resistance between points A and B:

To find Rth, sources are considered shorts. This leaves the series combination of R1 and R2 in parallel with R3:

$$R[(1+2) || 3] = (R1 + R2) * R3 / (R1 + R2 + R3) = 0.778 \Omega$$

This resistance is in series with R4 (again, V2 is a short):

$$\mathbf{Rth = R[(1+2) || 3] + R4 = 2.78 \Omega}$$

1.c) (3 pnts) Draw the Thevenin equivalent of the circuit shown, showing  $R_L$  in the equivalent circuit:

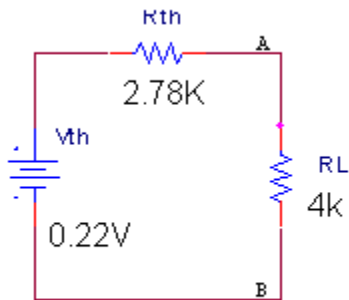

1.d) (3 pnts) What is the voltage across A-B with the load resistor included?

Use voltage divider:

$$V_{AB} = V_{th} \frac{R_L}{R_{th} + R_L} = 0.222 \text{ V} \frac{4 \text{ k}\Omega}{4 \text{ k}\Omega + 2.78 \text{ k}\Omega} = 131 \text{ mV}$$

1.d) (2 pnts) If the source  $V_1$  was broken into two 5V series sources, qualitatively, how would the Thevenin voltage change?

The Thevenin voltage would not change – the voltage produced by the two sources would be the same as the original.

1.e) (2 pnts) Why do we use the Thevenin equivalent voltages and resistances? Give two reasons.

- (1) It allows for simpler analysis of the circuit when the load resistor changes – instead of having to re-calculate everything over and over again.
- (2) Complex and unknown circuits may be measured and represented as the Thevenin circuits without known the full schematic.

### Question Set 2) More Thevenin with Op Amps (20 pnts)

You built the circuit pictured below. All of the resistor and source values are unknown! Although it is known that all of the resistors are less than 10 k $\Omega$ .  
(Why did you do this?!?)

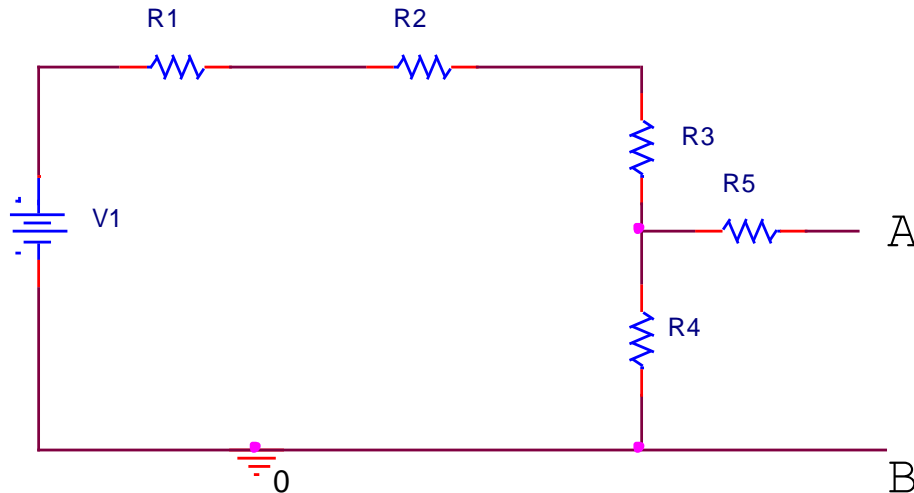

Several voltage measurements were made across AB ( $V_{AB}$ ) with difference load resistor values:

	Test 1	Test 2	Test 3
$R_{AB}$ (load)	1 k $\Omega$	10 M $\Omega$	10 k $\Omega$
$V_{AB}$	497.5 mV	1.707 V	1.373 V

2.a) (4 pnts) Find the Thevenin Equivalent voltage,  $V_{th}$ , of this circuit between point A and B.

May be done in 2 ways. Easy: knowing Test 2 uses a very large resistor compared to the rest, this is essentially the open source voltage, a measurement of the Thevenin voltage:  $V_{th} = 1.707$  V

Hard: use two versions of voltage divider equations and solve for  $V_{th}$  (solution not shown):

$$V_{AB}(R_{AB}) = V_{th} \frac{R_{AB}}{R_{th} + R_{AB}}$$

2.b) (4 pnts) Find the Thevenin Equivalent resistance,  $R_{th}$ , of this circuit between point A and B.

Pick either Test 1 or Test 3 to use here as the load resistance is in the range of the resistors used to build it (estimated). Solve the Thevenin voltage divider equation for  $R_{th}$  (test 1 used here):

$$V_{AB}(R_{AB}) = V_{th} \frac{R_{AB}}{R_{th} + R_{AB}} \rightarrow 0.4975 \text{ V} = 1.707 \text{ V} \frac{1 \text{ k}\Omega}{R_{th} + 1 \text{ k}\Omega}$$

$$R_{th} = 2.43 \text{ k}\Omega$$

Also could have been found from Hard solution in 2.a.

2.c) (1 pnt) Redraw the Thevenin equivalent model for the circuit.

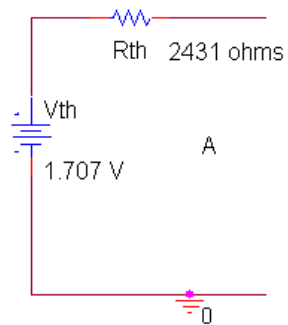

2.d) (3 pnts) If a 2 kΩ resistor is used as a load, what will the load voltage and current be?

$$V_{AB} = V_{th} \frac{R_{AB}}{R_{th} + R_{AB}} \rightarrow V_{AB} = 1.707 \text{ V} \frac{2 \text{ k}\Omega}{2.43 + 2 \text{ k}\Omega} \rightarrow V_{AB} = 0.770 \text{ V}$$

$$V_{AB} = I_{AB} R_{AB} \rightarrow I_{AB} = \frac{V_{AB}}{R_{AB}} \rightarrow I_{AB} = \frac{0.770 \text{ V}}{2 \text{ k}\Omega} = 0.385 \text{ mA}$$

2.e) (3 pnts) An operational amplifier circuit is added to the circuit as shown below.

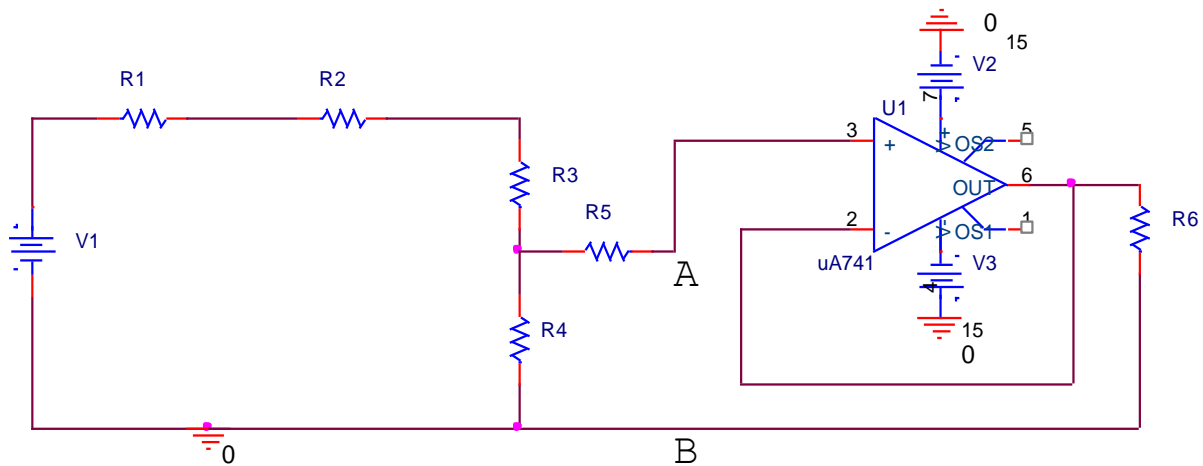

What type of operational amplifier circuit was added and how is it useful in this case?

**Voltage Follower.** The voltage follower isolates the circuit we modeled from the load R6. This means that whatever voltage the circuit puts out between A and B will be transferred to R6 without being influenced by the value of R6.

2.f) (2 pnts) What is the voltage output between A and B for the circuit shown in 2.e?

The voltage between A and B will always be the Thevenin voltage for the circuit because the buffer looks like an infinite impedance to it. Since an infinite impedance is much much bigger than  $R_{th}$ , it will not influence the circuit. Therefore:

$$V_{AB} = V_{th} = 1.707 \text{ V}$$

2.g) (2 pnt) What is the current through resistor R5?

Current into V+ of amplifier (pin 3) is always 0. Therefore  $I_{R5} = 0 \text{ A}$

2.h) (1 pnt) What is the current through resistor R6?

Voltage out of opamp is the same as  $V_{AB}$ . Therefore:

$$I_6 = \frac{V_{AB}}{R_6} = \frac{1.707 \text{ V}}{2 \text{ k}\Omega} = 0.854 \text{ mA}$$

### Question Set 3) Operational Amplifiers (20 pnts)

Answer questions 3.a-3.e considering the circuit below. Assume that the voltage at point **A** is represented as:  $V_A = A\cos(\omega t + \phi)$ . Further assume that  $V_+$  for each op amp is connected to +5 V and  $V_-$  is connected to -5 V.

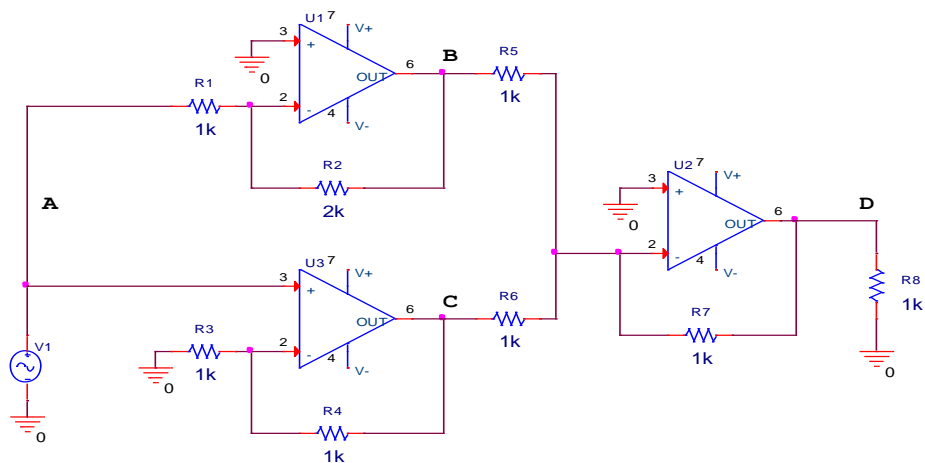

3.a) (3 pnts) What is the voltage at point **B**,  $V_B$ , ideally?

U1 is an inverting amplifier, therefore:

$$V_B = -\frac{R_2}{R_1}V_A = -\frac{2k}{1k}A\cos(\omega t + \phi) = -2A\cos(\omega t + \phi)$$

3.b) (3 pnts) What is the voltage at point **C**,  $V_C$ , ideally?

U2 is a non-inverting amplifier, therefore:

$$V_C = \left(1 + \frac{R_4}{R_3}\right)V_A = \left(1 + \frac{1k}{1k}\right)A\cos(\omega t + \phi) = 2A\cos(\omega t + \phi)$$

3.c) (3 pnts) What is the voltage at point **D**,  $V_D$ , ideally?

U3 is an adder, therefore:

$$V_D = -\frac{R_7}{R_5}V_B - \frac{R_7}{R_6}V_C = -\frac{1k}{1k}(-2A\cos(\omega t + \phi)) - \frac{1k}{1k}(2A\cos(\omega t + \phi))$$

$$V_D = 0 \text{ V}$$

3.d) (6 pnts) On the grid below, plot  $V_B$ ,  $V_C$ , and  $V_D$  assuming that the V- connection to the op amps has been changed to  $-4\text{ V}$ . Use these values for the constants:  $A = 2.5\text{ V}$ ,  $\phi = 0^\circ$ ,  $\omega = 1\text{ rad s}^{-1}$ . Ensure to label the y-axis and each curve.

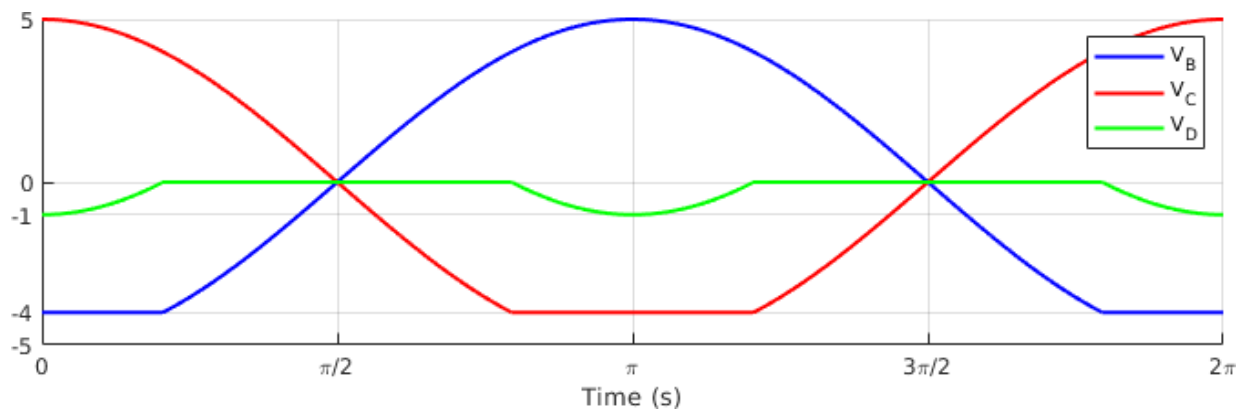

3.e) (2 pnts) An unknown op amp circuit is being analyzed and through measurements of the input and output, it was shown that the output signal's phase is shifted  $+90^\circ$  compared to the input signal's phase. What type of op amp circuit is it (assuming it is one that you have learned of in class)?

**Integrator (either type is fine).**

Differentiator imparts a phase shift of  $-90^\circ$ ...

Differentiation gives  $90^\circ$ , circuit inverts as well ( $\pm 180^\circ$  phase shift), for a resultant shift of  $-90^\circ$

Integration gives  $-90^\circ$ , circuit inverts as well ( $\pm 180^\circ$  phase shift), for a resultant shift of  $90^\circ$

3.f) (2 pnts) A differentiator will turn an input square wave into a triangular wave at its output.

**TRUE or FALSE**     **FALSE:** It is the other way around. Triangular wave to square

3.g) (1 pnt)  $V_+$  (supply) is connected to pin 8 of the op amp IC that we use in the lab.

**TRUE or FALSE**     **FALSE:** Nothing gets connected to pin 8.  $V_+$  goes to pin 7.



### Question Set 4) Damped Sinusoids and Miscellaneous (20 pnts)

You are given a cantilever beam similar to the one you used in experiment 4. You place two weights on the end of the beam (0.1 kg and 0.5 kg) and you get the following two plots.

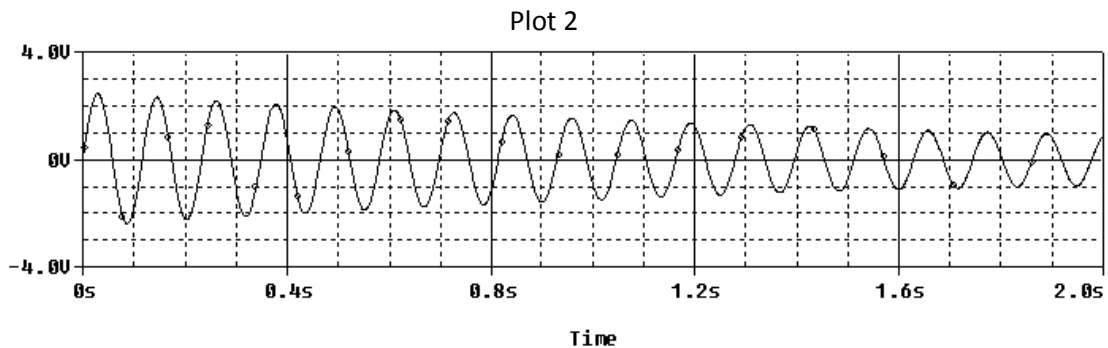
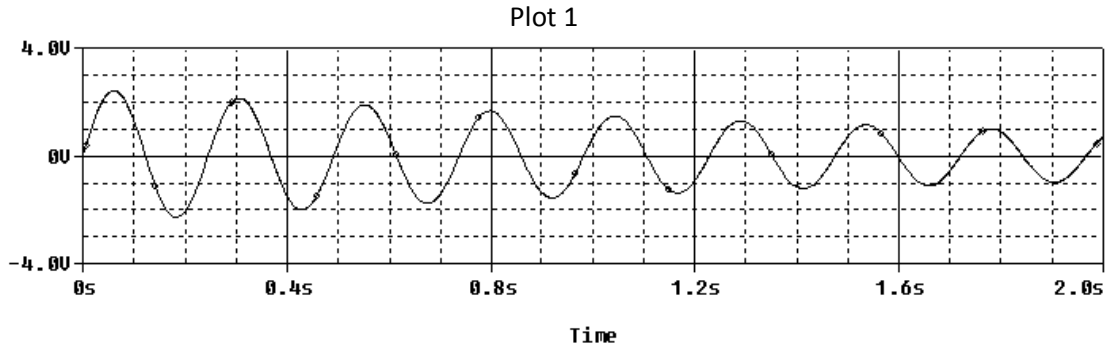

4.a) (2 pnts) What is the frequency of **plot 1**? (Accurate to at least 2 significant figures)

$$f_1 = 8 \text{ cycles} / 1.97\text{s} = 4.1 \text{ Hz}$$

To get fill credit: answer must be done by considering points far apart, otherwise It is an inherently inaccurate answer (even if by chance the answer was close to correct)

4.b) (2 pnts) What is the frequency of **plot 2**? (Accurate to at least 2 significant figures)

$$f_2 = 17 \text{ cycles} / 1.98\text{s} = 8.6 \text{ Hz}$$

To get fill credit: answer must be done by considering points far apart, otherwise It is an inherently inaccurate answer (even if by chance the answer was close to correct)

4.c) (3 pnts) What is the damping constant for **plot 1**? (Accurate to at least 2 significant figures)

Points used:  $(t_0, v_0) = (0.07, 2.4)$   $(t_1, v_1) = (1.78, 1.0)$

$$v_1 = v_0 e^{-\alpha(t_1 - t_0)} \rightarrow 1.0 = 2.4 e^{-\alpha(1.78 - 0.07)} \rightarrow 0.875 = 1.71 \alpha \rightarrow \alpha = 0.5/\text{s}$$

To get fill credit: answer must be done by considering points far apart, otherwise It is an inherently inaccurate answer (even if by chance the answer was close to correct)

4.d) (3 pnts) Given the following formula,  $k = (m + m_n)(2\pi f)^2$ , and assuming that the two data points that you found are ideal, find values for  $k$  and  $m$ .

$$k = (m + 0.1 \text{ kg})(2\pi(8.6 \text{ Hz}))^2$$

$$k = (m + 0.5 \text{ kg})(2\pi(4.1 \text{ Hz}))^2$$

$$k = (2920 \text{ s}^{-2})m + 292 \text{ kg s}^{-2}$$

$$k = (663.6 \text{ s}^{-2})m + 331.8 \text{ kg s}^{-2}$$

$$(2920 \text{ s}^{-2})m + 292 \text{ kg s}^{-2} = (663.6 \text{ s}^{-2})m + 331.8 \text{ kg s}^{-2}$$

$$m = 0.017 \text{ kg}$$

$$k = (2920 \text{ s}^{-2})(0.017 \text{ kg}) + 292 \text{ kg s}^{-2} \rightarrow k = 343 \text{ kg s}^{-2}$$

4.e) (2 pnts) What is the mass of the beam?

$$m = 0.23 m_{beam} \rightarrow (0.017 \text{ kg}) = 0.23 m_{beam}$$

$$m_{beam} = 0.074 \text{ kg} = 74 \text{ g}$$

4.f) (3 pnts) Using the chart for Young's Modulus below, determine the probable material that the beam is made out of given that the dimensions of the beam are: 1.5 cm wide, 20 cm long, 2 mm thick.

TABLE 9.1			
Young's Modulus Table of Values			
Metal	Elastic modulus (N/m <sup>2</sup> )	Metal	Elastic modulus (N/m <sup>2</sup> )
aluminum, 99.3%, rolled	$6.96 \times 10^{10}$	lead, rolled	$1.57 \times 10^{10}$
brass	$9.02 \times 10^{10}$	platinum, pure, drawn	$16.7 \times 10^{10}$
copper, wire, hard drawn	$11.6 \times 10^{10}$	silver, hard drawn	$7.75 \times 10^{10}$
gold, pure, hard drawn	$7.85 \times 10^{10}$	steel, 0.38% C, annealed	$20.0 \times 10^{10}$
iron, wrought	$19.3 \times 10^{10}$	tungsten, drawn	$35.5 \times 10^{10}$

$$k = \frac{Ewt^3}{4l^3} \rightarrow 343 \text{ kg s}^{-2} = E \frac{(0.015 \text{ m})(0.002^3 \text{ m}^3)}{4(0.2^2 \text{ m}^2)}$$

$$E = 92 \text{ GPa} \rightarrow \text{Probably Brass}$$

4.g) (2 pnts) What's the difference between an ideal integrator and a Miller Integrator? And what is the purpose of this difference?

Miller Integrators have a resistor in parallel with the capacitor on the feedback path. This is used to ensure that DC offsets and low frequency signals do not cause the integrator to go unstable (and saturate) when the capacitor is acting like an open circuit.

4.h) (1 pnt) Why do we use a bridge circuit with the strain gauges?

Bridges allow the measurement to be differential rather than absolute. For example, a change of 2.500 to 2.502 may be insignificant in an absolute measurement. A differential change from 0 to 0.002 is much more significant a change

4.i) (1 pnt) What does the 'K' stand for in KCL and KVL?

Kirchoff

4.j) (1 pnt) What is the name of the professor speaking on the course videos?

Prof. Ray Smith	Mr. Dr. Prof. Patrick Star	Prof. Ken Connor
Prof. James Moriarty	Prof. Jeff Braunstein	Prof. John Wen
Prof. Ken Vastola	Prof. Don Millard	Prof. Charles Xavier