

ENGR-2300
Electronic Instrumentation
Quiz 1
Fall 2014

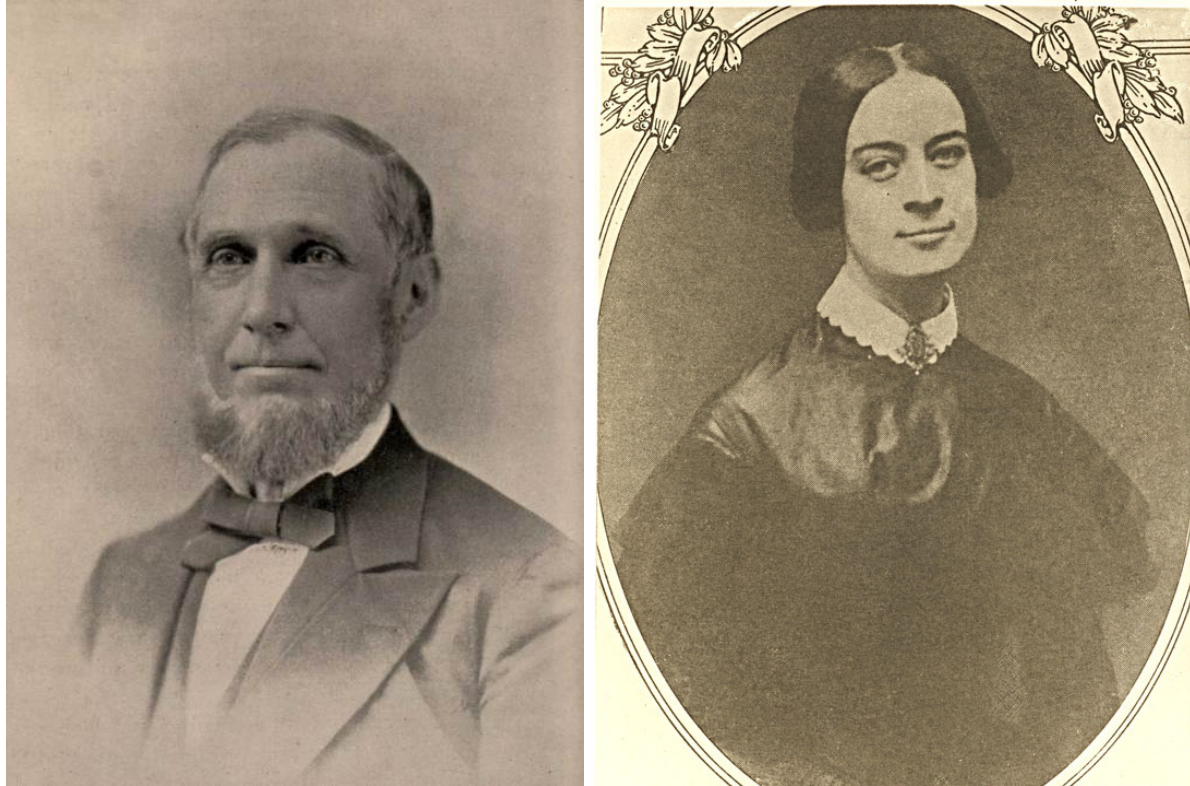

On all questions: **SHOW ALL WORK. BEGIN WITH FORMULAS, THEN SUBSTITUTE VALUES AND UNITS.** No credit will be given for numbers that appear without justification. Read the entire quiz before answering any questions. Also it may be easier to answer parts of questions out of order.



BLACK FRIDAY, 24 SEPTEMBER 1869 – Russell Sage

There's a "Money King" in every generation. Ruthless, conniving, thieving... Russell Sage was one of the biggest Wall Street operators during the Gilded Age, and he managed to play such names as Vanderbilt and Gould against one another.

Jay Gould became infamous for his unsuccessful effort to corner the public supply of gold in 1869. To do so, he needed to prevent President Ulysses S. Grant from releasing gold from the federal stockpile, which he hoped to achieve by bringing the President's brother-in-law into the scheme. Gould managed to put on such a good show that many investors bid up the price of gold.

As soon as Grant learned what was happening, however, he released large stocks of federal gold for sale, which caused the price to return to normal. Unfortunately, many speculators purchased gold on margin and were ruined when the price collapsed. This had a cascading effect, as many investors sold stock in order to cover losses on gold, which triggered more margin calls and further selling.

BLACK FRIDAY, 1869

The result was Black Friday, September 24, 1869, when the stock market crashed. Gould reaped a fortune despite the collapse of his plot. He of course knew before anyone else that his efforts were fruitless. Before news got out, he sold gold as well as other assets short, using Russell Sage

as his agent. Sage also worked with Gould to manipulate the stock of the Union Pacific Railroad, of which Sage was a member of the board of directors.

PRESERVING MEMORY

Russell Sage died in 1906, worth an estimated \$70-100 million. He left his fortune to his wife, Margaret Olivia Slocum Sage, who devoted the rest of her life to preserving the memory of her husband by creating a number of charitable organizations in his name. She founded the **Russell Sage Foundation** in 1907 (with an initial gift of \$10M) to support initiatives to help the poor. She also became active in the women's suffrage movement, but began to believe that the right to vote was less important for many women than the ability to earn an independent living. With that in mind, she founded **Russell Sage College** in upstate New York to give women from lower-income families the opportunity to learn a profession.

Olivia was a woman of her times and she named many of her gifts after her husband and the other men in her family, including RPI's **Russell Sage Laboratory** building (after her husband) and **Russell Sage 2nd Dining Hall** (after Sage's nephew, RPI Class of 1859). Sage Lab was the first home of Electrical and Mechanical Engineering at RPI. Many believe that her motive in these regards, including her many gifts to prestigious universities (regardless of their attitude toward accepting and educating women) was her attempt to salvage Russell's less than stellar reputation.

References:

<http://premium.working-money.com/wm/display.asp?art=430>

<http://www.womensfundofcny.org/history-women-philanthropy/margaret-olivia-slocum-sage>

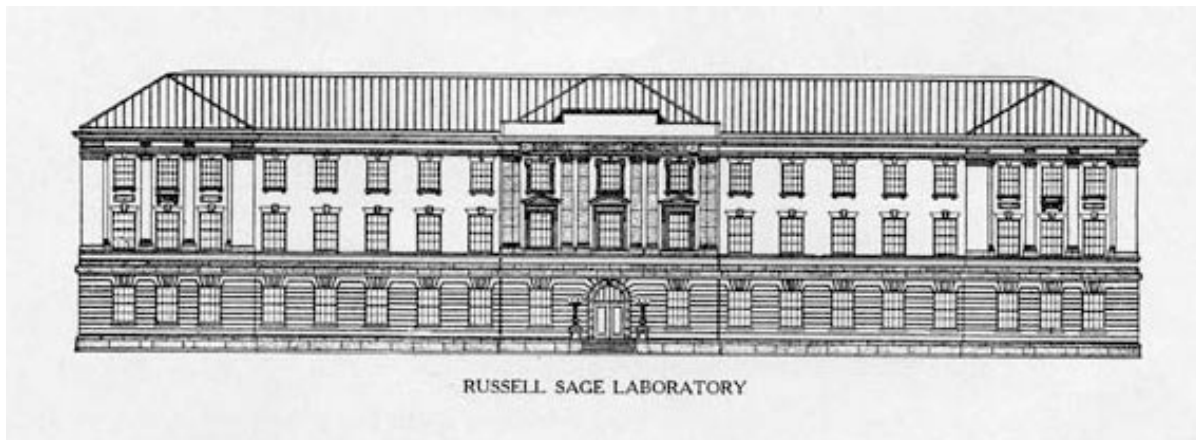

Analog Discovery Connections

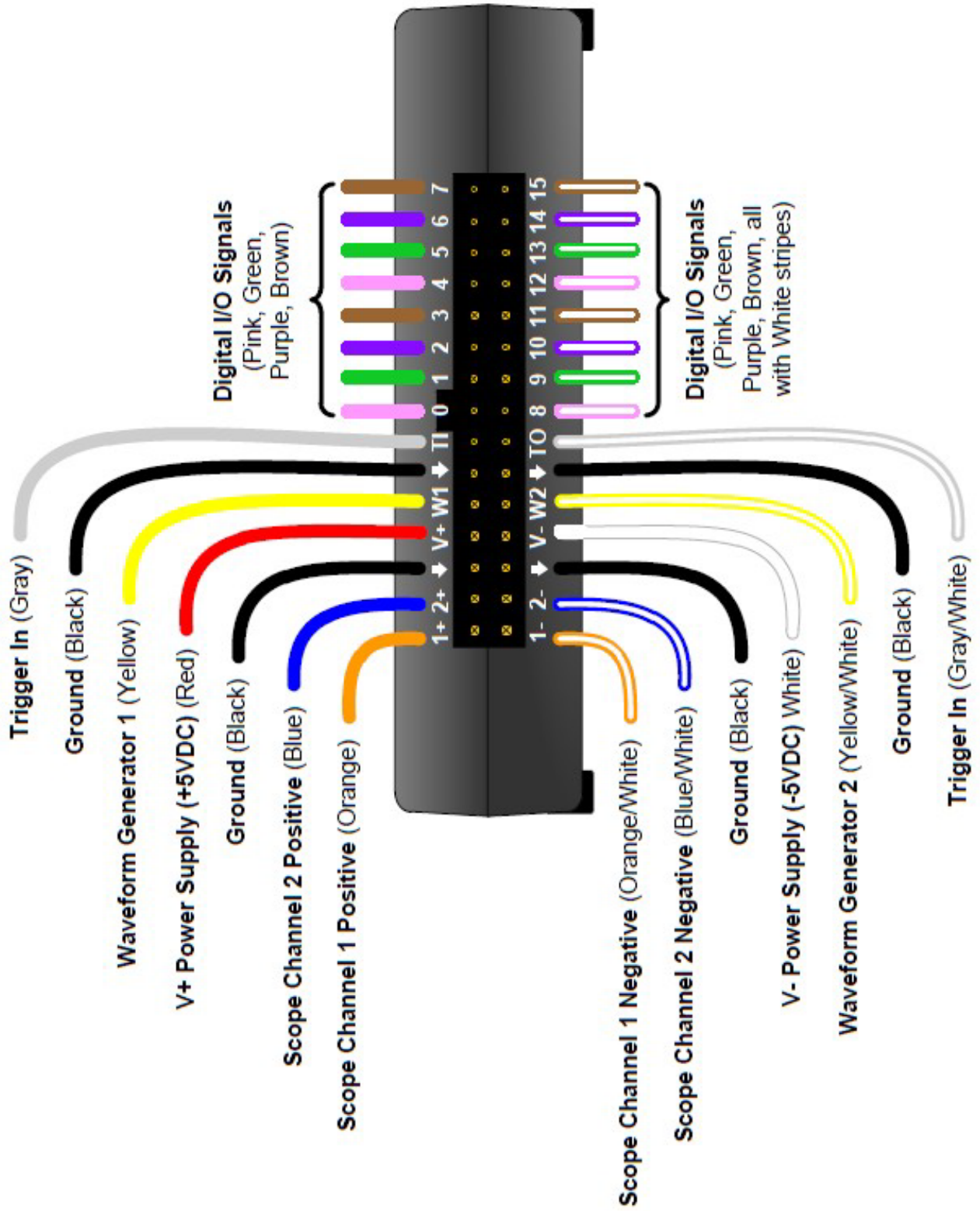

I. Voltage Dividers (25 points)

- a) Find the voltage
- V_{out}
- in the circuit below. (3 pts)

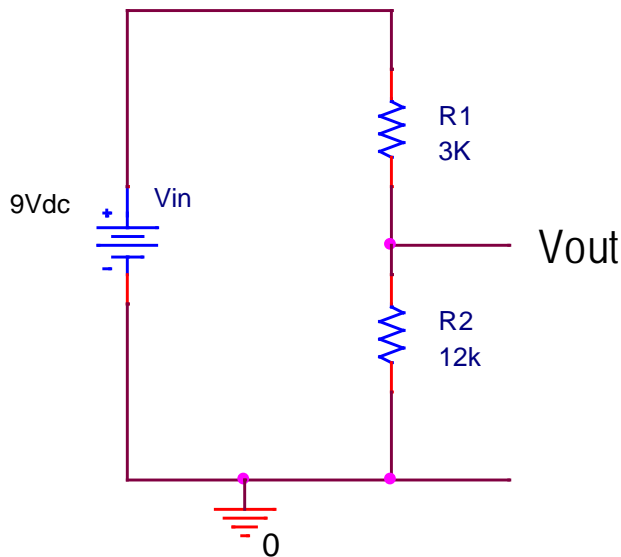

$$V_{out} = \frac{12}{12+3}9 = \frac{36}{5} = 7.2V$$

- b) Find the current
- I
- in resistor R1. (3 pts)

$$I = 9/15mA = 0.6mA$$

- c) The following circuit is used to determine the internal resistance of a AAA battery. For
- $R_{load} = 1M\Omega$
- ,
- $V_{out} = 1.6V$
- . For
- $R_{Load} = 10\Omega$
- ,
- $V_{out} = 1.5V$
- . What is the battery voltage
- V_{batt}
- and what is its internal resistance
- R_{batt}
- ? (4 pts)

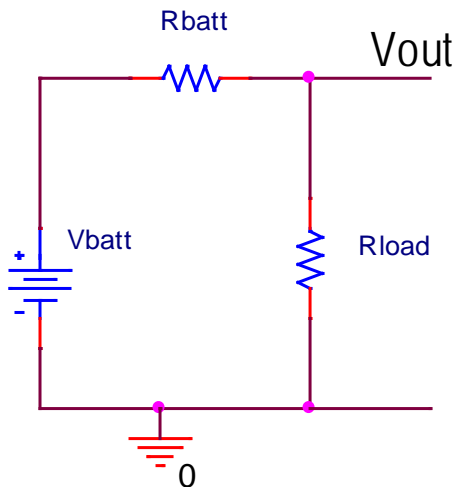

$$V_{batt} = 1.6V$$

$$V_{out} = \frac{10}{10 + R_{batt}}1.6 = 1.5$$

$$R_{batt} = 0.67\Omega$$

- d) Find the power delivered to
- $R_{load} = 10\Omega$
- . Will a
- $\frac{1}{4}$
- Watt resistor be adequate for this measurement or will a
- $\frac{1}{2}$
- Watt or 1 Watt resistor be required? (4 pts)

$$P = \frac{1.5^2}{10} = 225mW \text{ which is less than } \frac{1}{4} \text{ Watt, so the } \frac{1}{4} \text{ Watt resistor is fine.}$$

- e) In Experiment 5, we will use a circuit configuration called a Wheatstone Bridge, which consists of two identical voltage dividers, with $R_1 = R_2 = R_3 = R_4 = R$. Assume that we

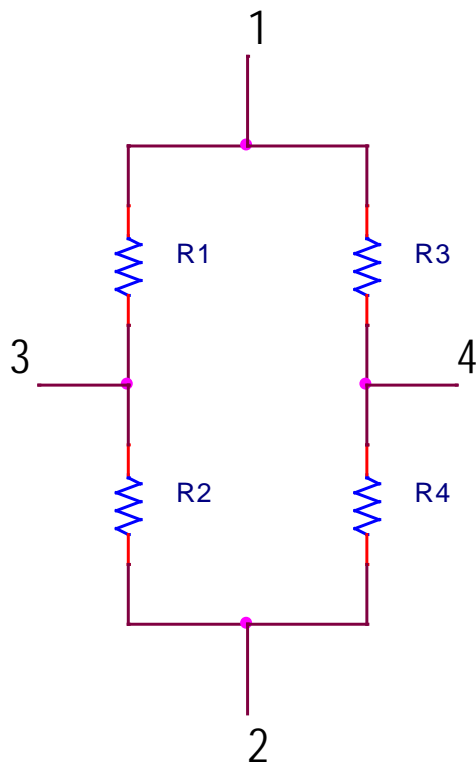

have such a bridge but we do not know the value R of the resistors, so the following resistance measurements are made across each pair of adjacent terminals: $R_{14} = 90\Omega$, $R_{42} = 90\Omega$, $R_{23} = 90\Omega$, $R_{31} = 90\Omega$. Use the measured values to determine the resistance of R . (4 pts)

$$R_{14} = 90 = \frac{R(3R)}{R + 3R} = \frac{3R}{4}$$

$$R = 120\text{Ohms}$$

- f) Now that you know the value of R , what resistance would be measured across opposite terminals? That is, what do R_{12} and R_{34} equal? (2 pts)

Both equal R because the combination is $2R//2R=R$

- g) In the bridge circuit of Experiment 5, the two resistors in the left divider are fixed while the resistors in the right divider are strain gauges. One strain gauge is mounted on the top of a cantilever beam while the other is on the bottom. When the beam is deflected up or down, the resistance of one gauge increases by a few Ohms while the other decreases by an identical amount. Thus, $R_1 = R_2 = R$ and $R_3 = R + \Delta R$, $R_4 = R - \Delta R$. Assume a 12V battery is connected across terminals 1 and 2 (+12V at terminal 1 and ground at terminal 2) and that R is the value you found in the previous question. Determine the voltages at terminals 3 and 4 (V_3 and V_4) and find the difference between the two voltages ($V_3 - V_4$) in terms of ΔR . (5 pts)

$$V_{out} = V_3 - V_4 = \frac{12}{2} - \frac{R - \Delta R}{R + \Delta R + R - \Delta R} 12 = \frac{\Delta R}{R} 6 = \frac{\Delta R}{20}$$

Negative sign error, only 1pt deducted.

II. Filters & Transfer Functions (25 points)

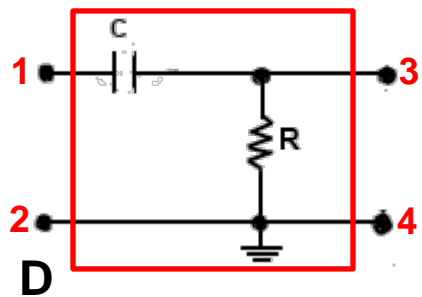
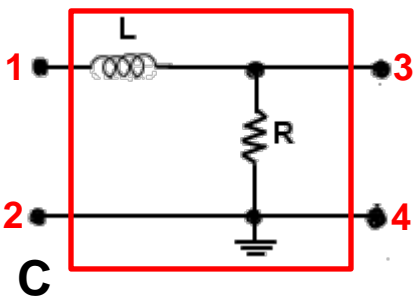
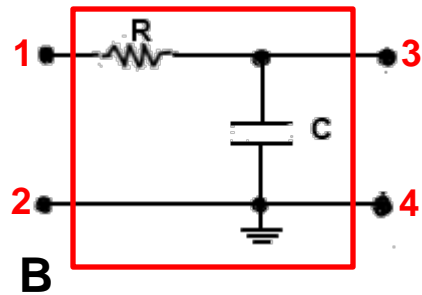
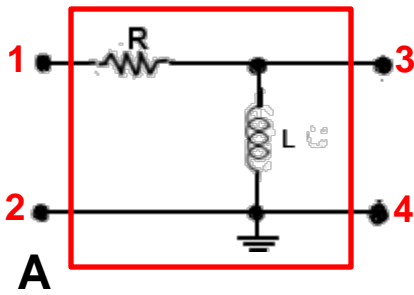

a) Shown above are the four basic, two-element, passive filter configurations made with RL or RC combinations. Assume the four circuits are enclosed in unmarked, black boxes, like the one shown at the left. That is, we know that the four boxes each contain one of the circuits and decide to make a series of measurements to identify them making various connections with the two inputs and two outputs. We think we can identify which is which by making the DC resistance measurements listed in the table below. *Hint: The R, L & C are realistic circuit components and, thus, are not necessarily represented by just their ideal circuit elements.* (8 pts)

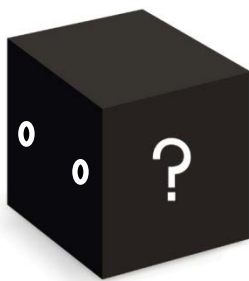

R_{12}	R_{13}	R_{34}	R_{24}	Circuit	R_{12} SC Load
∞	$1k\Omega$	∞	0	B	$1k\Omega$
$1.1k\Omega$	100Ω	$1k\Omega$	0	C	100Ω
$1.1k\Omega$	$1k\Omega$	100Ω	0	A	$1k\Omega$
∞	∞	$1k\Omega$	0	D	∞

Explanation: *At DC: L has resistance of 100Ohms; C is infinite; R is 1kOhms*

b) What input resistance R_{12} would be measured in each case when the load is a short circuit (SC)? Add your answer to the table. (4 pts)

See Table Above.

- c) A function generator is connected to the input of each circuit and the output voltage is measured as a function of frequency. If the input voltage has an amplitude of 1V, identify which of the curves plotted below is the output for each of the four circuits. Label them A, B, C, D, respectively. (4 pts)

Use the voltage divider info at DC to ID the plots.

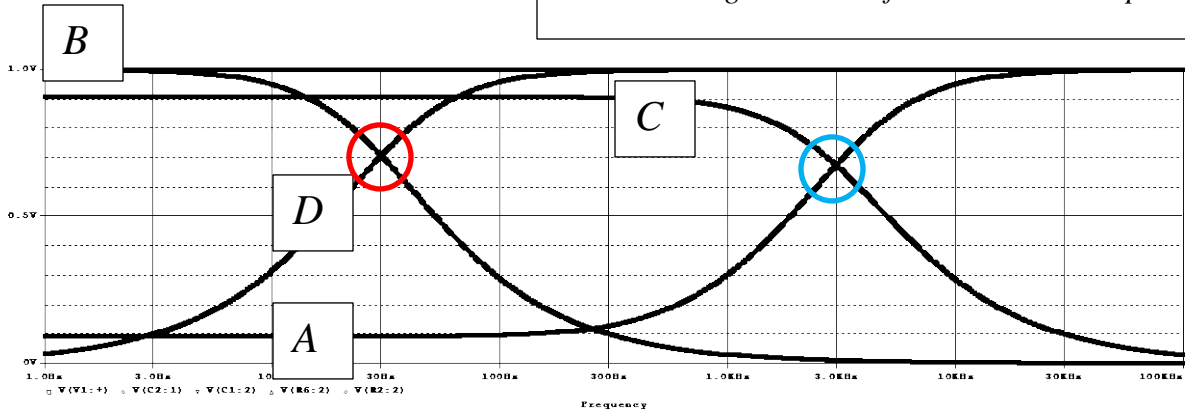

- d) From the information in the plots, determine the values of the inductance L and the capacitance C for the four circuits. (4 pts)

The RC corner frequency is 30Hz (where B and D cross – circled in Red) while the RL corner frequency is 3kHz (where A and C cross – circled in Blue).

$$C = \frac{1}{2\pi f R} = \frac{1}{60\pi \cdot 1000} = 5.3\mu F \quad L = \frac{R}{2\pi f} = \frac{1000}{6000\pi} = 53mH$$

- e) Find the transfer function for the circuit below. Then simplify the expression for low and high frequencies. What kind of a filter is this circuit? Low Pass, High Pass, Band Pass or Band Reject? (5 pts)

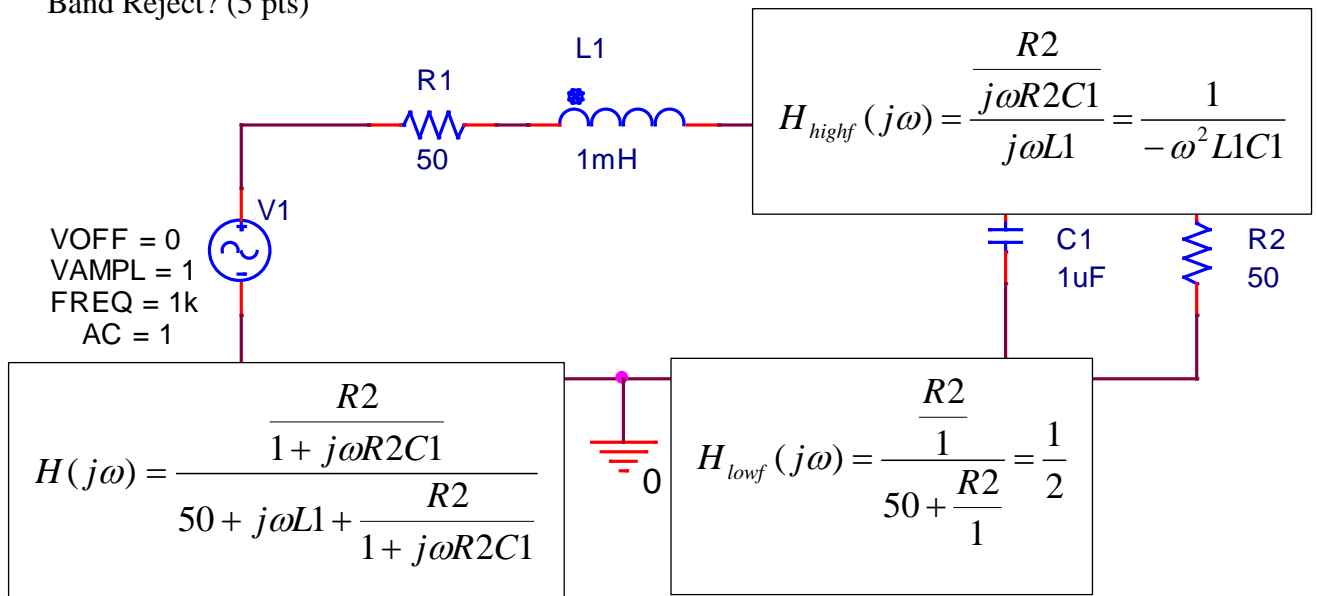

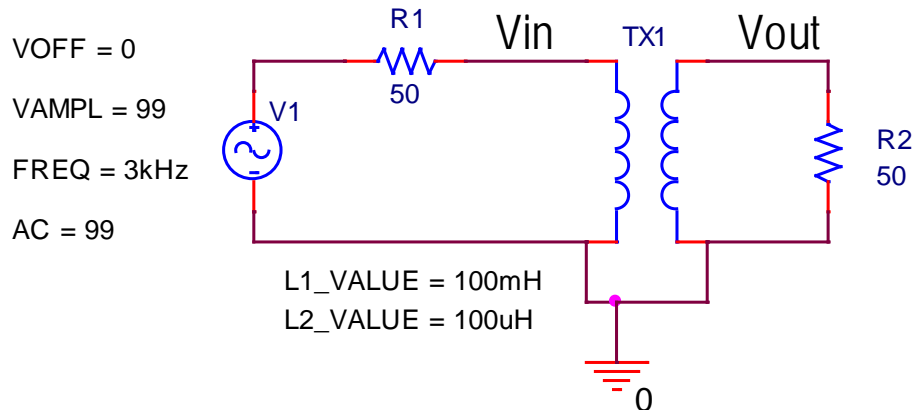
III – Signals, Transformers and Inductors (25 points)

Given the circuit above, assume an ideal transformer with full coupling. In your answers to the following questions, use all available information

- a) For the given information, write out the expressions for the ratios V_{out}/V_{in} , I_{out}/I_{in} and the transformer input impedance R_{in} . (9 pts)

$$\frac{V_{out}}{V_{in}} = a = \sqrt{\frac{L_2}{L_1}} = \sqrt{0.001} = 0.0316 \quad \frac{1}{a} = 31.6 \quad \frac{I_{out}}{I_{in}} = \frac{1}{a} = 31.6$$

$$Z_{in} = \frac{50}{a^2} = 50k$$

- b) Find V_{in} using voltage divider circuit consisting of the transformer input impedance R_{in} and the resistance $R1$ (4 pts)

$$Z_{in} \gg R1, \text{ so } V_{in} = VI$$

(Check the voltage divider relationship, if you do not immediately see this.)

- c) Find V_{out} from your value for V_{in} . (4 pts)

$$V_{out} = 0.0316V_{in} = 0.0316(99) = 3.13 \text{ Volts}$$

- d) Determine both the primary and secondary currents (I_1 and I_2). (4 pts)

$$I_2 = 3.13/50 = 6.26 \text{ mA} \quad I_1 = 62.6/31.6 = 1.98 \text{ mA}$$

- e) Determine the power from the source V_1 and the power delivered to the load R_2 . Compare the results. (4 pts)

$$P_{source} = 1.98 \text{ mA } 99 \text{ V} = 196.1 \text{ mW}$$

$$P_{load} = (3.13)(62.6) = 195.9 \text{ mW}$$

Which leaves .2mW in R_1 and justifies ignoring it.

IV – Instrumentation, PSpice, Components, Troubleshooting & Concepts (25 points)

For most of the experiments and simulations we do in this course, the circuit configuration can be shown generically as:

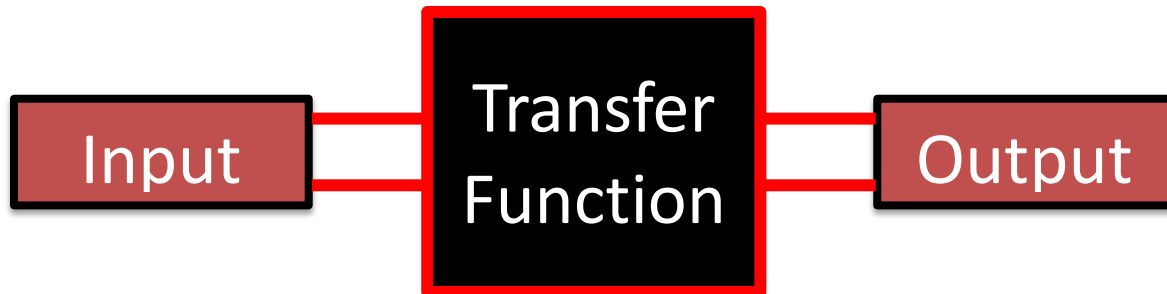

- a) In EI, we make essentially all measurements using an Analog Discovery board, which provides the functionality of an oscilloscope, function generator, DC power supply ... Each of these functions requires making two connections to a circuit. On Analog Discovery, every connection is a wire with a particular color or combination of colors and a name (e.g. orange and 1+). On the diagrams below, label both the color and name of the two wires used for each function. (4 pts)

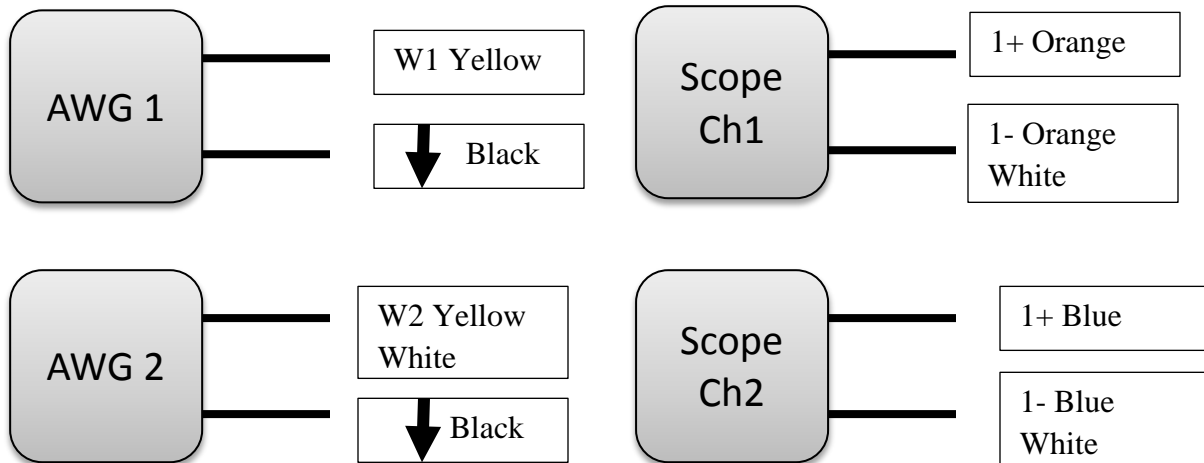

- b) What are the three color stripes found on a 1k Ω resistor (in order)? (3 pts)

Brown, Black, Red

- c) The hand-drawn figure below shows a simple voltage divider circuit. The Analog Discovery ground symbol has been placed on the figure to show where the black wire should be connected. Place the following symbols (W1, 1+, 1-, 2+, 2-) at the locations where the corresponding wires should be connected to provide the input signal and to measure both the input and output voltages. (5 pts)

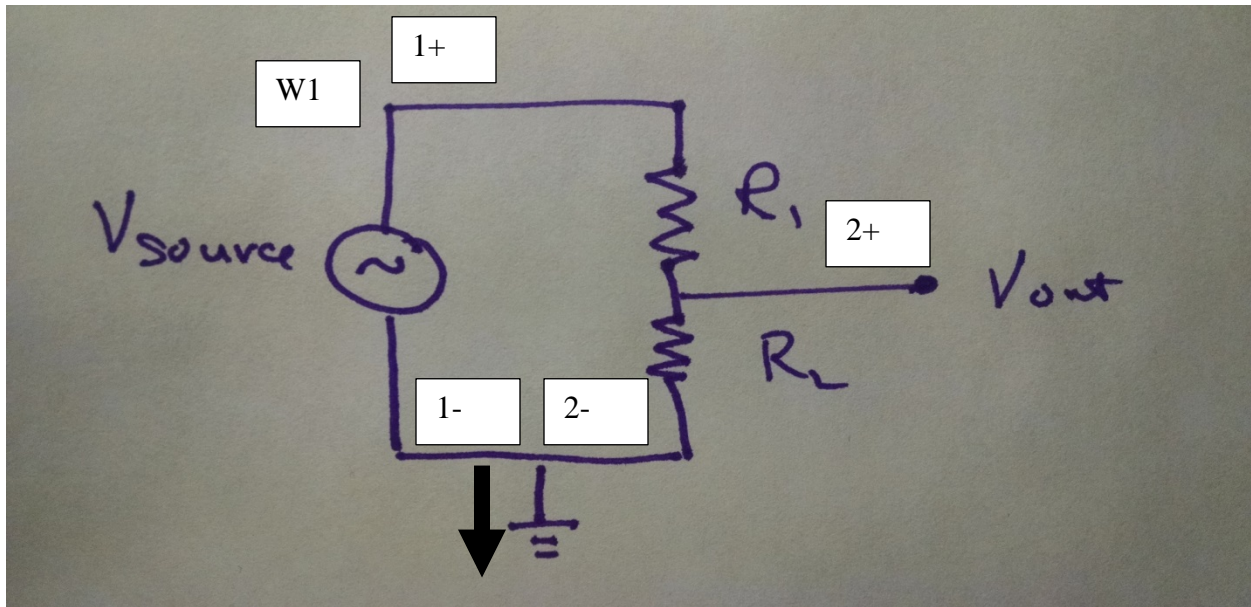

- d) Part of a spec sheet for an inductor is reproduced below. Using the information provided, draw and label a practical circuit model of this inductor. (5 pts)

Brand:	Bourns
Inductance:	33 mH L
Maximum DC Current:	20 mA
Maximum DC Resistance:	140 Ohms R
Operating Temperature Range:	+ 40 C to + 105 C
Self Resonant Frequency:	0.16 MHz

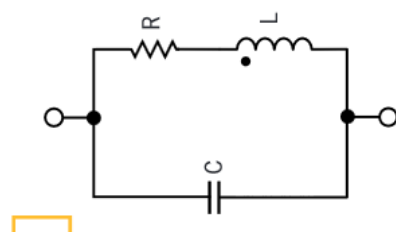

$$C = 1 / ((2\pi f)^2 L)$$

$$= 30 \text{ pF}$$

2 pts each for R & L.
1 pt for C.

- e) The figure below shows two signals displayed by the Analog Discovery scope channels. The top signal is the voltage observed across a small, commercial DC electric motor. The bottom signal is the voltage produced by a solar cell detecting the light from a green laser pointer. The four pulses occur when a small tab on a wheel driven by the motor blocks the laser light, once per revolution. If the horizontal scale goes from -25ms to +25ms (5ms/div), what is the approximate frequency of each signal? (4 pts)

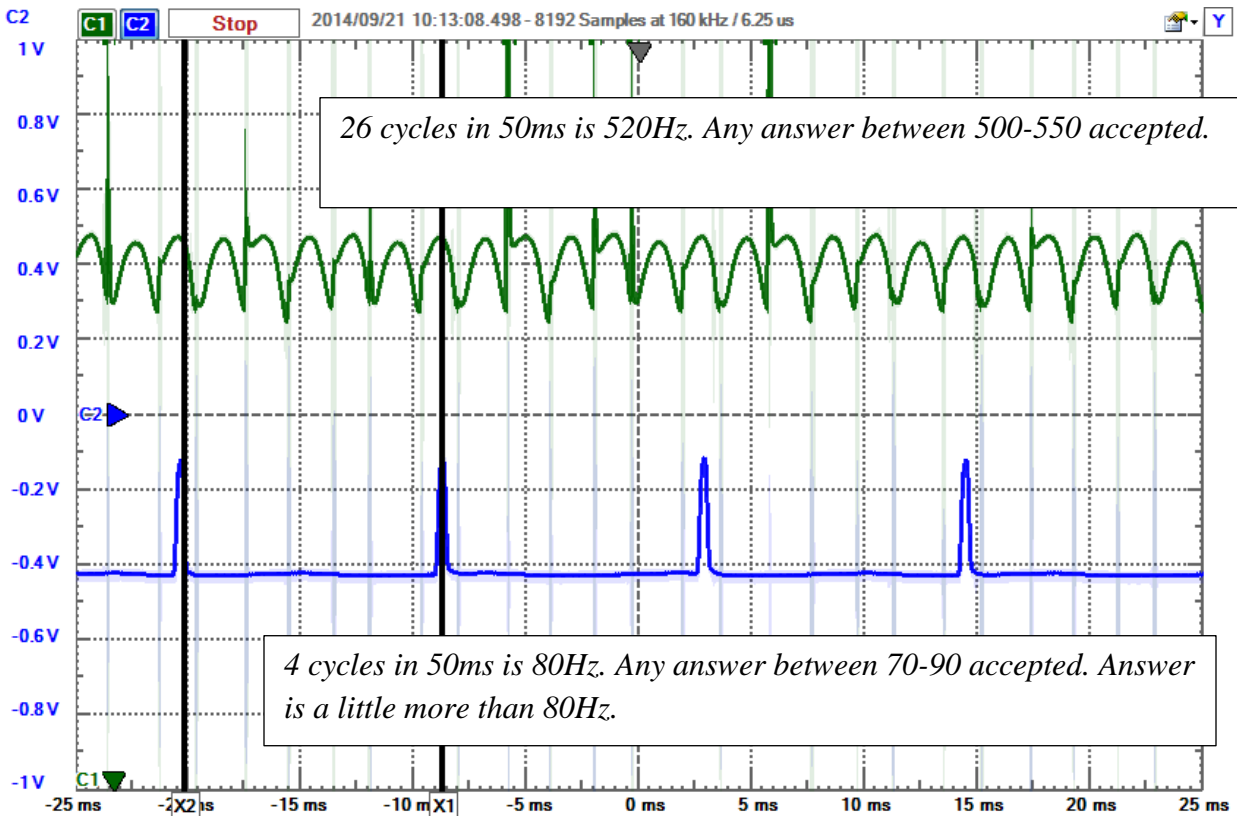

- f) What building was the original home of both Electrical and Mechanical Engineering at RPI? What is the approximate width of the front wall (with the window and main door) in the LITEC room, where EI meets? (4 pts)

Sage Lab Building and 20 ft. Any reasonable answer accepted.