

# Quiz 2 Solutions

I. a.)

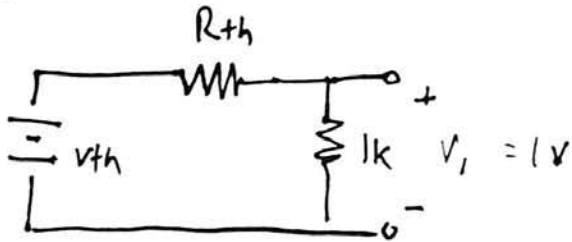

Using voltage division,

$$V_1 = 1 = V_{th} \left( \frac{1k}{1k + R_{th}} \right)$$

$$V_{th} \cdot 1k = R_{th} + 1k$$

$$V_{th} = \frac{R_{th}}{1k} + 1 \implies \text{Eqn. 1}$$

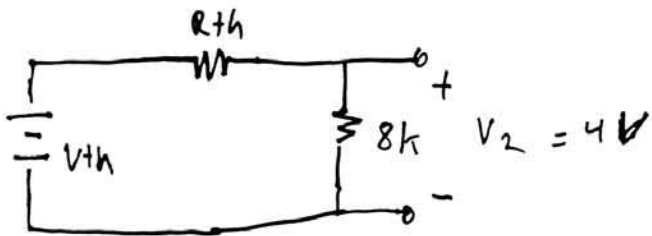

$$V_2 = 4 = V_{th} \left( \frac{8k}{8k + R_{th}} \right)$$

$$V_{th} \cdot 8k = 32k + 4R_{th}$$

$$V_{th} = \frac{R_{th}}{2k} + 4 \implies \text{Eqn. 2}$$

Solving eqn. 1 and eqn. 2,

$$\text{eqn. 1} - \text{eqn. 2} \Rightarrow$$

$$\frac{R_{th}}{2k} - 3 = 0$$

$$R_{th} = 6k \Omega$$

Using eqn. 1,

$$V_{th} = \frac{R_{th}}{1k} + 1 = \frac{6k}{1k} + 1 = 7.0V$$

$$b.) \quad V_{th} = V_1 \left( \frac{R_2}{R_1 + R_2} \right) = 20 \left( \frac{3k}{1k + 3k} \right) = 15 \text{ V}$$

$$R_{th} = 3k \parallel 1k = \frac{3k \cdot 1k}{3k + 1k} = 750 \Omega$$

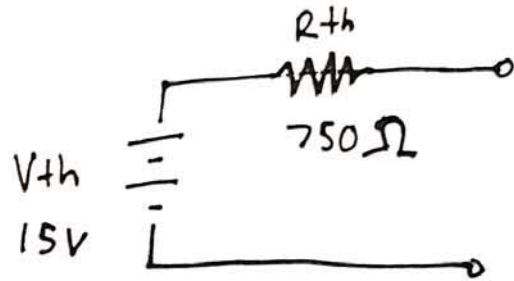

c.) Using our result from part b,

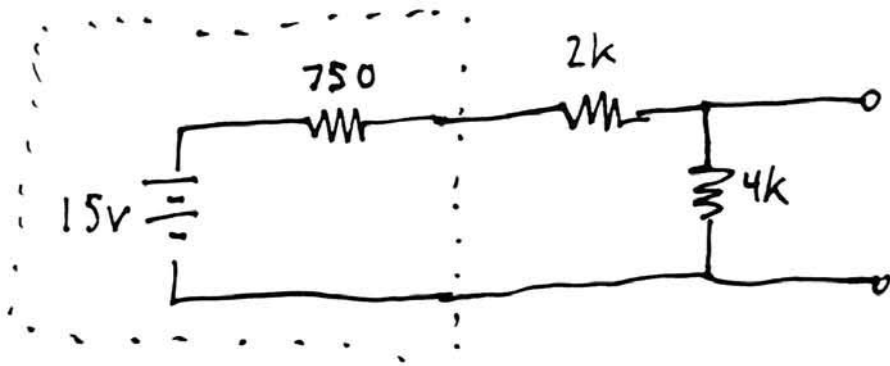

$$V_{th} = 15 \left( \frac{4k}{750 + 2k + 4k} \right) = 8.89 \text{ V}$$

$$R_{th} = (2k + 750) \parallel 4k = \frac{(2750)(4000)}{2750 + 4000} = 1630 \Omega$$

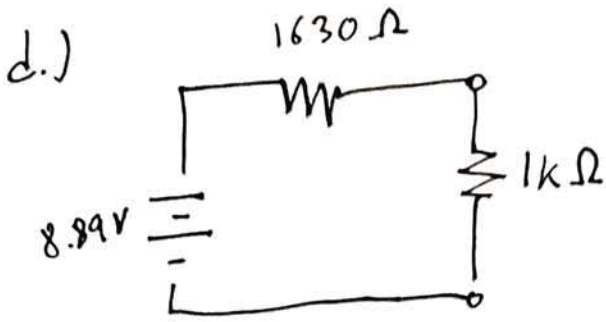

$$I_{load} = \frac{8.89V}{(1630 + 1000)\Omega} = 3.38 \text{ mA}$$

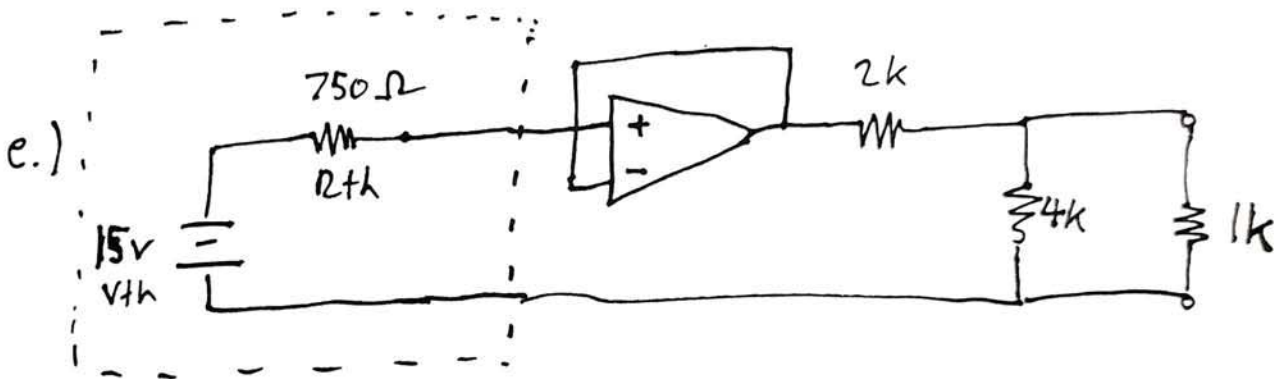

Since the voltage follower draws no current at its inputs, it will have an input voltage of  $V_{th} = 15V$ . Its output voltage will also be  $15V$ . We can now represent the circuit as:

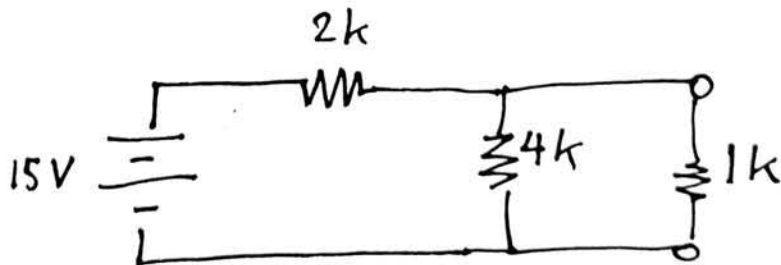

$$4k \parallel 1k = \frac{4k \cdot 1k}{4k + 1k} = 800 \Omega$$

$$V_{load} = 15 \cdot \frac{800}{800 + 2k} = 4.29 \text{ V}$$

$$I_{load} = \frac{4.29V}{1k\Omega} = 4.29 \text{ mA}$$

II.

a.)

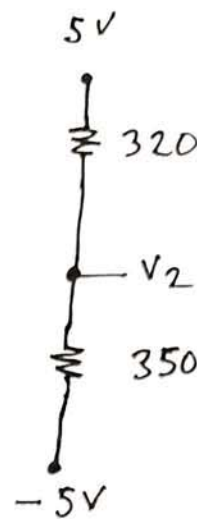
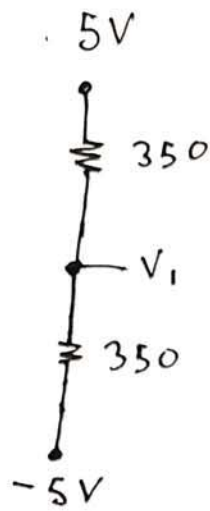

$$V_1 = -5V + (5 - (-5)) \frac{350}{350 + 350} = 0V$$

$$V_2 = -5V + (5 - (-5)) \frac{350}{320 + 350} = 0.22V$$

b.) 
$$V_{out} = \frac{R_8}{R_6} (V_2 - V_1) = \frac{R_7}{R_5} (V_2 - V_1)$$

$$V_1 = 0V$$

$$800mV = \frac{10k}{1k} (0 - V_1)$$

$$V_1 = -80mV = [(5 - (-5))] \frac{R_4}{R_3 + R_4} - 5$$

$$V_1 = 10 \frac{500}{R_3 + 500} - 5 = -80mV$$

$$R_3 = 516.3 \Omega$$

c.) Suppose that  $R_3$  is  $450 \Omega$ .

$$V_1 = 0V$$

$$V_2 = -5V + 10 \frac{500}{450 + 500} = 0.26V$$

$$V_{out} = \frac{R_8}{R_6} (0 - 0.26V) = \frac{R_7}{R_5} (0 - 0.26V)$$

$V_{out}$  will saturate at  $-5V$ . Therefore,

$$-5 = \frac{R_8}{R_6} (-0.26V)$$

$$\frac{R_8}{R_6} = \frac{R_7}{R_5} = 19.23$$

$$R_5 = R_6 = 1k\Omega$$

so

$$R_8 = R_7 = 19.23k\Omega$$

We can find the same answer by setting  $R_3$  to  $550 \Omega$ .

d.) Various physical factors, including beam and strain gauge deformation and small variations in resistor values, will cause each cantilever beam to produce a different output voltage when attached to the diff amp circuit at zero deflection. Changing beams mid-experiment would introduce measurement error.

e.) With two strain gauges, one will be subjected to tension while the other experiences compression and vice versa, and one resistance will decrease while the other increases and vice versa. This doubles the voltage response of the system for a given amount of deflection.

f.) The small positive voltage means that the value of  $R_3$  is larger than  $500\ \Omega$ . We could re-zero the circuit by adding a small resistor in series with  $R_4$  or  $R_1$ , or a large resistor in parallel with  $R_3$ .

III. Operational Amplifier Applications (20 points)

B

a. {3 pts} What type of amplifier is each circuit?

|   |                                     |   |                          |
|---|-------------------------------------|---|--------------------------|
| A | <i>differentiator</i>               | B | <i>non inverting Amp</i> |
| C | <i>summer (or) Inverting summer</i> | D | <i>Difference Amp</i>    |
| E | <i>Integrator</i>                   | F | <i>inverting amp</i>     |

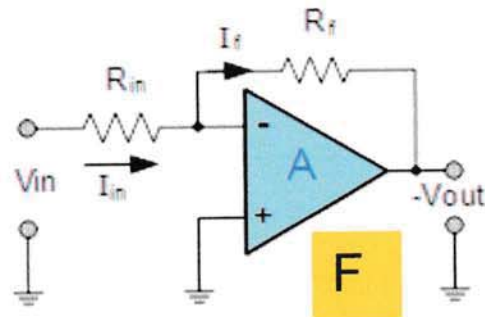
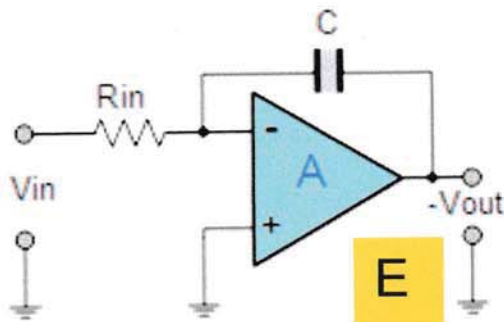
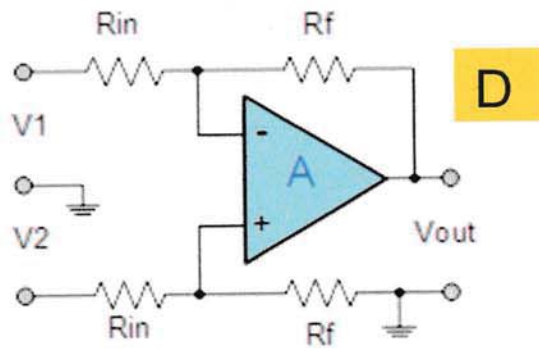
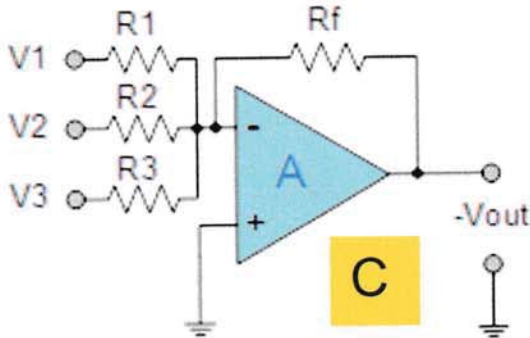
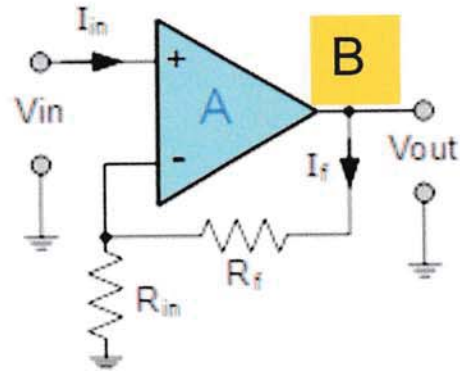
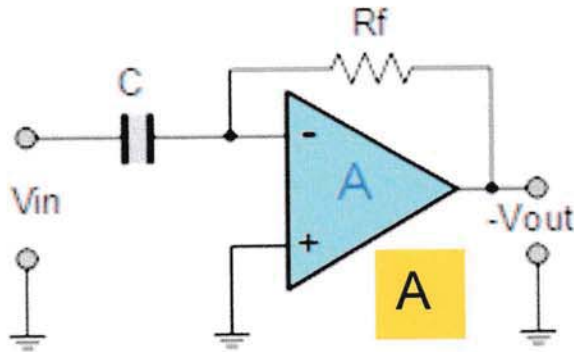



- b. (6 pts) Design a non-inverting amplifier circuit with a **gain of 20**, specify resistor values, **the resistors must have values of  $\geq 1k\Omega$** . Draw the circuit schematic. Be sure to label **the input and the output**. You can assume any resistor value is available. (6 pts)

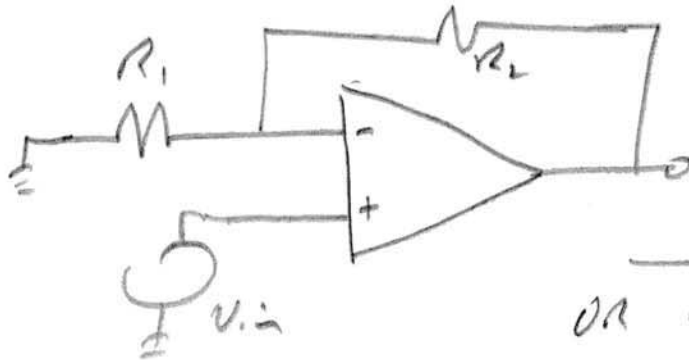

Value such that  
 $1 + \frac{R_2}{R_1} = 20 \Rightarrow \frac{R_2}{R_1} = 19$   
 Example let  $R_1 = 1k$   
 $R_2 = 19k$

OR  $R_1 = 2k, R_2 = 38k$

OR  $R_2 = 20k, R_1 = 1.05k$

- c. (6 pts) Using the ideal op amp rules, "Op Amp Analysis Rules", determine for each circuit below the values for  $V_+$ ,  $V_-$ , and  $I_{in}$ . These circuits aren't connected to each other in any way. As with all problems, include units.

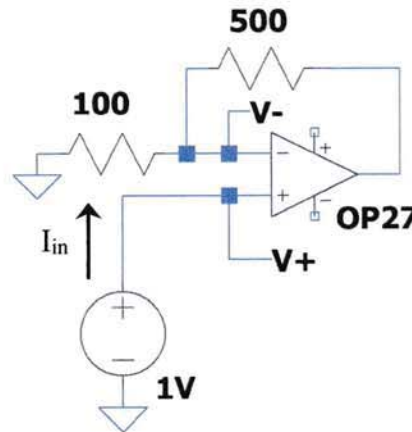
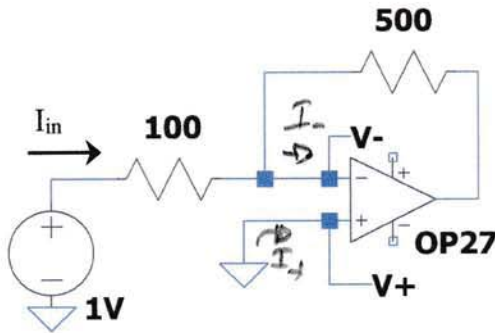

Ideal Op Amp  $V_+ = V_-$   
 $I_- = 0, I_+ = 0$

Left Circuit:

$V_+ = 0V$

$V_- = 0V$

$I_{in} = \frac{(V_{in} - V_-)}{100}$   
 $= \frac{1}{100} = 0.01 A$   
 OR  $10mA$

Right Circuit:

$V_+ = V_{in} = 1V$

$V_- = V_+ = 1V$

$I_{in} = I_+ = 0$

Solu

d) (5 pts) For the circuit shown on the right:

i) (1pt) For what range of frequencies will this behave as an integrator? Provide the answer in Hertz.

$\omega \gg \frac{1}{R_f C}$        $\frac{1}{R_f C} = 10^3 \text{ radians/sec}$   
 $f \gg \frac{1}{2\pi R_f C}$        $f \gg 159 \text{ Hz}$

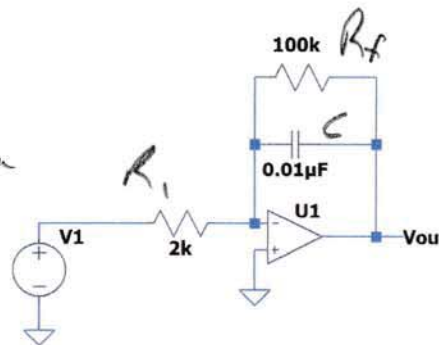

ii) (1pt) Will it be a reasonable intergrator if V1 is a sinewave at 2kHz?

~~2kHz~~ 2kHz is  $\gg$  than 159 Hz, **Yes**

iii) (3pt) For this part assume it is a good integrator. If V1 is a sinewave with an amplitude of 0.5V and a frequency of 2kHz and a phase angle at t=0 or 0 degrees, what is Vout in the form of  $V_{out} = V_{amp} \sin(\omega t + \theta)$ . In other words: Give  $V_{amp}$ ,  $\omega$ , and  $\theta$  of the output.

$\omega = 2\pi f = 12,600$

$|H(j\omega)| = \frac{-1}{j\omega R_f C} = \frac{-1}{(j)(12,600)(2000) 10^{-8}}$

$|H(j\omega)| = \frac{1}{(12600)(2000) 10^{-8}} = \boxed{4}$        $|V_{out}| = |V_{in}| \cdot \boxed{4}$

$\angle H(j\omega) = \frac{-1}{j} = j \Rightarrow 90^\circ \text{ or } \pi/2$        $|V_{out}| = \boxed{2}$

~~$V_{out}(t) =$~~   $V_{amp} = \boxed{2V}$

$\omega = 12,600$

$\theta = 90^\circ \text{ or } \pi/2 \text{ radians}$

**IV – Concepts, Troubleshooting and Data Analysis (20 points)**

a. (7 pts) Real components compared to ideal: In Experiment 5 you built and modeled the circuit on the right.

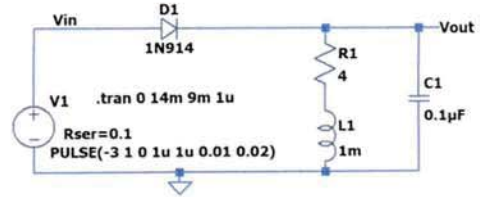

i. For the LTspice model you included R1. But you didn't put a resistor there when you built the circuit. Why not? {1pt}

*R1 is the resistance of the coil. It is part of the*

*OR R1 is part of the coil model.*

ii. Energy is lost as a function of time in the harmonic oscillator circuit as Vout was oscillating. Which component in the circuit shown in part i. of this problem causes the energy loss? {1pt}

*Either say R1 or the coil. It is the coil resistance that causes the energy loss. (The effective resistance of the cap is very small)*

iii. Continuing with the energy loss question, will the energy loss be most rapid when the current in the inductor is at the maximum, or at 0A or energy loss doesn't depend on which part of the oscillation? Circle one. {2pts}

peak energy loss at:

I<sub>L</sub> is at a peak    I<sub>L</sub>=0    doesn't depend on which part of an oscillation (circle one)

iv. The inductor used for this circuit was a 1mH inductor. If by mistake your partner used a 10mH inductor, would the resonant frequency go up or down, and by what percentage would the frequency change, to the nearest 1%? {3pts}

$$\omega_0 \approx \frac{1}{\sqrt{LC}}$$

$$\omega_{error} = \frac{1}{\sqrt{10LC}} = \left(\frac{1}{\sqrt{10}}\right) \left(\frac{1}{\sqrt{LC}}\right) = \frac{1}{\sqrt{10}} \omega_0$$

$$\omega_{error} = 0.316 \omega_0$$

*Drop by 68.4% ⇒ 68%*

Soln

750mV at 0.2 sec

Pick any 2 points, Must subtract Vavg

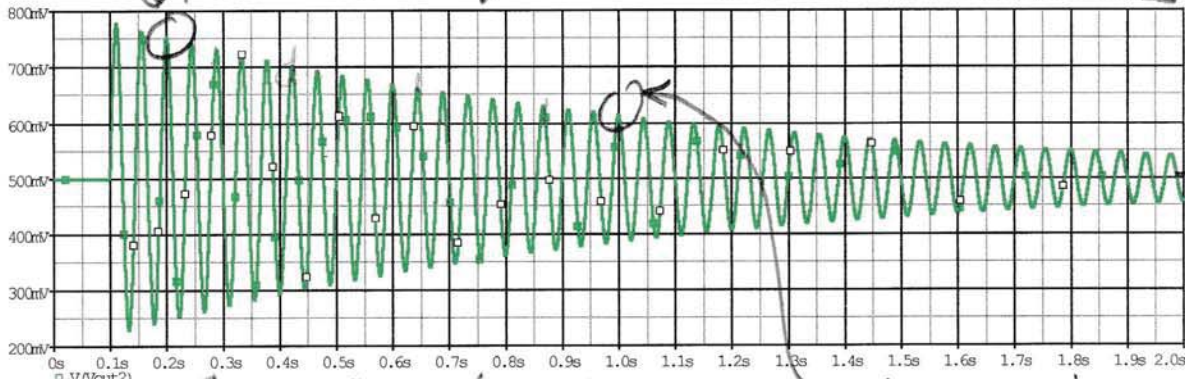

17 18 cycles → Time 610mV at 1sec

- b. (4 pts) The plot shown above represents data taken from the accelerometer on a beam after it has been integrated by an op-amp circuit. Note that there is a dc offset, typical of integration. Find the decay constant  $\alpha$  and the angular frequency  $\omega$  for this data. **You must mark the data points on the plot that you use for your answer.**

at 0.2 sec  $V_{amp} = 750 - 500 = 250 \text{ mV} = V_1$   
 at 1.0 sec  $V_{avg} = 610 - 500 = 110 \text{ mV} = V_2$

18 cycles in 0.8 sec  
 $f = 22.5 \text{ Hz}$   
 $\omega = 90 \text{ rad/sec}$

$$\frac{V(t_2)}{V(t_1)} = \frac{110}{250} = e^{-\alpha(t_2 - t_1)} = e^{-\alpha(0.8)}$$

$$\ln \frac{110}{250} = (-\alpha)(0.8)$$

$$\alpha = 1.03 \approx 1 \text{ sec}^{-1}$$

- c. (4 pts) Classroom Knowledge and Tasks: **True or False, circle one.**

i. Before beginning a lab, at least one team member must read over and be generally acquainted with the experiment or project write-up and the other **required reading** materials listed on the EILinks page.

**True or False**

ii. The velocity of the beam can be measured by using a differentiator op amp circuit with the accelerometer.

**True or False**

iii. When asking for a signature on a check off page you show the instructor a live simulation or instrumentation board measurement. Live refers to it running on your computer at the time of the check off.

**True or False**

iv. You don't need to have done hand-drawn schematics for the first checkoff of an experiment.

**True or False**

$V_s = \pm 15V, T_A = 25^\circ C$ , unless otherwise noted

Table 1.

| Parameter                                       | Symbol        | Test Conditions                     | OP27A/OP27E |            |            | OP27G      |     |                 | Unit |
|---|---------------|-------------------------------------|-------------|------------|------------|------------|-----|-----------------|------|
|   |               |                                     | Min         | Typ        | Max        | Min        | Typ | Max             |      |
| INPUT OFFSET VOLTAGE <sup>1</sup>               | $V_{OS}$      |                                     | 10          | 25         | 30         | 100        |     | $\mu V$         |      |
| LONG-TERM $V_{OS}$ STABILITY <sup>2,3</sup>     | $V_{OS}/Time$ |                                     | 0.2         | 1.0        | 0.4        | 2.0        |     | $\mu V/Mo$      |      |
| INPUT OFFSET CURRENT                            | $I_{OS}$      |                                     | 7           | 35         | 12         | 75         |     | nA              |      |
| INPUT BIAS CURRENT                              | $I_B$         |                                     | $\pm 10$    | $\pm 40$   | $\pm 15$   | $\pm 80$   |     | nA              |      |
| INPUT NOISE VOLTAGE <sup>4</sup>                | $e_{n,pp}$    | 0.1 Hz to 10 Hz                     | 0.08        | 0.18       | 0.09       | 0.25       |     | nV p-p          |      |
| INPUT NOISE Voltage Density <sup>1</sup>        | $e_n$         | $f_0 = 10$ Hz                       | 3.5         | 5.5        | 3.8        | 8.0        |     | nV/ $\sqrt{Hz}$ |      |
|   |               | $f_0 = 30$ Hz                       | 3.1         | 4.5        | 3.3        | 5.6        |     | nV/ $\sqrt{Hz}$ |      |
|   |               | $f_0 = 1000$ Hz                     | 3.0         | 3.8        | 3.2        | 4.5        |     | nV/ $\sqrt{Hz}$ |      |
| INPUT NOISE Current Density <sup>1</sup>        | $i_n$         | $f_0 = 10$ Hz                       | 1.7         | 4.0        | 1.7        |            |     | pA/ $\sqrt{Hz}$ |      |
|   |               | $f_0 = 30$ Hz                       | 1.0         | 2.3        | 1.0        |            |     | pA/ $\sqrt{Hz}$ |      |
|   |               | $f_0 = 1000$ Hz                     | 0.4         | 0.6        | 0.4        |            |     | pA/ $\sqrt{Hz}$ |      |
| INPUT RESISTANCE Differential Mode <sup>5</sup> | $R_{IN}$      |                                     | 1.3         | 6          | 0.7        | 4          |     | M $\Omega$      |      |
|   | $R_{INCM}$    |                                     |             | 3          |            | 2          |     | G $\Omega$      |      |
| INPUT VOLTAGE RANGE                             | $I_{VR}$      |                                     | $\pm 11.0$  | $\pm 12.3$ | $\pm 11.0$ | $\pm 12.3$ |     | V               |      |
| COMMON-MODE REJECTION RATIO                     | $CMRR$        | $V_{CM} = \pm 11V$                  | 114         | 126        | 100        | 120        |     | dB              |      |
| POWER SUPPLY REJECTION RATIO                    | $PSRR$        | $V_s = \pm 4V$ to $\pm 18V$         | 1           | 10         | 2          | 20         |     | $\mu V/V$       |      |
| LARGE SIGNAL VOLTAGE GAIN                       | $A_{VOL}$     | $R_L \geq 2k\Omega, V_O = \pm 10V$  | 1000        | 1800       | 700        | 1500       |     | V/mV            |      |
|   |               | $R_L \geq 600\Omega, V_O = \pm 10V$ | 800         | 1500       | 600        | 1500       |     | V/mV            |      |
| OUTPUT VOLTAGE SWING                            | $V_O$         | $R_L \geq 2k\Omega$                 | $\pm 12.0$  | $\pm 13.8$ | $\pm 11.5$ | $\pm 13.5$ |     | V               |      |
|   |               | $R_L \geq 600\Omega$                | $\pm 10.0$  | $\pm 11.5$ | $\pm 10.0$ | $\pm 11.5$ |     | V               |      |
| SLEW RATE <sup>6</sup>                          | $SR$          | $R_L \geq 2k\Omega$                 | 1.7         | 2.8        | 1.7        | 2.8        |     | V/ $\mu s$      |      |
| GAIN BANDWIDTH PRODUCT <sup>7</sup>             | $GBW$         |                                     | 5.0         | 8.0        | 5.0        | 8.0        |     | MHz             |      |
| OPEN-LOOP OUTPUT RESISTANCE                     | $R_O$         | $V_O = 0, I_O = 0$                  |             | 70         |            | 70         |     | $\Omega$        |      |
| POWER CONSUMPTION                               | $P_d$         | $V_O$                               |             | 90         | 140        | 100        | 170 | mW              |      |
| OFFSET ADJUSTMENT RANGE                         |               | $R_O = 10k\Omega$                   |             | $\pm 4.0$  |            | $\pm 4.0$  |     | mV              |      |

$R_L > 2k$   
 $R_L < 2k$  but  $\geq 600\Omega$

d. (5 pts) Part of the data sheet for the OP27 is shown. Use this to answer the following questions. Look at typical values for the G version, OP27G.

i. If the OP27G is powered by  $\pm 15V$  supplies and has a  $10k\Omega$  load, what are the expected maximum and minimum output voltages you can expect to achieve? (1pt)

$R_L > 2k\Omega$  so  $\pm 13.5V$

ii. If the load is changed to  $600\Omega$ , what is the expected max and min output voltages? (1pt)

$R_L < 2k$  so use  $600\Omega$  values  $\pm 11.5V$

iii. For the ideal op amp model what are the value of  $I_+$  and  $V_+$  as shown in the figure on the right?(1pt)

$V_+ = 0, I_+ = 0$

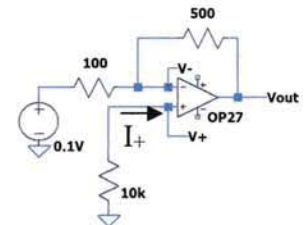

iv. The data sheet lists the actual expected values of  $I_+$  as something called INPUT BIAS CURRENT. Using the largest typical value of the INPUT BIAS CURRENT, what would be the value of  $V_+$  for this circuit? (2pt)

typical  $I_{Bias} = \pm 15nA$ , us  $15nA$   $15nA$  through  $10k$

$= -15nA \times 10^4$   
 $= -0.15mV$

v. (2pt) Extra credit: Given your answer above, what would be the error in  $V_{out}$  due to the INPUT Bias Current?

$-0.15mV$  at  $V_+$   $\Rightarrow$  gain of non-inverting amp is 6  
 $V_{out}(I_{bias}) = (6)(-0.15mV) = -0.9mV$